

SIEMENS

Reyrolle 7SR10 Operating

V01.00

Manual

Preface

Table of Contents

First Steps

1

Installing the Device

2

Handling of the Device

3

Using the Device Fascia

4

Using Reydisp Software

5

In Service Operation

6

Commissioning

7

Device Maintenance

8

Security Settings

9

Firmware and Hardware Revision History

A

Index

**NOTE**

For your own safety, observe the warnings and safety instructions contained in this document, if available.

Disclaimer of Liability

Subject to changes and errors. The information given in this document only contains general descriptions and/or performance features which may not always specifically reflect those described, or which may undergo modification in the course of further development of the products. The requested performance features are binding only when they are expressly agreed upon in the concluded contract.

Document version: C53000-B7040-C002-5.01

Edition: 06.2024

Version of the product described: V01.00

Copyright

Copyright © Siemens 2024. All rights reserved.

The disclosure, duplication, distribution and editing of this document, or utilization and communication of the content are not permitted, unless authorized in writing. All rights, including rights created by patent grant or registration of a utility model or a design, are reserved.

SIPROTEC, DIGSI, SIGRA, SIGUARD, SIMEAS, SICAM, Insights Hub, and OT Companion are trademarks of Siemens. Any unauthorized use is prohibited.

Preface

Purpose of the Manual

This manual describes the operation of the device and gives information about safety, commissioning, and operation as well as checks and tests.

Target Audience

This manual is mainly intended for protection system engineers, commissioning engineers, persons entrusted with the setting, testing and maintenance of automation, selective protection and control equipment, and operational crew in electrical installations and power plants.

Scope

This manual applies to the Reyrolle device family.

Further Documentation

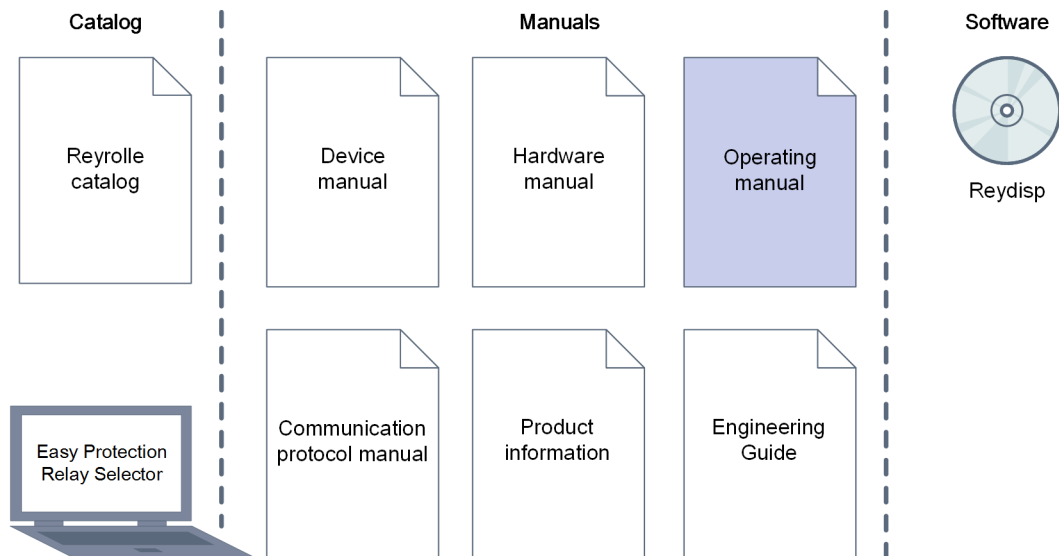

[dw_reyrolle-catalog_furtherdocumentation_operatingmanual, 1, en_US]

- **Device manual**
The device manual describes the functions and applications of a Reyrolle device. The printed manual for the device has the same informational structure.
- **Hardware manual**
The hardware manual describes the hardware building blocks and device combinations of the Reyrolle device family.
- **Operating manual**
The operating manual describes the basic principles and procedures for operating and installing the devices of the Reyrolle device family.

- **Communication protocol manual**
The communication protocol manual contains a description of the protocols for communication within the Reyrolle device family and to higher-level network control centers.
- **Product information**
The product information includes general information about device installation, technical data, limiting values for input and output modules, and conditions when preparing for operation. This document is provided with each Reyrolle device.
- **Engineering Guide**
The engineering guide describes the essential steps when engineering with Reydisp. In addition, the engineering guide shows you how to load a planned configuration to a Reyrolle device and update the functionality of the Reyrolle device.
- **Reyrolle catalog**
The Reyrolle catalog describes the Reyrolle devices and the system features.
- **Easy Protection Relay Selector for Reyrolle and SIPROTEC**
This tool gives a quick guidance to find a protection relay of SIPROTEC 5, SIPROTEC 4, SIPROTEC Compact, Reyrolle which would fit your needs.

Additional Support

For questions about the system, contact your Siemens sales partner.

Customer Support Center

Our Customer Support Center provides a 24-hour service.

Siemens Electrification & Automation

Global Support

Single entry point

Phone: +49 9131 1743072

E-mail: support.ea.siemens.com

Training Courses

You can request the individual training course offer at our Training Center:

Siemens AG

Siemens Power Academy TD

Humboldtstraße 59

90459 Nuremberg

Germany

Phone: +49 911 9582 7100

E-mail: poweracademy@siemens.com

Internet: www.siemens.com/poweracademy

Notes on Safety

This document is not a complete index of all safety measures required for operation of the equipment (module or device). However, it comprises important information that must be followed for personal safety, as well as to avoid material damage. Information is highlighted and illustrated as follows according to the degree of danger:



DANGER

DANGER means that death or severe injury **will** result if the measures specified are not taken.

- ✧ Comply with all instructions, in order to avoid death or severe injuries.
-



WARNING

WARNING means that death or severe injury **may** result if the measures specified are not taken.

- ✧ Comply with all instructions, in order to avoid death or severe injuries.
-



CAUTION

CAUTION means that medium-severe or slight injuries **can** occur if the specified measures are not taken.

- ✧ Comply with all instructions, in order to avoid moderate or minor injuries.
-

NOTICE

NOTICE means that property damage **can** result if the measures specified are not taken.

- ✧ Comply with all instructions, in order to avoid property damage.
-



NOTE

Important information about the product, product handling or a certain section of the documentation which must be given attention.

OpenSSL

This product includes software developed by the OpenSSL Project for use in OpenSSL Toolkit (<http://www.openssl.org/>).

This product includes software written by Tim Hudson (tjh@cryptsoft.com).

This product includes cryptographic software written by Eric Young (eay@cryptsoft.com).

Table of Contents

	Preface	3
1	First Steps	11
	1.1 Unpacking, Repacking, Returning, and Storing.....	12
	1.2 Environmental Protection Hints.....	13
	1.3 Incoming Inspection	14
	1.4 Electrical Inspection	15
2	Installing the Device	17
	2.1 Drilling Patterns and Device Dimensions.....	18
	2.2 Mounting Instructions.....	19
	2.3 Installing Devices.....	20
	2.4 Grounding and Connecting Devices	21
	2.5 Recommended Terminal-Lugs Specifications.....	22
3	Handling of the Device	25
	3.1 Directional and Non-Directional Relay Views	26
	3.2 Front-Cover Mounting Instructions.....	28
	3.3 Surface-Mounting Bracket Installation Instructions.....	31
	3.4 Replacement of the Device	35
4	Using the Device Fascia	37
	4.1 General.....	38
	4.2 Overview of Operator Elements and Display Elements.....	39
	4.3 Structure of the Menu.....	43
	4.3.1 Relay Menu	43
	4.3.2 User-Interface Operation	44
	4.3.3 Setting Mode	45
	4.3.4 Instrument Mode	45
	4.3.5 Fault Data Mode	54
	4.3.6 Menu Tree.....	55
	4.3.6.1 7SR10 Menu Navigation Tree.....	55
5	Using Reydisp Software	57
	5.1 Reydisp Evolution Software.....	58
	5.2 Reydisp Manager Software.....	59
6	In Service Operation	61
	6.1 Overview.....	62
	6.2 Safety Notes.....	63

6.3	Operation Options.....	64
6.3.1	General.....	64
6.4	Indications.....	65
6.4.1	General.....	65
6.4.2	Displaying Indications.....	65
6.5	Reading Fault Data from the Relay LCD.....	66
6.6	Reading Fault Event Data and Waveform Records from Reydisp Evolution.....	67
6.7	Logs.....	69
6.7.1	Data Storage.....	69
6.8	Metering.....	73
6.9	Operating Mode.....	74
6.10	Control Mode.....	75
6.11	Real-Time Clock (RTC).....	76
6.12	Change Device Settings.....	77
6.13	Settings Group	79
6.14	User-Specific Curves	80
7	Commissioning.....	81
7.1	Overview.....	82
7.2	Test Suite Integrated in the Device.....	84
7.2.1	Testing Protection Functions.....	84
7.2.2	Initial Startup.....	84
7.2.3	Precommissioning Tests.....	85
8	Device Maintenance.....	87
8.1	Self-Monitoring	88
8.2	Protection Healthy/Defective.....	90
8.3	Circuit-Breaker Maintenance.....	91
8.3.1	CB Counters	91
8.3.2	I ² t CB Wear.....	91
8.4	Periodic Maintenance.....	92
8.5	Troubleshooting.....	93
8.6	Replace and Return Defective Device.....	95
8.6.1	Error Backup Device	95
8.6.2	Replacing a Device	95
8.6.3	Returning a Device.....	95
8.7	Firmware Upgrade and Loading.....	96
8.7.1	Guidelines.....	96
8.7.2	Firmware Upgrade in Relay Installed On-site.....	96
8.7.3	Firmware Loading in New Relay.....	100
8.7.4	Firmware Loading in Old Relays.....	102
9	Security Settings.....	105
9.1	Confirmation ID (Password Feature).....	106
A	Firmware and Hardware Revision History.....	107
A.1	Revision History.....	108

Index..... 109

1 First Steps

1.1	Unpacking, Repacking, Returning, and Storing	12
1.2	Environmental Protection Hints	13
1.3	Incoming Inspection	14
1.4	Electrical Inspection	15

1.1 Unpacking, Repacking, Returning, and Storing

Unpacking a Device



NOTE

Devices are tested before delivery. The test certificate is a component of the devices.
In this manual, the Reyrolle 7SR10 Argus overcurrent and earth-fault relay is referred to as 7SR10 relay.

- ✧ Check the packaging for external transport damage. Damaged packaging can indicate that the devices inside have also sustained damage.
- ✧ Unpack the devices carefully; do not use force.
- ✧ Check the devices via a reception control to ensure they are in perfect mechanical condition.
- ✧ Check the enclosed accessories against the delivery note to make sure that everything is complete.
- ✧ Keep the packaging, in case the devices must be stored or transported elsewhere.
- ✧ Return damaged devices to the manufacturer, stating the defect. Use the original packaging or transport packaging where possible.
- ✧ Check that the wiring terminal connectors are all included.
- ✧ Check that the mounting fixings are included.
- ✧ Check that the screws are included – one package per terminal block.

Repacking a Device

- ✧ If you store devices after the reception control, they must be packed in appropriate storage packaging.
- ✧ If the device is to be transported, pack it in transport packaging.
- ✧ Enclose the accessories supplied and the test certificate in the package with the device.

Returning a Device

- ✧ Return devices to the manufacturer, stating the defect. Use the original packaging or transport packaging where possible. Send damaged devices to the following address:
Siemens AG
SI EA O PA Repair/Return
Rohrdamm 7
13629 Berlin
Germany

Storing a Device

- ✧ Only store devices on which you have carried out an incoming inspection. This action ensures that the warranty remains valid. The incoming inspection is described in [1.3 Incoming Inspection](#).
- ✧ The 7SR10 relay must be stored in rooms, which are clean and dry. Devices must be stored at a temperature of -25 °C to +70 °C.
- ✧ The relative humidity must be at a level where condensed water and ice are prevented from forming.
- ✧ Siemens recommends observing a restricted storage temperature range of +10 °C to +35 °C, in order to prevent the electrolytic capacitors used in the power supply from aging prematurely.
- ✧ If the device has been in storage for more than 2 years, connect it to an auxiliary voltage for 1 to 2 days. This action causes the electrolytic capacitors to form on the printed circuit board assemblies again.
- ✧ If devices are to be shipped elsewhere, you can reuse the transport packaging. The storage packaging of the individual devices is not adequate for transport purposes.

1.2 Environmental Protection Hints

Disposal of Old Equipment and Batteries (Applicable only for European Union and Countries with a Recycling System)

The disposal of our products and possible recycling of their components after decommissioning has to be carried out by an accredited recycling company, or the products/components must be taken to applicable collection points. Such disposal activities must comply with all local laws, guidelines and environmental specifications of the country in which the disposal is done. For the European Union the sustainable disposal of electronic scrap is defined in the respective regulation for "waste electrical and electronic equipment" (WEEE).



The crossed-out wheellie bin on the products, packaging and/or accompanying documents means that used electrical and electronic products and batteries must not be mixed with normal household waste.

According to national legislation, penalties may be charged for incorrect disposal of such waste.

By disposing of these products correctly you will help to save valuable resources and prevent any potential negative effects on human health and the environment.



NOTE

Our products and batteries must not be disposed of as household waste. For disposing batteries it is necessary to observe the local national/international directives.

Disposal of Mobile Storage Devices (e.g. USB Sticks and Memory Cards)

When disposing of/transferring mobile storage devices, using the **format** or **delete** functions only changes the file management information and does not completely delete the data from your mobile storage device. When disposing of or transferring a mobile storage device, Siemens strongly recommends physically destroying it or completely deleting data from the mobile storage device by using a commercially available computer data erasing software.

REACH/RoHS Declaration

You can find our current **REACH/RoHS** declarations at:

<https://www.siemens.com/global/en/home/products/energy/ecotransparency/ecotransparency-downloads.html>



NOTE

You can find more information about activities and programs to protect the climate at the EcoTransparency website:

<https://www.siemens.com/global/en/home/products/energy/ecotransparency.html>

1.3 Incoming Inspection

Safety Notes



WARNING

Danger during incoming inspection

Non-compliance with the safety notes can result in death, severe injury, or considerable material damage.

- ◇ Comply with all given safety notes when carrying out the incoming inspection.
 - ◇ Note that hazardous voltages are present when you perform the incoming inspection.
-
- ◇ If you identify a defect during the incoming inspection, do not rectify it yourself. Repack the device and return it to the manufacturer, stating the defect. Use the original packaging or transport packaging where possible.

Performing a Follow-Up Inspection on a Device

- ◇ Visually check for external damage as soon as you have unpacked the devices; they must not show any signs of dents or cracks.

Checking the Rated Data and Functions

- ◇ Check the rated data and functions using the complete order designation/the product code. For a detailed description of the functions and for technical data, refer to the *7SR10 Device Manual* and to the *7SR10 Hardware Manual*.
- ◇ Check the information provided on the relay rating label too. The device features a product side label, which contains the technical data.
- ◇ Make sure that the rated data of the 7SR10 relay properly matches the system data. For more information, refer to the *7SR10 Device Manual*.

1.4 Electrical Inspection

Device Protection



DANGER

Danger when connecting the 7SR10 device.

Non-compliance with the safety notes will result in death, severe injury, or considerable material damage.

- ◇ The device must be situated in the operating area for at least 2 hours before you connect it to the power supply for the first time. This prevents condensation from forming in the device.
 - ◇ If the device has been in storage for more than 2 years, connect it to an auxiliary voltage for 1 to 2 days. This causes the electrolytic capacitors on the printed circuit-board assemblies to form again (applicable for auxiliary-powered variants only).
-
- ◇ Perform the inspection procedures and follow the safety measures.

Grounding a Device

The 7SR10 relays are protection class III equipment and must be connected with the system ground before commissioning.

- ◇ The ground cable must be wired using a non-stranded cable with a cross section of 2.5 mm²/4 mm². This ground cable must be terminated in the shortest possible path to the ground terminal/busbar in the panel or cubicle.
- ◇ In order to ensure the electromagnetic compatibility (EMC) of the device, connect the protective grounding terminals of the modules to each other in series connection. Use the double protective grounding terminals of the individual modules for this purpose.
- ◇ Connect the protective conductor of the protection device (connected modules) to the protective grounding terminal of the installation (for example control cabinet) with a single connection to the base module of the protection device.

Connecting a Device

- ◇ Connect all cables and wiring according to the terminal diagram. For more information on circuit diagrams, refer to the *7SR10 Device Manual* and *7SR10 Hardware Manual*.
- ◇ Tighten the terminal screws to the prescribed torques (refer to [2.5 Recommended Terminal-Lugs Specifications](#)).

Grounding an On-Site Operation Panel

- ◇ Join several on-site operation panels to one another with firm contact. Siemens recommends using contact washers on painted metal mounting walls. If the mounting wall is not metallic, then place a metal layer between the mounting wall and the on-site operation panels. Then connect the metal layer to the system grounding.

Safety Notes



DANGER

Danger during electrical inspection

Non-compliance with the safety notes will result in death, severe injury, or considerable material damage.

- ✧ Comply with all given safety notes when carrying out the electrical inspection.
 - ✧ Note that hazardous voltages are present when you perform the electrical inspection.
-
- ✧ During the electrical inspection, check that the device becomes ready for operation once it has been connected to the power supply.

Performing the Electrical Inspection

- ✧ Connect the power supply, where applicable for the devices ordered with auxiliary-supply option.
- ✧ Activate the power supply.
- ✧ If the device fails to power on, pack this device and return it to the manufacturer, stating the defect.

2 Installing the Device

2.1	Drilling Patterns and Device Dimensions	18
2.2	Mounting Instructions	19
2.3	Installing Devices	20
2.4	Grounding and Connecting Devices	21
2.5	Recommended Terminal-Lugs Specifications	22

2.1 Drilling Patterns and Device Dimensions

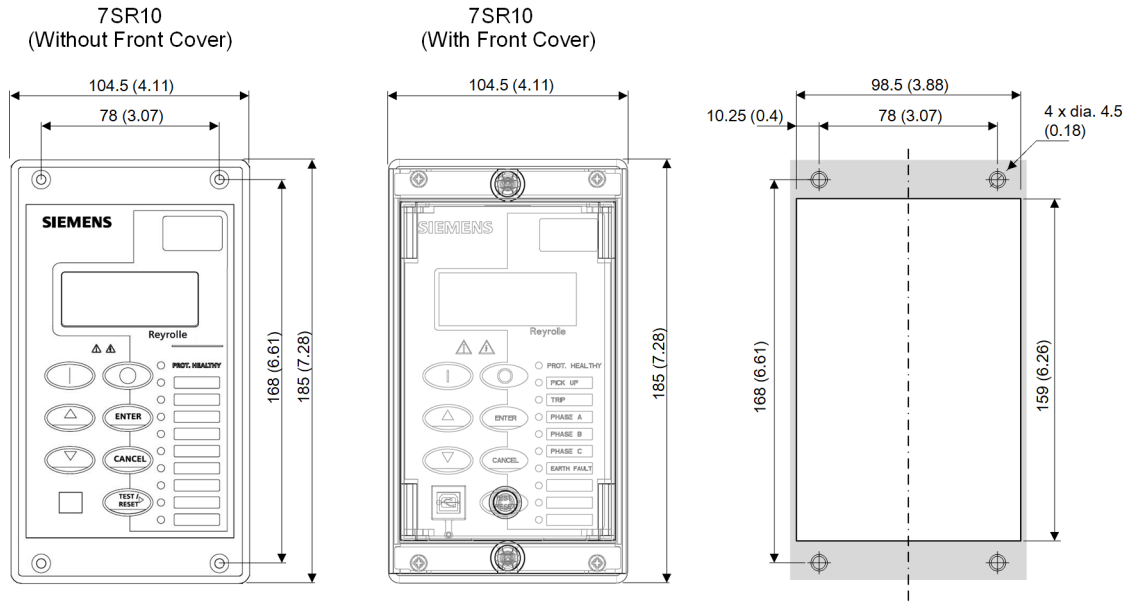

Dimensions in mm. Values in brackets in inches.

[dw_7SR10-casedimensions_2_en_US]

Figure 2-1 Front View, Panel Cut-out View

7SR10 (Without Front Cover)

7SR10 (With Front Cover)

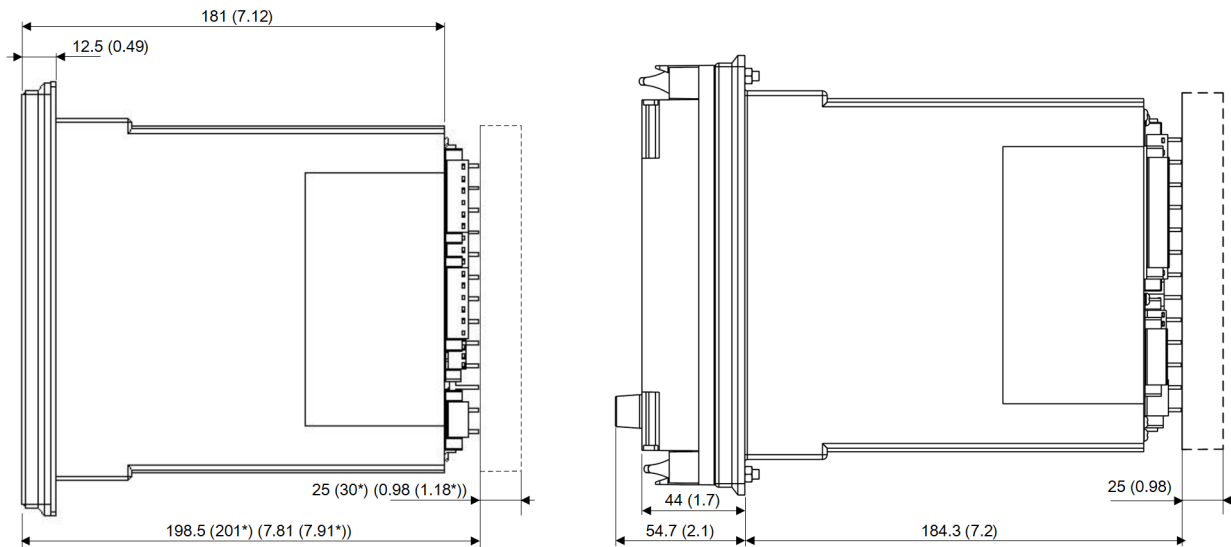

25 mm to 30 mm (0.98 inch to 1.18 inch)
clearance for terminal wiring

* Applicable for 7SR1003-1Mx20-2xx1

Dimensions in mm. Values in brackets in inches.

[dw_7SR10-sideview-dim_1_en_US]

Figure 2-2 Side View

2.2 Mounting Instructions

- ✧ The physical dimensions of the 7SR10 relay and the required cut-out dimensions are shown in [2.1 Drilling Patterns and Device Dimensions](#). To house the relay in the protection panel, create a slot of dimensions.
- ✧ Insert the rear-side of the relay into the ring-main unit (RMU) or protection-panel cut-out.
- ✧ Fasten the relay to the RMU/protection panel using 4 M4x20 Pan Phillips SS screws and nuts provided in the 7SR10 packing box with a torque of 0.5 Nm to 0.6 Nm.
- ✧ Carry-out all other installation steps and wiring connections from the protection panel.
- ✧ In the rear side of the relay, wire the device in accordance with the wiring diagrams as required. For more information on wiring details, refer to the *7SR10 Hardware Manual* and *7SR10 Device Manual*. For more information of recommended terminal lugs, refer to [2.5 Recommended Terminal-Lugs Specifications](#).
- ✧ Wire the ground cable using a non-stranded cable with a cross-section of 2.5 mm². Terminate the cable in the shortest possible path to the protective grounding terminal/busbar in the panel/cubicle.
- ✧ To ensure safety and prevent accidental touch of terminals, maintain a minimum clearance from the relay. For more details about the minimum clearance, refer to [2.1 Drilling Patterns and Device Dimensions](#). If the working area is restricted in a cubicle, then suitable protective terminals must be provided in the cubicle.



NOTE

The earth point (E) of the auxiliary supply is connected to the ground (GND) point of the relay. The ground (GND) point of the relay casing must be solidly connected to the panel ground.

2.3 Installing Devices

Preparations



NOTE

The installation depth for 1 device is at least 235 mm.
The M4 holes are the holes for the fastening screws of the device.



NOTE

Use a combi drive screwdriver.
For each device, you need 4 M4x20 Pan Phillips SS screws with nut.



DANGER

Danger due to the device being improperly screw-fastened

Incomplete and careless screw fitting results in death, severe injury, or considerable material damage!

- ✧ Ensure that fastening the screw is complete at all intended bolting points. Tighten the screws with the nuts using a torque of 0.5 Nm to 0.6 Nm.
-
- ✧ If no assembly opening is present, then create the cut-out slot required for the assembly opening.
 - ✧ Produce the holes as shown in the drilling plan.

Fitting Devices

- ✧ Detach the screws of each on-site operation panel.
- ✧ Insert the device in the installation opening. Make sure that the fastening screws of the on-site operation panels also protrude exactly into the openings.
- ✧ With the M4 screws, bolt the device at the top and bottom at all 4 bolting points of the device.
- ✧ Check for secure attachment.
- ✧ Fit the top and bottom screws again.

2.4 Grounding and Connecting Devices

Grounding the Devices



DANGER

Danger due to the device being improperly grounded.

Incomplete and careless grounding leads to death, severe injury, and considerable material damage!

- ✧ The device must be situated in the operating area for at least 2 hours before you connect it to the power supply for the first time. This prevents condensation from forming in the device.
 - ✧ If the device has been in storage for more than 2 years, connect it to an auxiliary voltage for 1 to 2 days. This causes the electrolytic capacitors to form on the printed circuit board assemblies.
-
- ✧ Wire the grounding cable using a non-stranded cable with a cross-section of 2.5 mm². Terminate the wire in the shortest possible path to the protective grounding terminal or busbar in the panel or cubicle.

Rear view

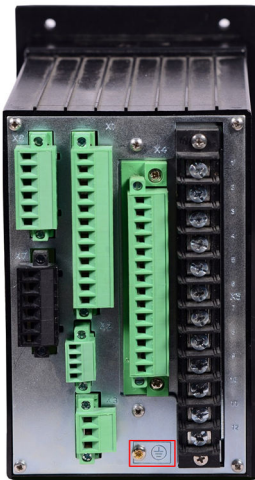

[sc_7SR10 directional_rear, 1, en_US]

Figure 2-3 Ground Point

Connecting Devices

- ✧ Connect all cables and leads. For more information on wiring diagrams, refer to the *7SR10 Hardware Manual* and *7SR10 Device Manual*.
- ✧ Tighten the terminal screws to the prescribed torques.

2.5 Recommended Terminal-Lugs Specifications

Table 2-1 Terminal Blocks (7SR10 Non-directional Overcurrent Relay)

Current inputs (X5)	Terminal connectivity PIDG series insulated tin plated crimp ring terminal, M3.5 stud size, 2.6 mm ² to 6.6 mm ² , 12 AWG; Torque required 1.0 Nm ± 10 %
Binary outputs (X4)	8 or 14 position, M3 screw-type plug-in terminals suitable for 2.5 mm ² cable; Torque required 0.5 Nm to 0.6 Nm
Binary inputs (X1)	6 or 12 position, M3 screw-type plug-in terminals suitable for 2.5 mm ² cable; Torque required 0.5 Nm to 0.6 Nm
Rear communication port (X2)	4 position, M2 screw-type plug-in terminals suitable for 1.5 mm ² cable; Torque required 0.34 Nm ± 10 %
Auxiliary supply (X3)	3 position, M3 screw-type plug-in terminals suitable for 2.5 mm ² cable; Torque required 0.5 Nm to 0.6 Nm
Ground terminal	Tin plated crimp ring terminal, M3 stud size, 4 mm ² to 6 mm ² , 12 AWG to 10 AWG, yellow; Torque required 0.5 Nm to 0.6 Nm
Front communication port	USB, type B

Table 2-2 Terminal Blocks (7SR10 Non-directional Overcurrent Relay [MLFB 7SR1003-1Mx20-2xx1])

Current inputs (X4)	Terminal connectivity PIDG series insulated tin plated crimp ring terminal, M3.5 stud size, 2.6 mm ² to 6.6 mm ² , 12 AWG; Torque required 1.0 Nm ± 10 %
Binary outputs (X3)	14 position, M2.5 screw-type plug-in terminals suitable for 2.5 mm ² cable; Torque required 0.5 Nm to 0.6 Nm
Binary inputs (X1)	18 position, M2.5 screw-type plug-in terminals suitable for 2.5 mm ² cable; Torque required 0.5 Nm to 0.6 Nm
Rear communication port and auxiliary power supply (X2)	9 position, M2.5 screw-type plug-in terminals suitable for 2.5 mm ² cable; Torque required 0.34 Nm ± 10 %
Ground terminal	Tin plated crimp ring terminal, M3 stud size, 4 mm ² to 6 mm ² , 12 AWG to 10 AWG, yellow; Torque required 0.5 Nm to 0.6 Nm
Front communication port	USB, type B

Table 2-3 Terminal Blocks (7SR10 Directional Overcurrent Relay)

Current inputs (X5)	Terminal connectivity PIDG series insulated tin plated crimp ring terminal, M3.5 stud size, 2.6 mm ² to 6.6 mm ² , 12 AWG; Torque required 1.0 Nm ± 10 %
Binary outputs (X4)	8 or 14 position, M3 screw-type plug-in terminals suitable for 2.5 mm ² cable; Torque required 0.5 Nm to 0.6 Nm
Binary inputs (X1)	6 or 12 position, M3 screw-type plug-in terminals suitable for 2.5 mm ² cable; Torque required 0.5 Nm to 0.6 Nm
Binary inputs (X6)	6 position, M3 screw-type plug-in terminals suitable for 2.5 mm ² cable; Torque required 0.5 Nm to 0.6 Nm

Rear communication port (X2)	4 position, M2 screw-type plug-in terminals suitable for 1.5 mm ² cable; Torque required 0.34 Nm ± 10 %
Auxiliary power supply (X3)	3 position, M3 screw-type plug-in terminals suitable for 2.5 mm ² cable; Torque required 0.5 Nm to 0.6 Nm
Voltage inputs (X7)	6 position, M3 screw-type plug-in terminals suitable for 2.5 mm ² cable; Torque required 0.57 Nm ± 10 %
Ground terminal	Tin plated crimp ring terminal, M3 stud size, 4 mm ² to 6 mm ² , 12 AWG to 10 AWG, yellow; Torque required 0.5 Nm to 0.6 Nm
Front communication port	USB, type B

3 Handling of the Device

3.1	Directional and Non-Directional Relay Views	26
3.2	Front-Cover Mounting Instructions	28
3.3	Surface-Mounting Bracket Installation Instructions	31
3.4	Replacement of the Device	35

3.1 Directional and Non-Directional Relay Views

The 7SR10 relay is housed in a non draw-out case 4U high, size 4.

The rear connection comprises user-friendly pluggable terminals for wiring connections to BI, BO, VT, communication, and power supply.

You can order the fascia cover with one push-button to allow you to reset the fault indication without removing the cover.

The current-transformer terminals (CT terminals) are suitable for ring-type lug connection to provide a secure and reliable termination.



[sc_7SR10 directional, 3, en_US]

Figure 3-1 7SR10 Directional Relay

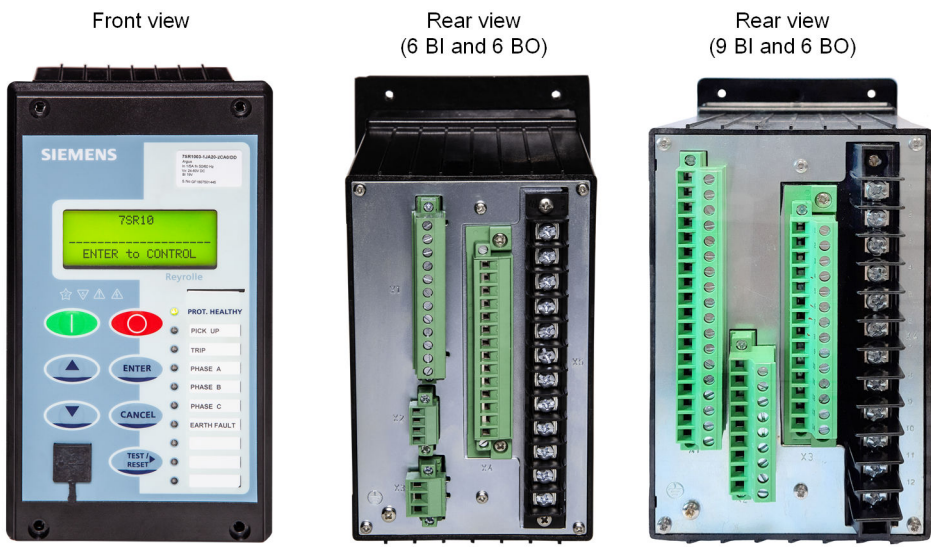

[sc_7SR10 non-directional, 3, en_US]

Figure 3-2 7SR10 Non-Directional Relay

Side label

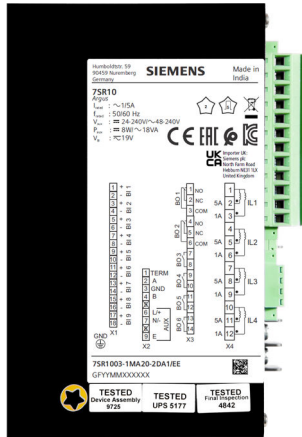

[sc 7SR10 side label, 6, en_US]

Figure 3-3 7SR10 Relay Side Label

3.2 Front-Cover Mounting Instructions

Accessory Variant	Description
7XG1900-0MA57-0FC0	Transparent front cover

Table 3-1 Fastener-Kit Specification for Front Cover

Fastener Kit Specifications	Quantity
Mounting bracket	2
M4x20 Pan Phillips stainless steel screw	4
Nut	4

✧ Fix the 7SR10 relay on the panel along with mounting brackets.

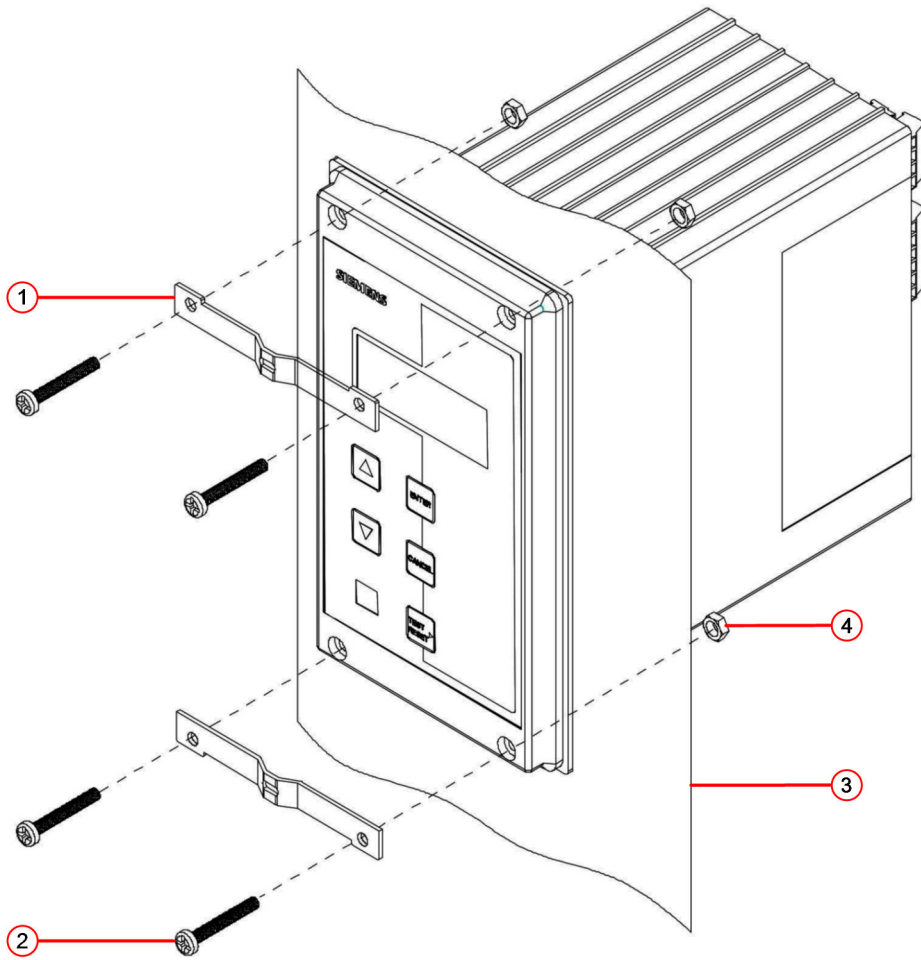

[dw_7SR10_frontcover_step1_1_en_US]

Figure 3-4 7SR10 Relay with Mounting Brackets

- (1) Mounting bracket
- (2) M4x20 Pan Phillips stainless steel screw (4 nos.)
- (3) Protection panel/cubicle
- (4) Nut (4 nos.)

✧ Assemble the removable fascia cover on the relay using the sealing knob.

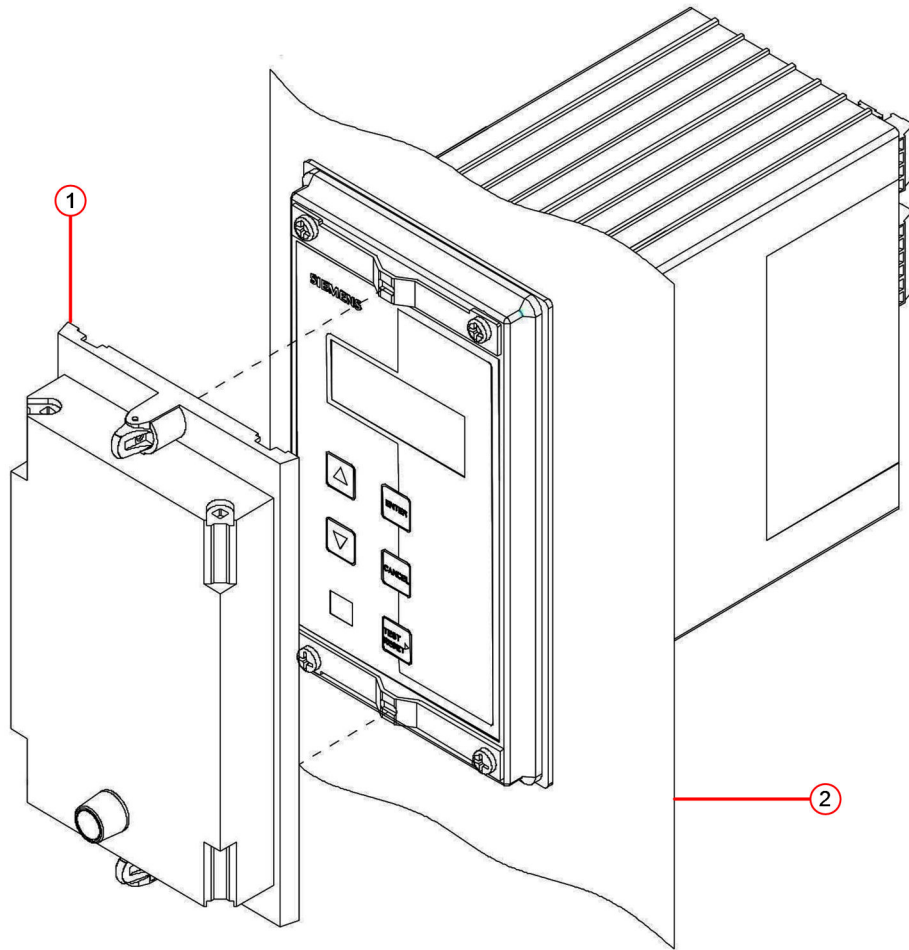

[dw_7SR10_frontcover_step2_1_en_US]

Figure 3-5 7SR10 Relay with Fascia Cover

- (1) Front cover
- (2) Protection panel/cubicle

✧ Lock the sealing knob by rotating in clockwise direction to lock.

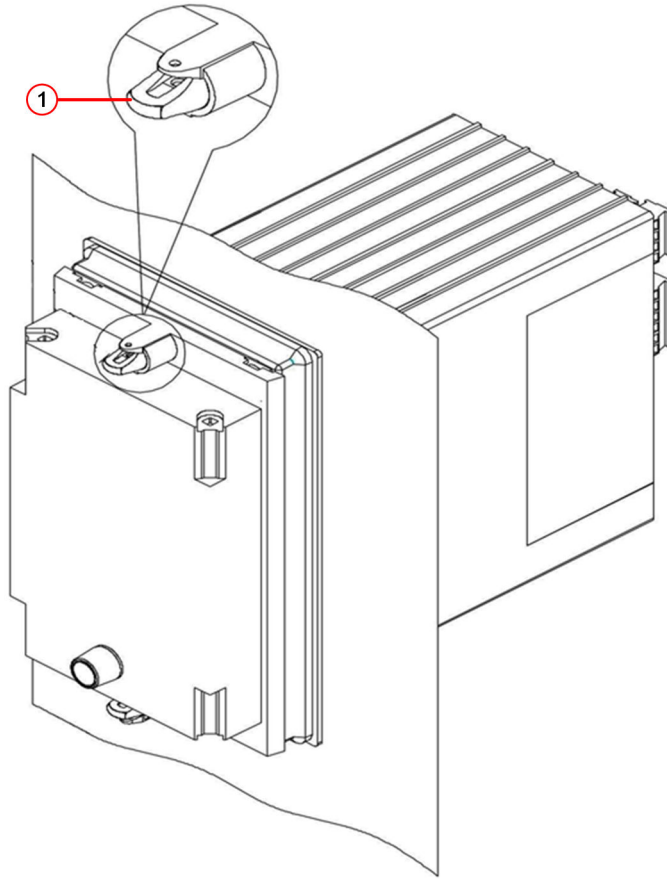

[dw_7SR10_frontcover_step3_1_en_US]

Figure 3-6 7SR10 Relay with Sealing Knob

- (1) Sealing knob

3.3 Surface-Mounting Bracket Installation Instructions

Accessory Variant	Description
7XG1900-0MA55-0FC0	Surface mounting bracket

Table 3-2 Fastener-Kit Specification for Surface-Mounting Bracket

Fastener Kit Specifications	Quantity
M6x16 mm stainless steel cross recessed pan head screw	4
M6 stainless steel flat washer	4
M6 stainless steel helical spring lock washer with flat end	4
M6 stainless steel hexagonal nut	4
M4x6 mm Phillips screw	1
M4 plain washer	1

- ✧ Fasten the surface mounting bracket to the RMU/protection panel using screw, flat washer, lock washer, and nut with a torque of 8.2 Nm.

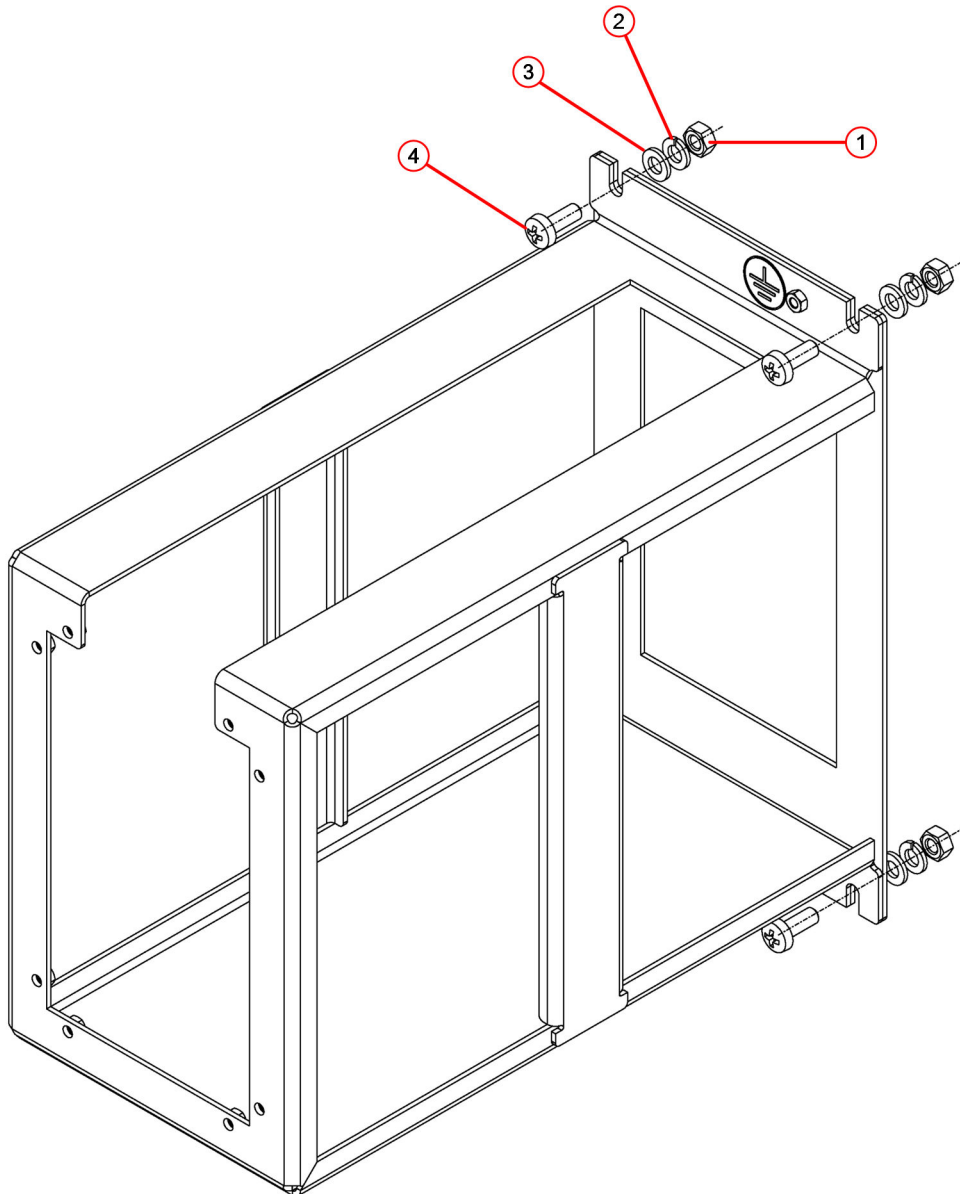

[dw_7SR10_surfacebracket_step1_1_en_US]

Figure 3-7 Fixing Surface Mounting Bracket to the RMU/Protection Panel

- (1) M6 stainless steel hexagonal nut (4 nos.)
 - (2) M6 stainless steel helical spring lock washer (4 nos.)
 - (3) M6 stainless steel flat washer (4 nos.)
 - (4) M6x16mm stainless steel cross recessed pan head screw
- ✧ Fix the 7SR10 relay to the surface mounting bracket using 4 M4x20 round SS studs with a torque of 1.0 Nm.

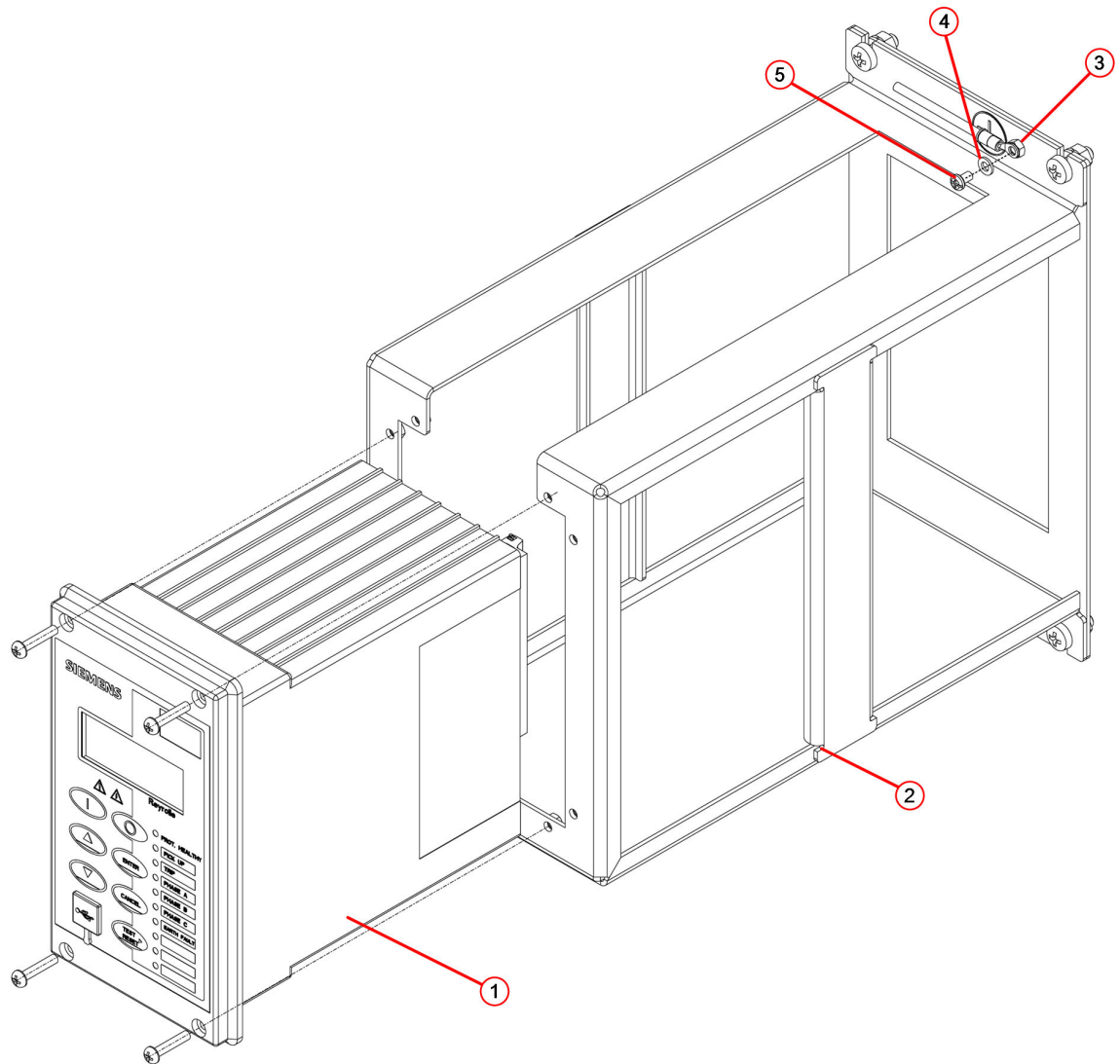

[dw_7SR10_surfacebracket_step2_1_en_US]

Figure 3-8 Fixing Relay to Surface-Mounting Bracket

- (1) 7SR10 relay
- (2) Surface-mount bracket
- (3) Grounding standoff
- (4) M4 stainless steel plain washer
- (5) M4x6mm stainless steel Phillips pan head machine screw



NOTE

Siemens recommends connecting the required cable assemblies to the rear end of the relay before fastening to the surface-mounting bracket.

- ✧ Route the cable assemblies from side ways opening of the surface-mounting bracket and connect them to the device.
- ✧ For grounding, fasten the M4x6mm stainless steel Phillips pan head machine screw with the M4 stainless steel plain washer to the grounding standoff provided on the surface mounting bracket.

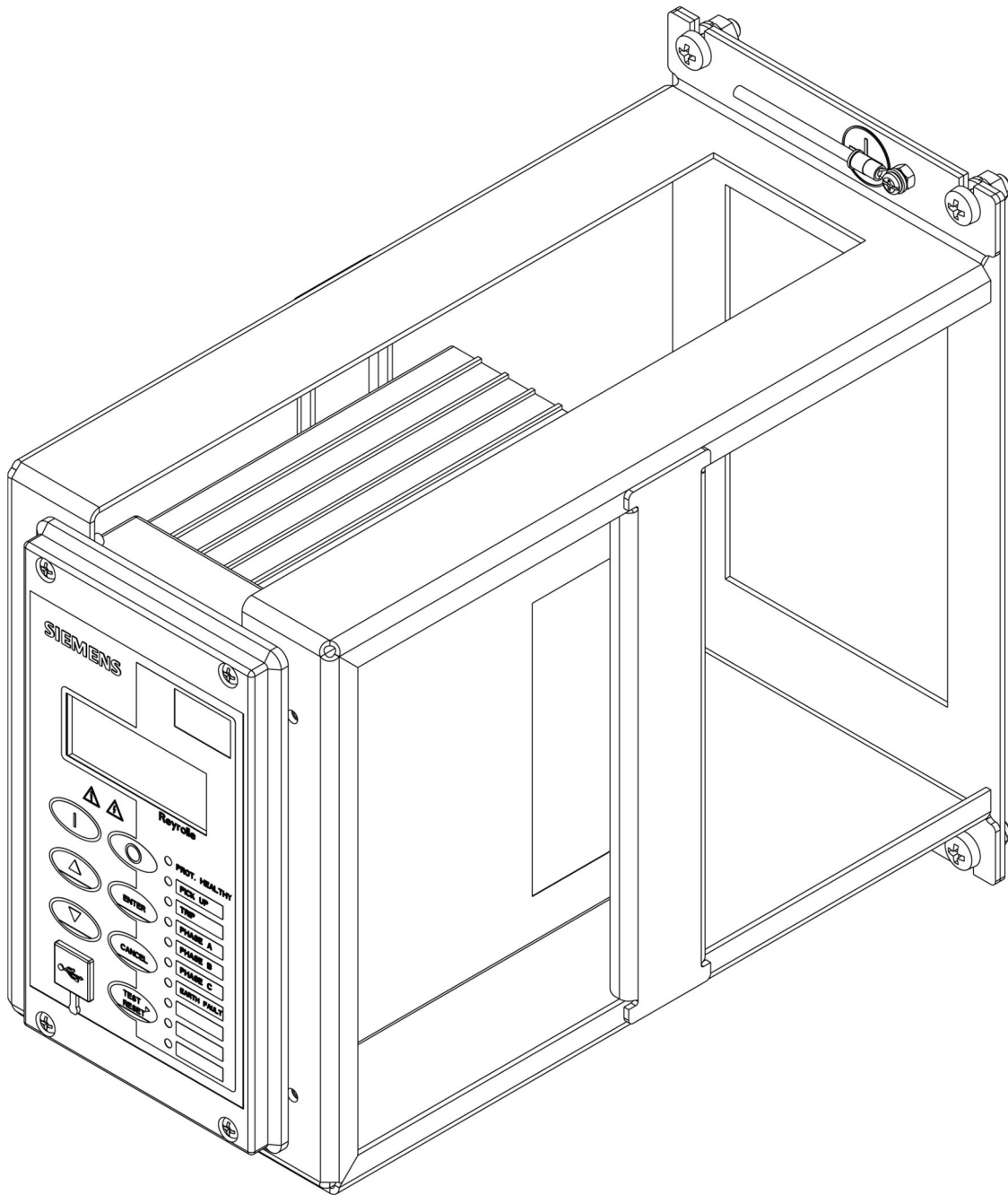

[dw_7SR10_surfacebracket_step3_1_en_US]

Figure 3-9 7SR10 Argus Relay fixed with Surface-Mounting Bracket

3.4 Replacement of the Device

Preparing for Replacement



DANGER

Danger due to live voltage when replacing the plug-in modules.

Noncompliance with the safety notes will result in death or severe injuries.

✧ Install the relay when it is completely disconnected from auxiliary-power supply.

- ✧ De-energize the device.
- ✧ Remove all connecting leads.
- ✧ Unscrew the fixed device.
- ✧ Carefully pull out the device.

Fastening the Device

- ✧ Insert the new relay into the panel opening.
 - ✧ Fix the device on the panel.
-



NOTE

The torque is indicated in the package or description of the device.

- ✧ Connect the leads to the terminals.
- ✧ Check for secure attachment of the connectors.
- ✧ If necessary, fit the on-site operation panel again.

Completing Replacement

- ✧ Place the device in service again.

4 Using the Device Fascia

4.1	General	38
4.2	Overview of Operator Elements and Display Elements	39
4.3	Structure of the Menu	43

4.1 General

Front Fascia

The front fascia is an integral part of the relay and allows you to access all the push-buttons and perform the setting changes and control actions. Using the push-button **TEST/RESET**, the fascia provides an option to reset the fault data display, latched binary output, and LEDs. The front fascia contains the label strip which provides the information about LED indicators.

The front fascia provides circuit-breaker (CB) control push-buttons to open and close the CB.

Front Fascia with Control Push-Buttons



[sc_7SR10_frontfascia, 1, en_US]

Figure 4-1 7SR10 Argus Overcurrent Relay with Control Push-Buttons

Operating Concept

The operating concept allows you to do the following on-site operator control actions:

- Navigating in the menu tree
- Viewing and modifying of parameter setting values
- Resetting saved information
- Showing default and control displays, measured values, and logs
- Executing switching operations
- Status display with LED
- Configuring functions
- Configuring CT/VT
- Displaying device information

4.2 Overview of Operator Elements and Display Elements

Liquid Crystal Display (LCD)

A 4 line by 20-character alphanumeric Liquid Crystal Display indicates

- Settings
- Instrumentation
- Fault data
- Control commands

To conserve power, the display backlighting is extinguished when no buttons are pressed for a user-defined period. With the setting **backlight timer** within the menu **SYSTEM CONFIG**, you can adjust the time-out from 1 min to 60 min and **OFF** (backlight permanently on). Pressing any push-button reactivates the display. You can program user-defined identifying text into the relay using the settings **SYSTEM CONFIG/Relay Identifier** and **SYSTEM CONFIG/Circuit Identifier**. The **Identifier** texts are displayed on the LCD display in 2 lines at the top level of the menu structure. The **Relay Identifier** is used in communication with the Reydisp software to identify the relay. If you press the push-button **CANCEL** several times, the LCD returns to the relay home screen.

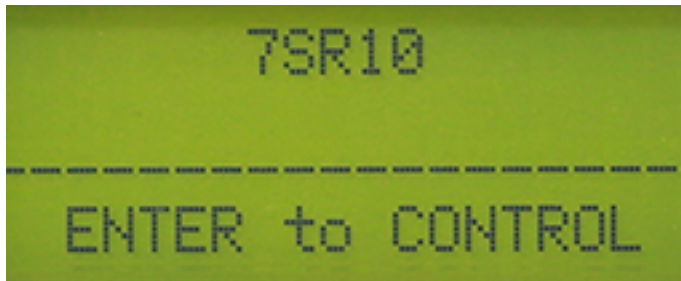

[sc_7sr10_relayIdentifier, 1, ---]

Figure 4-2 Relay Identifier – Home Screen

LCD Indication

General alarms are user-defined text messages displayed on the LCD when mapped to binary inputs or virtual inputs. Up to 6 general alarms of 16 characters can be programmed, each triggered from one or more inputs. Each general alarm will also generate an event.

If multiple alarms are activated simultaneously, then messages are displayed on a separate page in a rolling display on the LCD. With the setting **Enabled/Disabled** under **SYSTEM CONFIG → General Alarm Alert**, you select if the alarms are to be displayed on the LCD when active.

If a fault trigger is generated, all general alarms are raised and are logged into the fault-data record.

Push-Buttons



The standard relay is supplied with 7 push-buttons. These push-buttons are used to navigate in the menu structure and to control the relay functions. They are labeled:

Table 4-1 Push-Buttons

Push-Button	Description
▲	Increases a setting or moves up the menu. Used to navigate the menu structure.
▼	Decreases a setting or moves down the menu. Used to navigate the menu structure.

Push-Button	Description
TEST/RESET ▶	This push-button is used to reset the fault indication on the fascia. When you are on the relay identifier screen, it also acts as a LED test button. If you press the push-button, then all LEDs momentarily light up to indicate their correct operation. It also moves the cursor right ▶ when navigating through menus and settings.
ENTER	Used to initiate and accept settings changes. If a setting is displayed, press the push-button ENTER to enter the edit mode, then the setting flashes and can now be changed using the ▲ or ▼ push-buttons. If the required value is displayed, press the push-button ENTER again to accept the change.
CANCEL	Used to return the relay display to its initial status or one level up in the menu structure. If you press the push-button repeatedly, then you return to the relay identifier screen. It is also used to reject any alterations to a setting while in the edit mode.

The control push-buttons displayed in the following table are used in the following manner for the 7SR10 relay.

Push-Button	Function	Description
	CLOSE	Press the push-button CLOSE and confirm with ENTER to execute the closing operation of the circuit breaker
	OPEN	Press the push-button OPEN and confirm with ENTER to execute the opening operation of the circuit breaker



NOTE

You can access and set all settings and configurations of LEDs, BI, and BO using these push-buttons. Alternatively, the configuration/settings files can be loaded into the relay using the Reydisp software. When the **SYSTEM CONFIG → Setting Dependencies** is **ENABLED**, only the functions that are enabled appear in the menu structure.

CB Open/Close

The circuit breaker (CB) control function is used to manually open and close the circuit breaker when it is connected to the circuit. 2 dedicated push-buttons are provided on the front fascia to execute the CB manual close and open operations. Refer to [Table 4-1](#).

You can configure the binary input, binary output, and LED configuration for the CB opening and closing control operations.

To perform the CB opening and closing control operations, proceed as follows:

- On the relay identifier screen, press the control push-button **CB OPEN**. A confirmation pop-up appears.

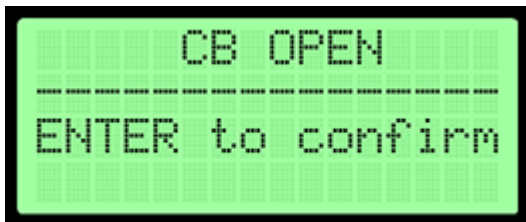

[lc_cb_lcd1, 1, en_US]

- Press the push-button **ENTER** to confirm.
- The delay count-down **CB: Opening** starts and reaches to zero.

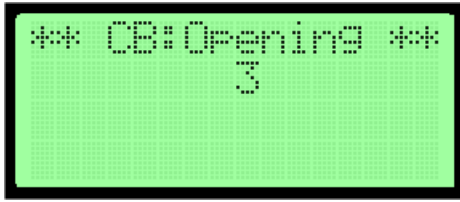

[sc_cb_led2, 1, en_US]

- The configured BO and LEDs for the control operation **CB OPEN** operates.
- To reset the LED and BO states, press the push-button **RESET**.

Repeat the same procedure for the control operation **CB CLOSE**.



NOTE

If the **Confirmation ID** (shown as **Password** in the relay LCD display) is already configured in the settings, then use the password to execute the CB opening/closing operations via control push-buttons. For more information about the function **Confirmation ID**, refer to [9.1 Confirmation ID \(Password Feature\)](#).



NOTE

If the operating mode of the 7SR10 relay is **Remote**, then you can perform the operations **CB Open** and **CB Close** when the setting **FUNCTION KEY CONFIG** is enabled.

Protection Healthy LED

If the green LED is steadily illuminated, then it indicates that the relay is healthy and is operating correctly. If the internal relay watchdog detects an internal fault, then the LED will not flash.

Indication LEDs

The 7SR10 relay has 9 user-programmable LEDs. Each LED can be programmed to be illuminated as either green, amber, or red. Where an LED is programmed to be lit both red and green, it illuminates amber. The same LED can be assigned 2 different colors dependent upon whether a start/pickup or operate condition exists. In the menu **OUTPUT CONFIG** → **LED CONFIG**, you can assign the LEDs to the pickup condition and select a color.

You assign functions to the LEDs in the menu **OUTPUT CONFIG** → **OUTPUT MATRIX**.

Each LED can be labeled by inserting a label strip into the pocket behind the front fascia. A **Template** is available in the Reydisp software to allow you to create and print customized legends.

Each LED can be programmed as hand reset or self-reset. Hand reset LEDs can be reset either by pressing the push-button **TEST/RESET** ►, by energizing a suitably programmed binary input, or by sending an appropriate command over the data communication channels.

If the supply voltage is interrupted, the status of hand reset LEDs is maintained by a backup storage capacitor.

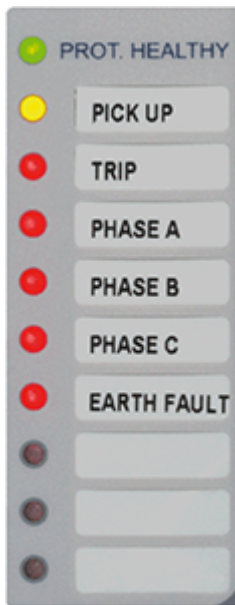

[sc_led_indicationlabel, 1, en_US]

Figure 4-3 7SR10 LED Indication with Labels

4.3 Structure of the Menu

4.3.1 Relay Menu

All 7SR10 relay fascias have the same appearance and support the same push-buttons. The basic menu structure is also the same in all products and consists of 4 main menus:

- Setting mode
- Instrument mode
- Fault data mode
- Control mode

Setting Mode

This mode allows you to view and (if allowed via passwords) change settings in the relay.

Instrument Mode

This mode allows you to view the following conditions of the relay:

- Current
- Voltage
- Input/output (I/O) status
- Miscellaneous status

Fault Data Mode

This mode allows you to see the type and data of any fault that the relay has detected.

Control Mode

This mode allows you to control an external plant by pressing the key **Control**. For example, CB Travelling, AR Out of Service.

The menu can be viewed without entering a password but if the relevant passwords have been set, actions will not be permitted.



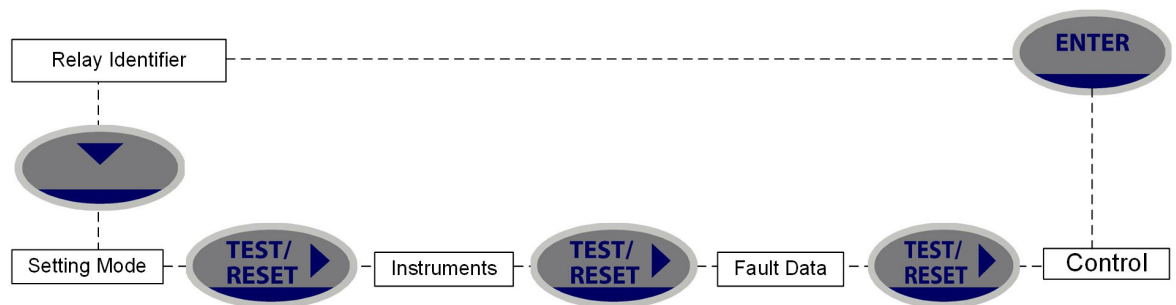

The menus can be viewed via the LCD by pressing the keys as:



[dw_relay_menus, 1, en_US]

Figure 4-4 Relay Menu

Table 4-2 Push-Buttons

Push-Button	Description
	Used to navigate in the menu structure or to increase the parameter value in the edit mode
	Used to navigate in the menu structure or to decrease the parameter value in the edit mode
	Used to reset the fault indication on the fascia If you press the push-button on the relay identifier screen, it also acts as a LED test button. It also moves the cursor right ► when navigating through menus and settings.
	Used to initiate and accept settings changes If a setting is displayed, pressing the push-button ENTER will enter the edit mode. The setting then flashes and can now be changed using the push-buttons ▲ or ▼. When the required value is displayed, press the push-button ENTER again to accept the change.
	Used to return the relay display to its initial status or one level up in the menu structure If you press the push-button repeatedly, you return to the relay identifier screen. It is also used to reject any alterations to a setting while in the edit mode.

4.3.2 User-Interface Operation

The flow chart of the basic menu structure shown in [4.3.6.1 7SR10 Menu Navigation Tree](#) and the main modes are:

- Setting mode
- Instrument mode
- Fault data mode
- Control mode

When the relay is shipped from the factory, all data-storage areas are cleared and the settings set to default as specified in the settings document.

When the relay is energized for the first time, the following message is displayed:



[sc_7SR10_device-lcd_enter, 1, --]

Figure 4-5 Relay Identifier Screen

In the factory default setup, the relay LCD displays the relay identifier.

The push-buttons on the fascia are used to display and edit the relay settings via the LCD:

- To display and activate the control segment of the relay
- To display the relays instrumentation and fault data
- To reset the output relays and LEDs

4.3.3 Setting Mode

You can reach **SETTING MODE** by pressing the push-button **READ DOWN(▼)** from the relay identifier screen. Once the settings mode screen is located, press the push-button **READ DOWN (▼)** which takes you into the submenus **SETTING MODE**.

Each submenu contains the programmable settings of the 7SR10 relay in separate logical groups. The submenus are accessed by pressing the push-button **TEST/RESET▶**. Press the push-button **▼** to scroll through the settings. After the last setting in each submenu is reached, the next submenu is displayed. If a particular submenu is not required to be viewed then pressing push-button **▼** will move directly to the next one in the list.

While a setting is being displayed on the screen, press the push-button **ENTER** to edit the setting value. If the relay setting is password-protected, you are prompted to enter the confirmation ID (password). Settings changes are only allowed after the correct confirmation ID is entered. If an incorrect confirmation ID is entered, editing is not permitted. The confirmation ID is not required to view and navigate to all screens.

When a setting is edited, flashing characters indicate the edit field. Press the push-buttons **▲** or **▼** to scroll through the valid field values. Hold the push-buttons **▲** or **▼** to increase the rate of scrolling.

Once you update the setting, press the push-button **ENTER** to store the setting in non-volatile memory. Press the push-button **CANCEL** to discard the changed settings.

4.3.4 Instrument Mode

The submenu **Instrument Mode** displays key quantities and information to aid with commissioning. The following meters are available and are navigated around using the push-buttons **▲**, **▼**, and **TEST/RESET▶**. The text description shown here is the default information. Depending upon the 7SR10 relay model you have, you may not have all of the meters shown.

Table 4-3 Instrument Mode

Instrument	Description
FAVORITE METERS → to view	<p>This allows you to view previously constructed list of FAVORITE METERS by pressing the push-button TEST/RESET▶ and ▼ to scroll though the meters added to this subgroup.</p> <p>To construct a sub-group of FAVORITE METERS, first go to the desired meter and press the push-button ENTER. This causes a message to appear on the LCD Add To Favorites YES. Press the push-button ENTER again to add this to the FAVOURITE METERS submenu.</p> <p>To remove a meter from the FAVORITE METERS go to that meter in the submenu FAVORITE METERS or at its primary location. Press the push-button ENTER, a message Remove From Favorites appears, press the push-button ENTER again and this meter is removed from the FAVORITE METERS subgroup.</p>
CURRENT METERS → to view	<p>This subgroup includes all the meters that are associated with current.</p> <p>The push-button TEST/RESET▶ allows you to access the subgroup.</p>
Primary Current I_a 0.00 A I_b 0.00 A I_c 0.00 A	Displays the 3 phase current primary RMS values.
Second'y Current I_a 0.00 A I_b 0.00 A I_c 0.00 A	Displays the 3 phase current secondary RMS values.
Nom Current I_a 0.00· $I_{n___}$ ° I_b 0.00· $I_{n___}$ ° I_c 0.00· $I_{n___}$ °	Directional relay: displays the phase currents, nominal RMS values, and phase angles with respect to PPS voltage. Non-directional relay: displays the phase currents, rated RMS values, and phase angles with respect to PPS current.
Pri Earth Current I_n 0.00 A I_g 0.00 A	Displays the ground current primary RMS values.
Sec Earth Current I_n 0.00 A I_g 0.00 A	Displays the ground current secondary RMS values.
Nom Earth Current I_n 0.00· $I_{n___}$ ° I_g 0.00· $I_{n___}$ °	Directional relay: displays the ground currents, rated RMS values, and phase angles with respect to PPS voltage. Non-directional relay: displays the ground currents, rated RMS values, and phase angles with respect to PPS current.
I Seq Components I_{zps} 0.00· $I_{n___}$ ° I_{pps} 0.00· $I_{n___}$ ° I_{nps} 0.00· $I_{n___}$ °	Directional relay: displays the current sequence components, rated RMS values, and phase angles with respect to PPS voltage. Non-directional relay: displays the current sequence components, rated RMS values, and phase angles with respect to PPS current.

Instrument	Description
2nd Harmonic Current $I_a 0.00 \cdot I_n$ $I_b 0.00 \cdot I_n$ $I_c 0.00 \cdot I_n$	Displays the second harmonic current
Last Trip P/F $I_a 0.00 \text{ A}$ $I_b 0.00 \text{ A}$ $I_c 0.00 \text{ A}$	Displays the last trip fault current
Last Trip E/F $I_n 0.00 \text{ A}$ $I_g 0.00 \text{ A}$	Displays the last trip ground-fault current
VOLTAGE METERS → to view	This subgroup includes all the meters that are associated with voltage. The push-button TEST/RESET ► allows you to access the subgroup.
Pri Ph-Ph Voltage $V_{ab} 0.00 \text{ kV}$ $V_{bc} 0.00 \text{ kV}$ $V_{ca} 0.00 \text{ kV}$	Displays the phase-to-phase voltage primary RMS values
Sec Ph-Ph Voltage $V_{ab} 0.00 \text{ V}$ $V_{bc} 0.00 \text{ V}$ $V_{ca} 0.00 \text{ V}$	Displays the phase-to-phase voltage secondary RMS values
Nominal Ph-Ph Voltage $V_{ab} 0.00\text{V} _ \text{ }^\circ$ $V_{bc} 0.00\text{V} _ \text{ }^\circ$ $V_{ca} 0.00\text{V} _ \text{ }^\circ$	Displays the phase-to-phase voltage, rated RMS values, and angles with respect to PPS voltage.
Pri Ph-N Voltage $V_a 0.00 \text{ kV}$ $V_b 0.00 \text{ kV}$ $V_c 0.00 \text{ kV}$	Displays the phase-to-ground voltage primary RMS values
Sec Ph-N Voltage $V_a 0.00 \text{ V}$ $V_b 0.00 \text{ V}$ $V_c 0.00 \text{ V}$	Displays the phase-to-ground voltage secondary RMS values
Nominal Ph-N Voltage $V_a 0.00 \text{ V} _ \text{ }^\circ$ $V_b 0.00 \text{ V} _ \text{ }^\circ$ $V_c 0.00 \text{ V} _ \text{ }^\circ$	Displays the phase-to-ground voltage, rated RMS values, and angles with respect to PPS voltage.
V Seq Components $V_{zps} 0.00 \text{ V} _ \text{ }^\circ$ $V_{pps} 0.00 \text{ V} _ \text{ }^\circ$ $V_{nps} 0.00 \text{ V} _ \text{ }^\circ$	Displays the voltage sequence components, rated RMS values, and phase angles with respect to PPS voltage.

Instrument	Description
Calc Earth Voltage Pri 0.00V Sec 0.00V ___°	Displays the calculated ground voltage both primary and secondary which also shows the secondary angle
Last Trip Voltage V _a 0.00 V V _b 0.00 V V _c 0.00 V	Displays the phase-to-ground voltage, and rated RMS values from last trip.
POWER METERS → to view	This subgroup includes all the meters that are associated with power. The push-button TEST/RESET▶ allows you to access the subgroup.
Phase A 0.0 W Phase B 0.0 W Phase C 0.0 W P (3P) 0.0 W	Displays the active power
Phase A 0.0 VAr Phase B 0.0 VAr Phase C 0.0 VAr Q (3P) 0.0 VAr	Displays the reactive power
Phase A 0.0 VA Phase B 0.0 VA Phase C 0.0 VA S (3P) 0.0 VA	Displays the apparent power
PF A 0.0 PF B 0.0 PF C 0.0 PF (3P) 0.0	Displays the power factor
P Phase A 0.0 S _n P Phase B 0.0 S _n P Phase C 0.0 S _n P (3P) 0.0 S _n	Displays the active-power rated values
Q Phase A 0.0 S _n Q Phase B 0.0 S _n Q Phase C 0.0 S _n Q (3P) 0.0 S _n	Displays the reactive-power rated values
S Phase A 0.0 S _n S Phase B 0.0 S _n S Phase C 0.0 S _n S (3P) 0.0 S _n	Displays the apparent-power rated values
ENERGY METERS → to view	This subgroup includes all the meters that are associated with energy. The push-button TEST/RESET▶ allows you to access the subgroup.
Active Energy Exp 0.00 kWh Imp 0.00 kWh	Displays both imported and exported active energy

Instrument	Description
Reactive Energy Exp 0.00 kVArh Imp 0.00 kVArh	Displays both imported and exported reactive energy
WATTMETRIC METERS → to view	This subgroup includes all the meters that are associated with Watt-metric. The push-button TEST/RESET▶ allows you to access the subgroup.
Ires R 0.000 A Pres 0.00 W Ires R Angle 0.0° I ₀ -V ₀ Angle	The Watt-metric component of the zero-sequence current Watt-metric residual power Compensated residual phase angle Applied residual phase angle
SEF 3V₀/I₀ METERS I ₀ 0.00 A ___° 3V ₀ 0.000 A ___° I ₀ -V ₀ 0.0°	The appropriate values from the selection are displayed.
DIRECTIONAL METERS → to view	This subgroup includes all the meters that are associated with measuring elements. The push-button TEST/RESET▶ allows you to access the subgroup.
P/F Dir (67) ----- No Dir, PhA Fwd, PhA Rev, PhB Fwd, PhB Rev, PhC Fwd, PhC Rev	The appropriate values from the selection are displayed.
Calc E/F Dir (67N) ----- No Dir, E/F Fwd, E/F Rev	The appropriate values from the selection are displayed.
Meas E/F Dir (67G) ----- No Dir, E/F Fwd, E/F Rev	The appropriate values from the selection are displayed.
SEF Dir (67SEF) ----- No Dir, SEF Fwd, SEF Rev	The appropriate values from the selection are displayed.
THERMAL METERS → to view	This is the subgroup that includes all the meters that are associated with thermal. The push-button TEST/RESET▶ allows you to access the subgroup.
Thermal Status Phase A 0.0% Phase B 0.0% Phase C 0.0%	Displays the thermal capacity
THD METERS → to view	This is the subgroup that includes all the meters that are associated with total harmonic distortion (THD). The push-button TEST/RESET▶ allows you to access the subgroup.

Instrument	Description
THD METERS Total Harmonic Dist. I_a THD 0.0% I_b THD 0.0% I_c THD 0.0%	This displays the percentage of 2 nd to 15 th harmonic current present in the fundamental frequency current.
AFD METERS → to view AFD Zone 1 count AFD Zone 2 count AFD Zone 3 count AFD Zone 4 count AFD Zone 5 count AFD Zone 6 count	This displays the zone-wise arc-fault detection (AFD) counters.
FREQUENCY METERS → to view	This is the subgroup that includes all the meters that are associated with frequency. The push-button TEST/RESET▶ allows you to access the subgroup. Available on selected variants, refer to ordering information.
Frequency 0.000 Hz Last Trip 0.000 Hz	Displays the frequency
AUTORECLOSE METERS → to view	This is the subgroup that includes all the meters that are associated with autoreclose. The push-button TEST/RESET▶ allows you to access the subgroup. Available on selected variants, refer to ordering information.
Autoreclose Status 79 AR State AR Close Shot 0	
MAINTENANCE METERS → to view	This is the subgroup that includes all the meters that are associated with maintenance. The push-button TEST/RESET▶ allows you to access the subgroup. Available on selected variants, refer to ordering information.
CB Total Trips Count 0 Target 100	Displays the number of CB trips experienced by the circuit breaker
CB Delta Trips Count 0 Target 100	Displays the number of CB delta trips experienced by the circuit breaker
CB Count To AR Block Count 0 Target 100	Displays the number of CB trips experienced by the circuit breaker. When the target is reached, the relay will only do 1 delayed trip to lockout
CB Freq Ops Count Count 0 Target 10	Displays the number of CB trips experienced by the circuit breaker over the last rolling 1 h period. When the target is reached, the relay will only do 1 delayed trip to lockout.

Instrument	Description
CB Wear Phase A 0.00MA ² s Phase B 0.00MA ² s Phase C 0.00MA ² s	Displays the current measure of circuit-breaker wear.
CB Wear Remaining Phase A 100% Phase B 100% Phase C 100%	Displays the current measure of circuit-breaker wear remaining.
CB Trip Time Time 0.0ms	Displays the circuit-breaker trip time to open time. Measured from CB auxiliary contacts.
GENERAL ALARM METERS → to view	This is the subgroup that includes all the meters that are associated with the general alarm The push-button TEST/RESET ► allows you to access the subgroup.
General Alarms ALARM 1 Cleared	Displays the state of general alarm.
General Alarms ALARM 2 Cleared	–
General Alarms ALARM 3 Cleared	–
General Alarms ALARM 4 Cleared	–
General Alarms ALARM 5 Cleared	–
General Alarms ALARM 6 Cleared	–
DEMAND METERS → to view	This is the subgroup that includes all the meters that are associated with demand. The push-button TEST/RESET ► allows you to access the subgroup.
I Phase A Demand Max 0.00 A Min 0.00 A Mean 0.00 A	Displays the current demand based on I _a
I Phase B Demand Max 0.00 A Min 0.00 A Mean 0.00 A	Displays the current demand based on I _b
I Phase C Demand Max 0.00 A Min 0.00 A Mean 0.00 A	Displays the current demand based on I _c
V Phase A Demand Max 0.00 V Min 0.00 V Mean 0.00 V	Displays the voltage demand based on V _a

Instrument	Description
V Phase B Demand Max 0.00 V Min 0.00 V Mean 0.00 V	Displays the voltage demand based on V_b
V Phase C Demand Max 0.00 V Min 0.00 V Mean 0.00 V	Displays the voltage demand based on V_c
V Phase AB Demand Max 0.00 V Min 0.00 V Mean 0.00 V	Displays the voltage demand based on V_{ab}
V Phase BC Demand Max 0.00 V Min 0.00 V Mean 0.00 V	Displays the voltage demand based on V_{bc}
V Phase CA Demand Max 0.00 V Min 0.00 V Mean 0.00 V	Displays the voltage demand based on V_{ca}
Power P 3P Demand Max 0.00 W Min 0.00 W Mean 0.00 W	Displays the active-power demand.
Power Q 3P Demand Max 0.00 VAr Min 0.00 VAr Mean 0.00 VAr	Displays the reactive-power demand.
Power S 3P Demand Max 0.00 VA Min 0.00 VA Mean 0.00 VA	Displays the apparent-power demand.
Frequency Demand Max 0.000 Hz Min 0.000 Hz Mean 0.000 Hz	Displays the frequency demand.
MISCELLANEOUS METERS → to view	This is the subgroup that includes indication such as the relays time and date, the amount of fault, and waveform records stored in the relay. The push-button TEST/RESET allows you to access the subgroup.
Start Alarm Count 0 Target 100	Count of configurable type of the 7SR10 relay starts and target setting for start alarm.
Date 01/01/2000 Time 22:41:44 Waveform Recs 0 Fault Recs 0	This meter displays the date and time and the number of fault records and event records stored in the relay.

Instrument	Description
Event Recs 0 Data Log Recs 0 Setting Group 1	–
BINARY INPUT METERS → to view	This is the subgroup that includes all the meters that are associated with the binary inputs. The push-button TEST/RESET ▶ allows you to access this subgroup.
BI 1-9 ___ ___	Displays the state of the binary inputs 1 to 9 (The number of binary inputs varies depending on relay)
BINARY OUTPUT METERS → to view	This is the subgroup that includes all the meters that are associated with the binary outputs. The push-button TEST/RESET ▶ allows you to access this subgroup.
BO 1-6 ___ ___	Displays the state of the binary outputs 1 to 6 (The number of binary outputs varies depending on relay)
VIRTUAL METERS → to view	This is the subgroup that shows the state of the virtual status inputs in the relay. The push-button TEST/RESET ▶ allows you to access this subgroup.
V 1-8 ___ ___	Displays the state of the virtual outputs 1 to 8
COMMUNICATION METERS → to view	This is the subgroup that includes all the meters that are associated with communications ports. The push-button TEST/RESET ▶ allows you to access this subgroup.
COM1 COM2	Displays the active ports
COM1 TRAFFIC COM1 Tx1 0 COM1 Rx1 0 COM1 Rx1 Error 0	Displays data traffic on communication port 1
COM2 TRAFFIC COM2 Tx1 0 COM2 Rx1 0 COM2 Rx1 Error 0	Displays data traffic on communication port 2
QUICK LOGIC METERS → to view	This is the subgroup that includes all the meters that are associated with QuickLogic Equations . The push-button TEST/RESET ▶ allows you to access this subgroup.
E 1-4 ___	Displays the state of QuickLogic Equations 1 to 4
E1 Equation EQN =0 TMR 0-0 =0 CNT 0-1 =0	–
E2 Equation EQN =0 TMR 0-0 =0 CNT 0-1 =0	–

Instrument	Description
E3 Equation EQN =0 TMR 0-0 =0 CNT 0-1 =0	-
E4 Equation EQN =0 TMR 0-0 =0 CNT 0-1 =0	-

4.3.5 Fault Data Mode

The submenu **Fault Data Mode** lists the time, date, and fault information of the last 100 protection operations. You can view the stored data about each fault by pressing the push-button **TEST/RESET▶**. Each record contains data on the operated elements, analog values, and LED flag states at the time of the fault. The data is viewed by scrolling down using the push-button **▼**.

4.3.6 Menu Tree

4.3.6.1 7SR10 Menu Navigation Tree

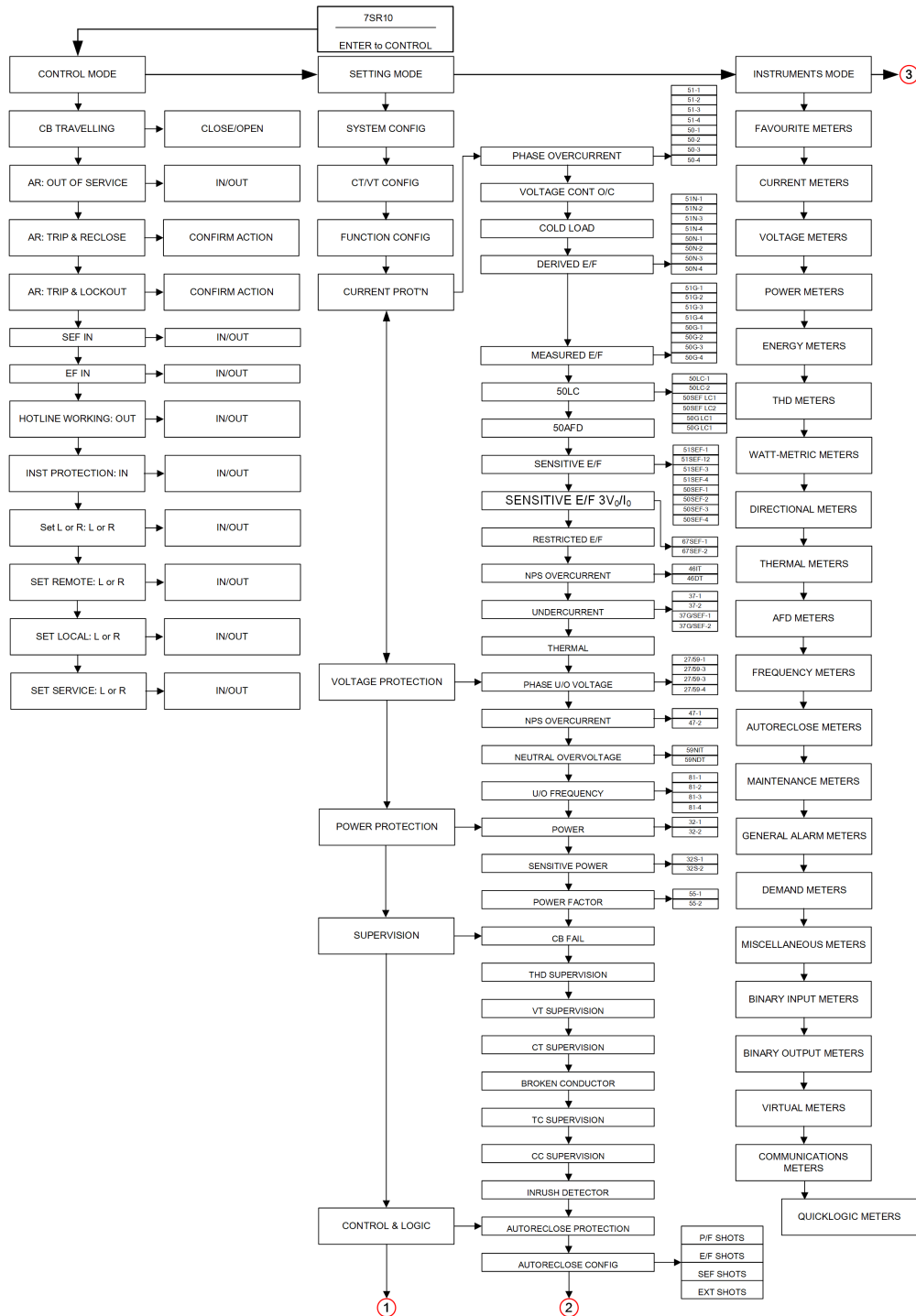

[dw_7sr10menu-structure, 1_en_US]

Figure 4-6 7SR10 Menu Structure

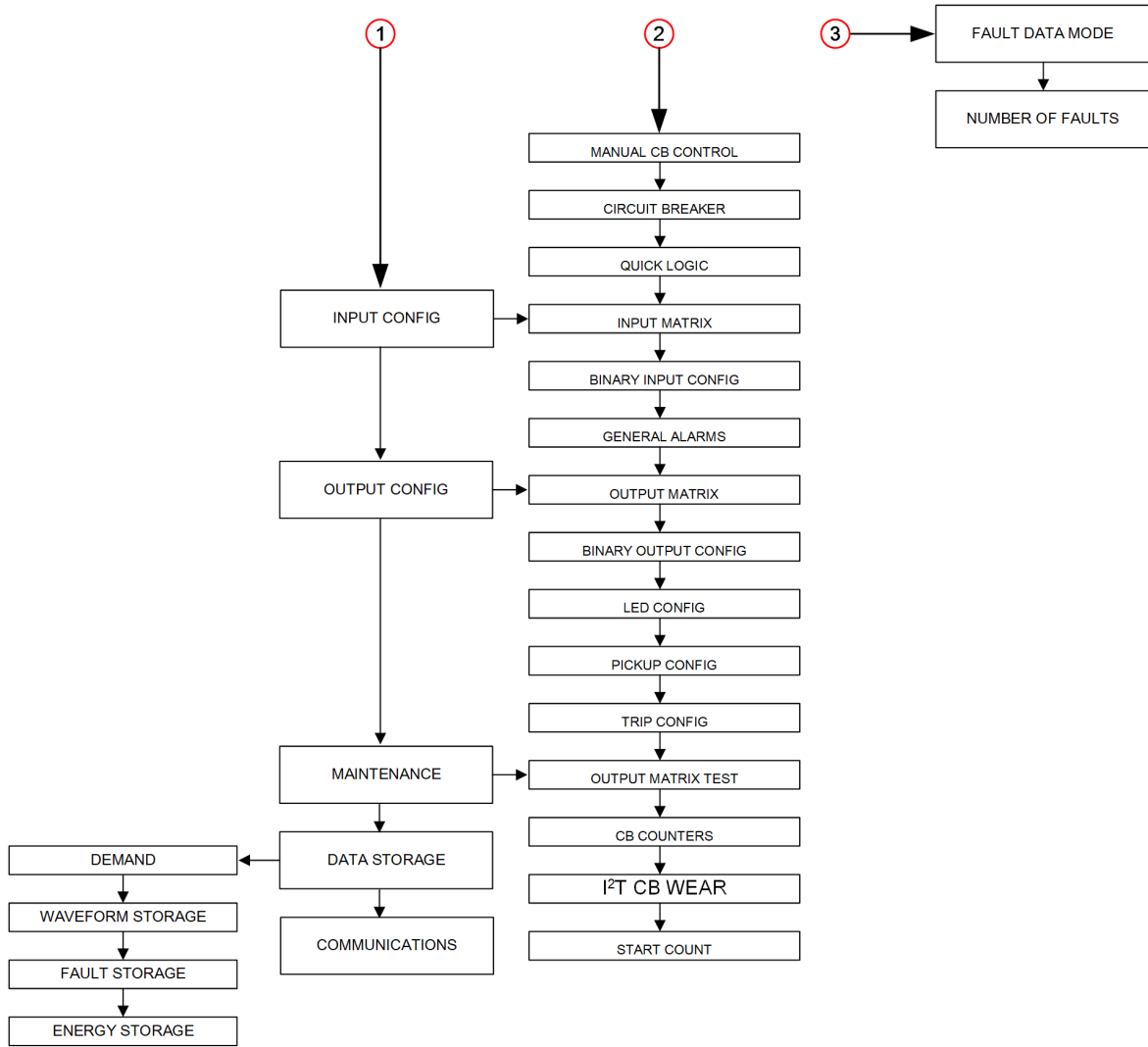

[dw_7sr10menu-structure_continued, 1, en_US]

Figure 4-7 7SR10 Menu Structure (Continued)

5 Using Reydisp Software

5.1	Reydisp Evolution Software	58
5.2	Reydisp Manager Software	59

5.1 Reydisp Evolution Software

The Reydisp Evolution is a Windows-based suite of software tools, providing you to fully configure the 7SR10 relay and is common to the entire range of Reyrolle protection devices.

The setting configuration tool allows you to apply settings, interrogate settings, and retrieve events and disturbance waveforms from the device.

Reydisp Evolution is free of charge and can be downloaded directly from this Siemens Internet page: www.siemens.com/reyrolle. The PC program works with common Windows operating systems including Windows XP.

The Language Editor software gives you the ability to customize the text displayed in the relays, menu structure, and instrumentation views. The tool allows a language file to be created and transferred to the relay containing any Western European characters.

To facilitate easier interfacing to a substation, the relays default protocol configuration can be modified using the Communication Editor software tool. The communication editor is a PC-based software package provided within the Reydisp suite which allows modification of the data points available from the relays associated with the IEC 60870-5-103, DNP3, and Modbus protocols.

The Curve Editor software allows the creation of IDMTL curves for 7SR10 relays, which allows to have more flexibility when grading with other devices. It can import existing curves, create new curves from templates, and send the curves to the relay.

Functions:

- Setting editor and parameter configuration
- Fault analysis with visualization of waveforms
- Device control and online monitoring
- Communication Editor
- Curve Editor
- Language Editor

For further information on device configuration and device settings, refer to the *7SR10 Engineering Guide*.

5.2 Reydisp Manager Software

Reydisp Manager is a Windows-based software tool which is used for the configuration of 7SR10 relays. The interface is used for easy management of the user files to fully configure 7SR10 relays which include:

- Functional configuration
- Logic configuration
- User-defined characteristic curves
- Parameter setting
- Data communication interfaces

Reydisp Manager allows project-level configurations with multiple devices.

Reydisp Manager and templates are free of charge and can be downloaded directly from the Siemens Internet site under submenu: www.siemens.com/reynolle.

Reydisp Manager templates must be installed, before using Reydisp Manager. A template is required for each 7SR10 relay or a software version that is to be used.

Functions

- Project configuration with multiple devices
- Create and edit logic diagrams
- Configure device settings
- Device template management
- Firmware upload
- Device migration
- Communication Editor
- Curve Editor
- Language Editor

For further information on device configuration and device settings, refer to the *7SR10 Engineering Guide*.

6 In Service Operation

6.1	Overview	62
6.2	Safety Notes	63
6.3	Operation Options	64
6.4	Indications	65
6.5	Reading Fault Data from the Relay LCD	66
6.6	Reading Fault Event Data and Waveform Records from Reydisp Evolution	67
6.7	Logs	69
6.8	Metering	73
6.9	Operating Mode	74
6.10	Control Mode	75
6.11	Real-Time Clock (RTC)	76
6.12	Change Device Settings	77
6.13	Settings Group	79
6.14	User-Specific Curves	80

6.1 Overview

This section describes the handling of a 7SR10 relay in the operating state. It contains the following information:

- Reading information from the device
- Using the functions of the device when in service

6.2 Safety Notes

Authorized Operational Crew



DANGER

Danger due to inadmissible or improper operator control actions.

Non-compliance with the safety notes will result in death or severe injuries.

✧ Only personnel who are qualified professional with precise knowledge of the system may operate devices during operation.

✧ Carry out all operator control actions in the indicated sequence.



NOTE

Operator control actions are password protected. This ensures that only operational crew members with access rights can use the device during operation.

6.3 Operation Options

6.3.1 General

The device is operated via a Reydisp software or directly using the fascia keys. You have the following operating options during operation:

- Readout of indications
- Readout, backup, and deletion of event logs and fault records
- Resetting event counters
- Changing device settings such as date, time, and interface language
- Changing confirmation ID (password)
- Changing function parameters and switching of settings groups
- Switching operating modes



NOTE

Reydisp Software Communication

Operation using a Reydisp software requires a functioning communication connection from the Reydisp software to the device. For this purpose, you can use the USB interface on the fascia.



NOTE

Protection from Operating Errors and Unauthorized Access

Operator

Changes to device settings and the deletion of process data can be prevented by enabling the setting confirmation IDs. After entering the setting ID, if no action takes place within certain times (60 min after the last push-button press, or if the Control ID is entered), an open confirmation query is automatically terminated. Every action carried out within these times restarts the time. After a confirmation query has ended, you must confirm changes in device settings again by entering the confirmation IDs.

For more information on online and offline operation of the Reydisp software, refer to the *7RS10 Engineering Guide*.

6.4 Indications

6.4.1 General

During operation of the 7SR10 relay, indications provide information about operating states:

- Measured data
- Device supervisions
- Device functions

In addition, indications give an overview of important fault events after a failure in the system. All indications include the date, time, and state.

Indications are saved in logs inside the device and are available for later analyses. The following number of indications are saved at least in the respective buffer (depending on the scope of the indications):

- Event log: 1000 indications
- Fault log: 100 indications
- Waveform log: 15 indications maximum
- Data log, average values of current, voltage, and power (where applicable)

If the maximum capacity of the user-defined log or operational log is exhausted, the oldest entries disappear before the newest entries. During a supply-voltage failure, recorded data are securely held by storage in the memory. You can read and analyze the log from the device with Reydisp software. The device display and by navigation keys allow you to read and analyze the logs on-site.

Indications can be generated spontaneously via the communication interfaces of the device and through external request via general interrogation.

Reading Indications

To read the indications of the 7SR10 relay, you can use the LCD display of the device or a PC on which you have installed the Reydisp software. The subsequent section describes the general procedure.

6.4.2 Displaying Indications

Displayed indications in the Reydisp software and on the on-site operation panel are supplemented with the following information:

Table 6-1 Overview of Additional Information

Indications in	Reydisp Information	Device Display Information
Log for operational indications	Time stamp (date and time), Function type, Function action, and Function description	–
Log for fault indications	Entry number Time stamp (date and time) Settings group number Function name Current and voltage values	Entry number Time stamp (date and time) Settings groups number Function name Current and voltage values

6.5 Reading Fault Data from the Relay LCD

Fault indications are events which arise during a fault. Fault indications are triggered from the setting **Trip Config** which must be set to the trip contact. A fault starts by the incoming pickup of a protection function and ends after the trip command with the pickup cleared.

Fault-data records can be viewed on the relay LCD with the time and date of the trip. These records also include the LED status at the time of recording and the fault information.

Available fault data is displayed in **Main Menu** → **Fault Data** with date and time format. If no faults are stored, then the display indicates **No Faults**. Previous fault data records are stored with the actual LEDs status. The fault data is displayed in date/time order with the most recent first.



NOTE

Trip Binary Output must be configured as a trip contact from **Binary Outputs** → **Trip Config** → **Trip Contacts** to initiate a fault record and trip screen.

After a fault, the most important data of the last fault is displayed automatically on the device display with operational fault measures. **Trip Alert** must be enabled from menu **Configuration** → **Device Settings**.



NOTE

If the fault screen has not been acknowledged, the LEDs remains illuminated when viewing other screens. These displays remain stored in the device until they are acknowledged manually or released by LED reset

6.6 Reading Fault Event Data and Waveform Records from Reydisp Evolution

- ✧ To read fault data from the PC connected to the 7SR10 relay, open Reydisp Evolution and click the tab **Get Data Fault Records** to retrieve fault records (Figure 6-2).

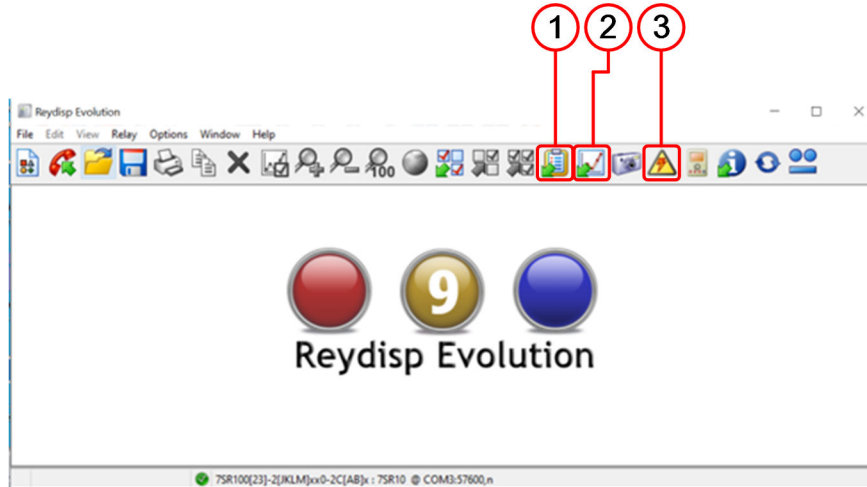

[file_7sr10_reydispevol_start, 1, en_US]

Figure 6-1 Reydisp Evolution Software

- (1) Get events tab
- (2) Get waveform record tab
- (3) Get data fault records tab

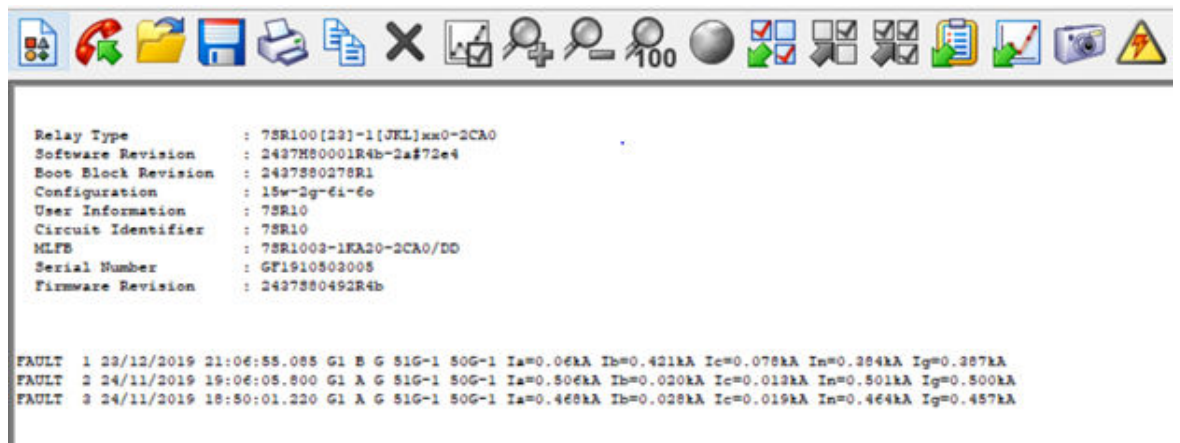

[sc_7sr10reydisp_evolution_fault, 1, --]

Figure 6-2 7SR10 Relay, Fault Record Window

- ✧ To retrieve event records and waveform records, click the tab **Get Events** or **Get Waveform Record**.

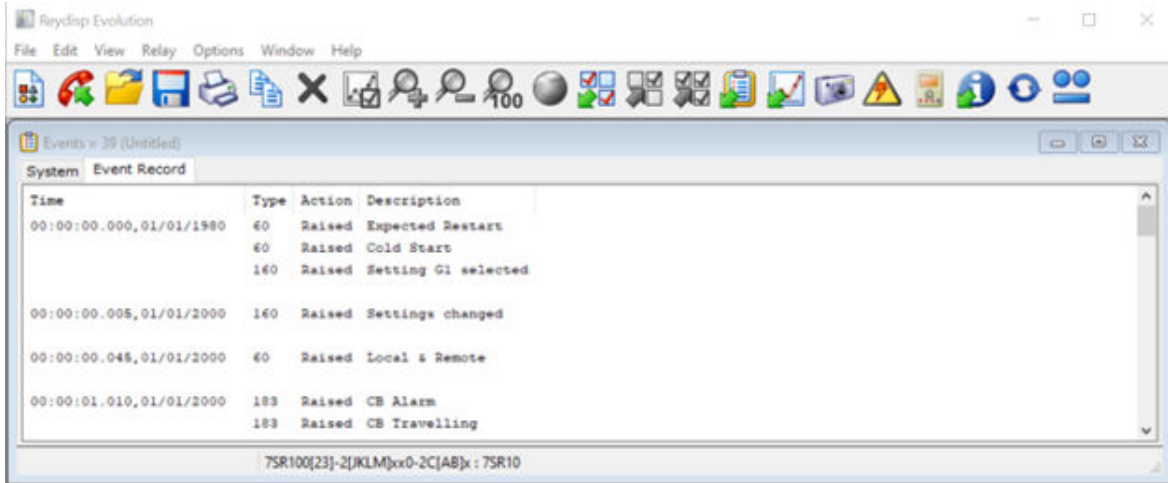

[sc_7sr10reydisp_evolution_event, 1, ...]

Figure 6-3 Event Record Window

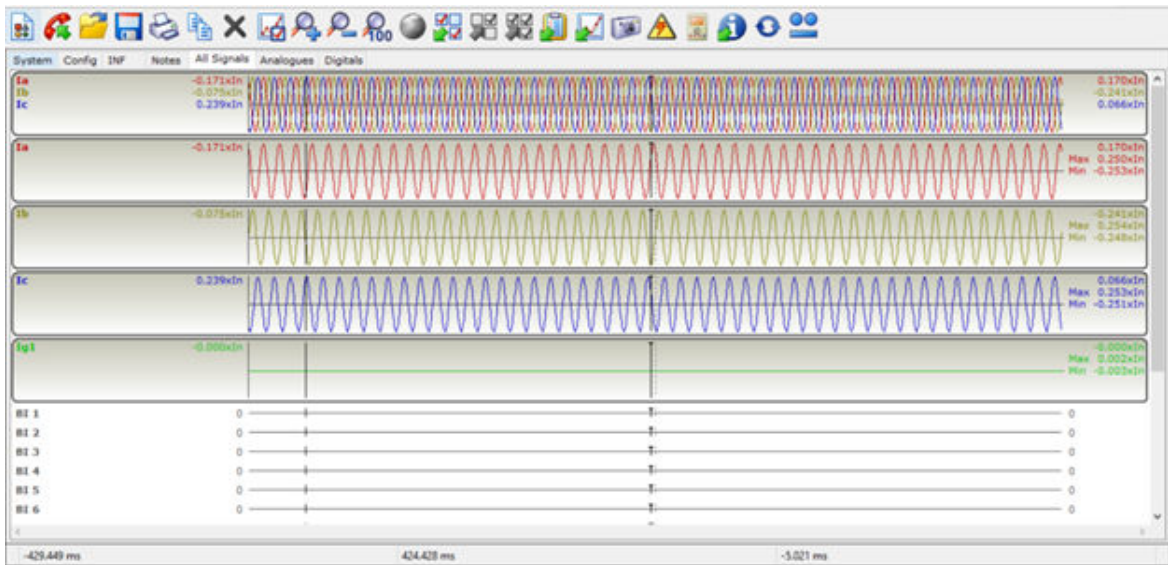

[sc_7sr10reydisp_evolution_waveform, 1, ...]

Figure 6-4 Waveform Record Window

- ✧ Initially, for each type of device, there are default views defined for analog channels, digital channels and all channels. You can create views or modify existing views, edit the analog-channel information, and format the display using the command **View → Properties**.

6.7 Logs

6.7.1 Data Storage

The relay stores 3 types of data – relay event records, analog/digital waveform records, and fault records. If there is a loss of auxiliary-supply voltage, then data records are backed up in non-volatile memory and are permanently stored. The menu **DATA STORAGE** contains the settings for the features demand, waveform, fault recording, event storage, and energy storage.

Demand

The maximum, minimum, and mean values of the following are available as instruments:

- Phase currents
- Voltages
- Power
- Frequency

These values can be read in the 7SR10 relay menu **INSTRUMENTS** or via the Reydisp software.

The setting **Gn Demand Window** defines the maximum period of time over which the demand values are valid. A new set of demand values is established after expiry of the set time.

The type **Gn Demand Window** can be set to **FIXED** or **PEAK** or **ROLLING**.

- When set to **FIXED**, the maximum, minimum, and mean values demand statistics and are calculated over fixed window duration. At the end of each window, the internal statistics are reset and a new window is started.
- When set to **PEAK**, the maximum and minimum values are reset and recorded.
- When set to **ROLLING**, the maximum, minimum, and mean values demand statistics and are calculated over a moving window duration.

The internal statistics are updated when the window advances every updated period. The statistics can be reset from a binary input or communication command, after a window duration is immediately restarted.

Event Records

The event recorder feature allows the time tagging of any status change (event) in the relay. When an event occurs, the actual event condition is logged as a record along with a time and date stamp to a resolution of 1 ms. A maximum of 1000 event records can be stored in the 7SR10 relay and when the operational log is full, any new record overwrites the oldest.

Stored events can be cleared by using the setting **DATA STORAGE** → **Clear Events** or from the Reydisp software.

The following events are logged:

- Status change of binary outputs
- Status change of binary inputs
- Change of settings and settings group
- Status change of any of the control functions of the relay
- Protection-element operation

All events can be uploaded over the data communication channels and can be displayed in the Reydisp software in chronological order allowing the sequence of events to be viewed. Events can be selected to be made available spontaneously to a control system compliant with IEC 60870-5-103, Modbus RTU, or DNP3. The function number and event number can also be changed. The events are selected and edited using the Reydisp software.

Waveform Records

The waveform storage of the 7SR10 relay can be triggered either by selecting the relay operations from the:

- Relay fascia with a suitably programmed binary input
- Data communication channels
- Protection-function operations

The stored analog and digital waveforms illustrates the system and relay conditions at the time of trigger. An output is provided to indicate when a new record is stored.

A waveform can also be stored from the relay fascia using the setting **DATA STORAGE** → **Waveform Storage** → **Trigger Waveform**. Waveforms are sampled at a rate of 1600 Hz.

In total, the relay provides 15 s of waveform storage, which is user-selectable to **15 Rec x 1 Sec, 7 Rec x 2 Sec, 3 Rec x 5 Sec, 1 Rec x 15 Sec** records. When the waveform-recorder buffer is full, any new waveform record overwrites the oldest.

You can select the percentage of the waveform storage before triggering.

Stored waveforms can be erased using the setting **DATA STORAGE** → **Clear Waveforms** or from the Reydisp software.

Fault Records

The last 100 fault records can be stored and displayed on the relay LCD. Fault records are user-selectable via standard relay operation. You configure an output via setting **OUTPUT MATRIX** → **TRIP CONFIG** → **TRIP CONTACTS** or via a suitably programmed binary input. An output is provided to indicate when a new record has been stored.

Fault records provide a summary of the relay status at the time of trip. For example:

- The element that issued the trip
- Any elements that were picked up
- The fault type
- LED indications
- Date and time

The setting **Max Fault Rec. Time** sets the time range from fault trigger during which the summary of the relay status is recorded. This is recorded until the fault is active or the **Max Fault Rec. Time** expires, whichever is earlier.

The relay can be set to display the fault record automatically on the relay LCD when a fault occurs. When the trip alert is enabled from setting **SYSTEM CONFIG** → **Trip Alert**, the fault record is displayed until reset.

When examined together, the event and fault records detail the full sequence of events leading to a trip.

Fault records are stored in a rolling buffer, with the oldest faults over-written. The fault records can be cleared with the setting **DATA STORAGE** → **Clear Faults**.

The fault-recorder summary is available in 2 different options:

- From the relay LCD via **DATA STORAGE** → **FAULT STORAGE** → **Fault Rec Value** or
- From the Reydisp software

You can select any one of the following options:

- **Trip:**
The RMS value of the fault current or voltage is captured during the trip initiation.
- **Max after Trip:**
The maximum RMS value of fault current and voltage is captured during the trip initiation.

Energy Storage

The measured power is continuously integrated (over a 1-s window) to produce 4 energy quantities:

- Active export energy (W)
- Active import energy (W)
- Reactive export energy (VAr)
- Reactive import energy (VAr)

The direction of energy transfer is set by: **SYSTEM CONFIG** → **Export Power/Lag VAr**. With both **Export Power (W)** and **Lag VAr (VAr)** set to be **+ve**, the direction of energy transfer follows the IEC convention as shown in [Figure 6-5](#).

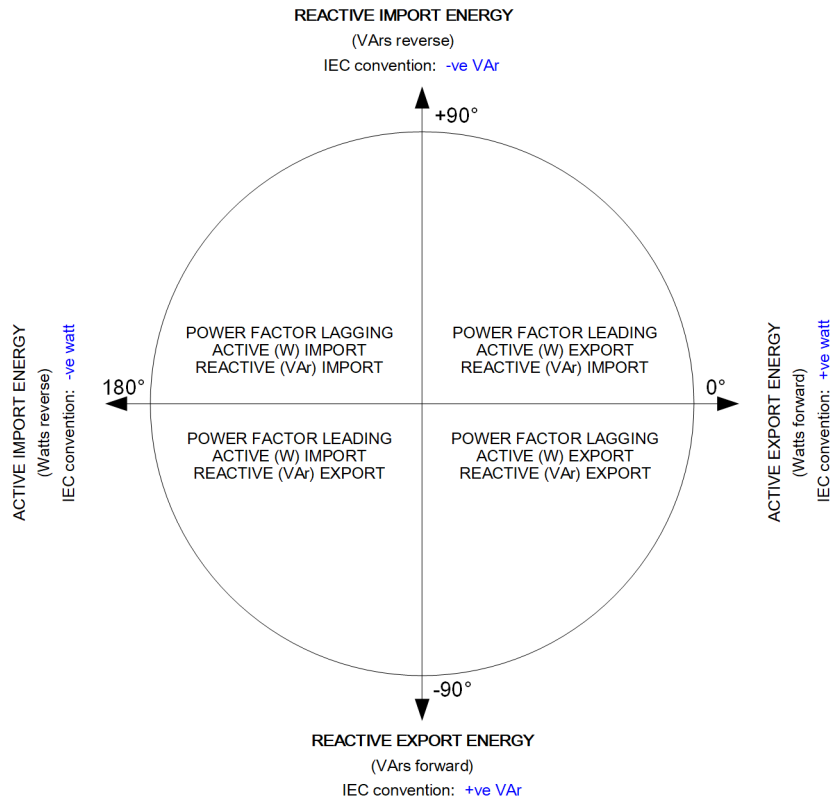

[dwr_7SR10_energydirection. 2. en_US]

Figure 6-5 Energy Direction Convention

Setting either the **Export Power (W)** or **Lag VAr (VAr)** to be **-ve** will reverse the direction of the energy transfer for these quantities. So forward VAr will then be reported as **Imported Reactive Energy**, and forward Watts will be reported as **Exported Active Energy**.

When the accumulated energy quantities reach a set increment, the relay issues a pulse to the binary outputs: **OUTPUT CONFIG** ► **OUTPUT MATRIX** → **Active Exp Pulse**, **Active Imp Pulse**, **Reactive Exp Pulse**, and **Reactive Imp Pulse**.

The energy increments are set by the settings: **DATA STORAGE** → **ENERGY STORAGE** → **Active Exp Energy Unit**, **Active Imp Energy Unit**, **Reactive Exp Energy Unit**, and **Reactive Imp Energy Unit**. These settings also define the resolution of the stored energy values reported by instruments and communication protocols. The value is stored in the range 0 to 999 999 which continues from 0 automatically when 999 999 is reached.

Disk Activity Warning

The data-storage facilities offered by the 7SR10 relay involve archiving a huge amount of data to non-volatile memory. Since such functionality is always secondary to the protection functionality, the data transmissions can take a significant amount of time in minutes. If the relay is power-cycled during a storage cycle, then

some of the data is lost. For this reason, the relay can provide a visual warning (at the top-right position of the relay LCD) that data storage is taking place.

- The **oe** disk symbol indicates that the copying of events, waveform records, or fault records to the non-volatile disk storage is in progress.
- You can enable **oe** under setting **SYS CONFIG → Disk Activity Symbol**.

To avoid such data archiving causing a delayed response of the relay LCD during testing or commissioning, when a considerable number of new data records are likely to be created, it is possible to temporarily suspend it. The duration of this block is set by the setting **SYS CONFIG → Archiver Blocking Time**. Once this time has elapsed, the block is removed and all stored data are archived as usual.

The **A** symbol at the top-right position of the relay LCD indicates that new events, waveform records, or fault records are currently being held in the volatile RAM. During this process, archiving to the non-volatile flash disk storage is temporarily blocked.

6.8 Metering

The metering feature provides real-time data available from the 7SR10 relay. You can navigate to various meters from the relay LCD **Instruments Mode** or via the data communications interface.

The primary values are calculated using the CT ratios set in the menu **CT/VT CONFIG**.

The text displayed in the relay **Instruments Mode** is associated with a value, which can be changed from the default text using the Reydisp software.

You can add the meters that are most commonly viewed to a window **Favourites** by pressing the push-button **ENTER** when viewing a meter. The relay will scroll through these meters at an interval set in the menu **FAVORITE METERS → Timer**.

6.9 Operating Mode

The device has 3 operating modes:

- Local
- Remote
- Out of Service

These operating modes can be selected either from the setting **SYSTEM CONFIG** → **OPERATING MODE**, a binary input, or command.

The following table illustrates whether a function is **Enabled** (✓) or **Disabled** (✗) in each mode.

Table 6-2 Operating Mode Table

Function	Operating Mode		
	Local	Remote	Out of Service
Control			
Com1	✓ when Com1-Mode = Local	✓ when Com1-Mode = Remote	X
Com2 (USB)	✓ when Com2-Mode = Local	✓ when Com2-Mode = Remote	X
Fascia (Control Mode)	✓	X	X
Function key (n)	✓	✓ when F Key(n) Mode = Remote	X
Binary input (n)	✓ when BI (n) Mode = Local	✓ when BI (n) Mode = Remote	X
Binary outputs	✓	✓	X
Reporting			
Spontaneous			
IEC	✓	✓	X
DNP3	✓	✓	X
General interrogation			
IEC	✓	✓	X
DNP3	✓	✓	✓
MODBUS	✓	✓	✓
Change settings			
Com1	✓ when Com1-Mode = Local	✓ when Com1-Mode = Remote	✓
Com2 (USB)	✓ when Com2-Mode = Local	✓ when Com2-Mode = Remote	✓
Fascia	✓	✓	✓
Historical information			
Waveform Records	✓	✓	✓
Event Records	✓	✓	✓
Fault Information	✓	✓	✓
Setting Information	✓	✓	✓

6.10 Control Mode

The control mode provides convenient access to commonly used relay control and test functions by:

- CB control
- Earth fault in/out (E/F In)
- Set local or remote
- Set remote
- Set local
- Set service

When any of the control modes are selected, the control is initiated by pressing the key **ENTER**. You can confirm the action, again by pressing the key **ENTER**, before the command is executed.



NOTE

The CB must be in a closed state before a trip command is accepted. The CB must be in an open state before any close command is accepted. Otherwise, the relay reports the requested command as **Interlocked**.

Switching a protection function In/Out via the menu **Control Mode** does not change the function setting **ENABLED/DISABLED**. However, the **Control Mode** selection overrides the setting.

Control mode commands are password protected using the password feature. For more information, refer to [9.1 Confirmation ID \(Password Feature\)](#).

6.11 Real-Time Clock (RTC)

Time and date can be set either via the relay LCD from the menu **SYSTEM CONFIG** or from the data communication channels. Time and date are maintained when the relay is de-energized by a backup storage capacitor. The length of time for which the data is maintained depends on the temperature and on the length of time in service. However, the data is maintained for a minimum of 1 day.

To maintain synchronization within a substation, the relay can be synchronized to the nearest second or minute using the communications interface or a binary input.

The devices without an external synchronization can have a maximum drift of ± 2 s/day.

The following attribute is applicable only when no synchronization signal (example: IEC 60870-5-103) is received.

Attribute	Value
Accuracy (-10 °C to 60 °C)	± 60 p.p.m

The default date is set to 01/01/2000 deliberately to indicate that the date has not yet been set. When editing the **Time**, you can only edit the hours and minutes. After editing, when you press the push-button **ENTER**, the seconds are set to zero and the clock starts.

Time Synchronization – Data Communication Interface

When the data communication channels are connected, the relay can be directly time synchronized using the global time synchronization. The communication can be achieved from a dedicated substation automation system or from Reydisp software communications.

Time Synchronization – Binary Input

A binary input can be mapped **Clock Sync from BI**. The seconds or minutes are rounded up or down to the nearest value when the BI is energized. This input triggers the time synchronization.

6.12 Change Device Settings

Date and Time Synchronization

The integrated date and time synchronization of the 7SR10 relay allows you to assign the precise time of events to an internally maintained device time. Events in the logs are stamped with the device time.

Setting Time and Date

You can set the date and time of the 7SR10 relay using the relay LCD and the Reydisp software.

Settings on the Device Using the On-Site Operation Panel

To reach the settings for date and time from the relay LCD, use the navigation menu:

SETTING MODE → **SYSTEM CONFIG** → **Date**

SETTING MODE → **SYSTEM CONFIG** → **Time**

Setting Time-Synchronization Parameters

Enter the time synchronization settings of the 7SR10 relay using Reydisp software. You can have access to all settings and select to synchronize the device time with the PC time via Reydisp Evolution. You can only access some of the settings using the on-site operation panel while the 7SR10 relay is being operated.

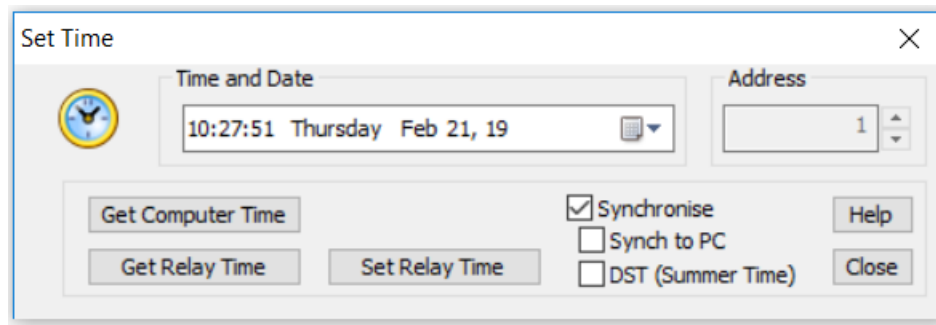

[sc_set_time, 1, --]

Figure 6-6 Set Time

In Reydisp Evolution, select **Relay** → **Control** → **Set Time and Date**.

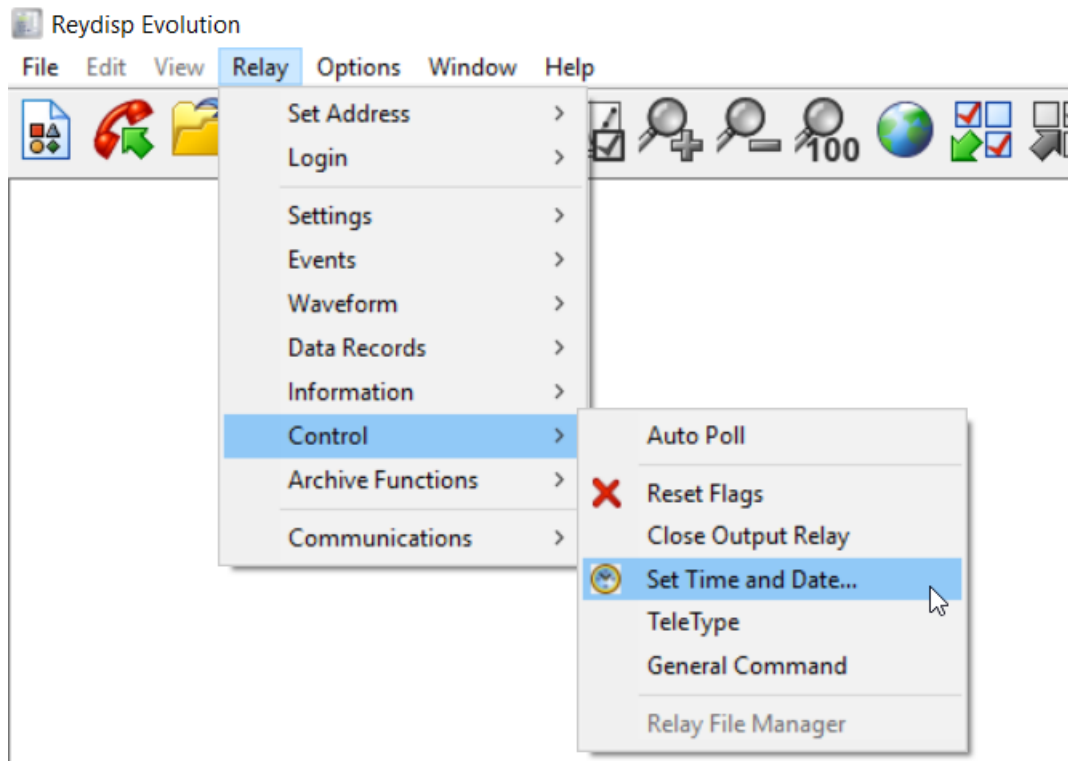

[sc_control_settime, 1, _-]

Figure 6-7 Set Time and Date

6.13 Settings Group

The relay provides 4 groups of settings – Group number (Gn) 1 to 2 for 7SR1003 and Group number (Gn) 1 to 4 for 7SR1004. At any time, only one group of settings can be active. From the relay LCD, you can assign group numbers by setting **SYSTEM CONFIG ▶ Active Group**.

It is possible to edit one group while the relay operates in accordance with settings from another **Active Group** using the setting **View/Edit Group**.

Some settings are independent of the active group setting, that is they are applicable to all settings groups. These groups are indicated on the top line of the relay LCD, where only the **Active Group No.** is identified. If settings are group-dependent, then it is indicated on the top line of the relay LCD both in **Active Group No.** and **View Group No.**

A change of the settings group can be achieved both locally at the relay LCD and remotely over the data communications channel or via a binary input. When using a binary input, an alternative settings group is selected only when the input is energized (**Select Grp Mode: Level triggered**) or latches into the selected group after energization of the input (**Select Grp Mode: Edge triggered**).

Settings are stored in a non-volatile memory.

6.14 User-Specific Curves

User-defined characteristic curves can be configured in the Reydisp software in the Curve Editor and added to the 7SR10 relay configuration. The user-defined curve appears as an extra option in the setting **Char** list. Using a specific name for user-defined curves in Reydisp software, these curves can be made applicable for all elements. The relay supports a maximum of 5 user-defined characteristic curves in a relay configuration. The name of the curve must be a maximum of 20 characters, consisting of the characters A-Z, a-z, 0-9, and space. For a more information about the Curve Editor, refer to the *7SR10 Engineering Guide*.

7 Commissioning

7.1	Overview	82
7.2	Test Suite Integrated in the Device	84

7.1 Overview

This chapter describes the commissioning of the 7SR10 relay. For an overview of the initial startup, refer to the [7.2.2 Initial Startup](#).

The commissioning and maintenance of this relay must only be carried out by qualified professional in protective-relay maintenance, capable of observing all the safety precautions and regulations appropriate to associated primary plant.

Various tests are to be performed for commissioning to warrant the correct function of the device.

Secondary tests can never replace primary tests because they cannot include connection faults. They provide a theoretical check of the setting values only. Primary tests are done only by electrically qualified personnel who are familiar with the commissioning of protection systems, with the operation of the system, and with safety regulations and provisions (for example: switching and grounding). Switching operations are to be performed for the commissioning. The described tests must be capable of being performed safely. They were not conceived for functional tests.

Inspection

Check that the device is not physically damaged.

Following must be checked before commissioning or maintenance actions:

- Relay ratings
- Operating instructions
- Installation instructions
- Terminal diagrams

The integrity of any protective ground conductor connection must be checked before carrying out any other actions.

Ensure that all connections are tight and correct to the wiring diagram and the scheme diagram in the *7SR10 Device Manual*. Check that the relay is the correct model and version and is correctly configured. Check that it is fully inserted into the case.

Ensure that the device is grounded from the grounding points correctly.

Hardware Tests

Operation of all inputs and outputs is tested in the factory. Tests can be repeated to check the device operation in its intended application.

The status indications of the respective binary inputs and binary outputs can be read from **Instruments** → **Binary I/O meters**.

Apply the required supply voltage onto each binary input in turn and check for correct operation.

The AC measuring accuracy is calibrated and tested in the factory but can be easily tested by checking values displayed by the instruments during secondary infeed as described.

The LEDs are tested in 3 ways:

- Pressing the key **Test/Reset**, so that the home screen of the relay LCD is displayed
- Energizing a suitably programmed binary input
- Sending an appropriate command over the data communication channel

Putting into Service

After tests have been performed satisfactorily, the 7SR10 relay must be put back into service as follows:

- Remove all test connections.
- Firmly tighten all screws. Tighten all terminal screws, including the ones that are not used.
- Replace all secondary circuit fuses and links, or close miniature circuit-breakers.

- Ensure that the **Prot. Healthy** LED (Protection Healthy LED) is on and glowing steadily. If necessary, press the push-button **CANCEL** until the screen **Relay Identifier** is displayed, then press the push-button **Test/Reset** to reset the indication LEDs for ≥ 3 s.
- Check the meters in the **Instruments Mode** with the relay on load.
- Download the complete configuration to a computer and store a copy for record of the settings produced. Compare the installed settings against the required settings supplied before testing began. Check if the protection, control, and auxiliary functions to be found with the configuration parameters are set correctly. You can download the settings from the device and compare them using the Reydisp software. The described tests are a guide for experienced personnel who can ensure tests are performed safely.

Routine Maintenance

The device does not require scheduled preventive maintenance although you can have periodic checking schedules to all protection devices. Operational checking can be limited to periodic visual checks of measured analog values at the device instruments. Check the data provided over the communication channels to supplement the continuous self-checking features of the device.

Repair

The device is designed with no user-serviceable parts. If a device reports a failure it can be returned to Siemens for investigation and repair. Contact and return details are provided by the local Siemens office. For more information, refer to [1.1 Unpacking, Repacking, Returning, and Storing](#).

Necessary precautions such as isolating the equipment, power supply, and connections must be applied before investigating further, particularly with respect to safety grounding.

7.2 Test Suite Integrated in the Device

7.2.1 Testing Protection Functions

The purpose of this test is to verify the correct setting of protection functions and the routing of signals. To do this, you can feed the test signals with test equipment. Digital test equipment offers you multiple test programs and test sequences.

7.2.2 Initial Startup

Establishing Readiness for Operation State

It is assumed that the steps in the chapters 1 to 4 are followed. Check the connection of the auxiliary power supply.

The 7SR10 relay has power supply ranges:

- AC 60 V to 240 V/ DC 60 V to 240 V, binary input threshold AC 44 V/DC 44 V
- AC 60 V to 240 V/ DC 60 V to 240 V, binary input threshold AC 88 V/DC 88 V
- DC 24 V to 60 V, binary input threshold DC 19 V
- DC 24 V to 240 V/AC 48 V to 240 V, binary input threshold AC/DC 19 V

Ensure that the correct auxiliary supply voltage and polarity is applied. Before making any connections, the device must be grounded. See the relevant wiring diagrams in the *7SR10 Device Manual* for the following relay terminals.

After successful testing of the voltage source, the device can be switched on.

Settings and Configuration

Select the required 7SR10 relay configuration and settings for the application. If more than 1 settings group is to be used for the application, then it is necessary to test both groups and also to test operation of the change mechanism.

If you use settings groups, it is important to remember that the relay might not be operating according to the settings that are currently displayed on the device screen. The setting **Active Group** on which the relay operates and the setting **View/Edit Group** are visible on the relay LCD and can be changed from the relay fascia push-buttons. The settings in one group can be altered from the relay fascia while the protection continues to operate on a different unaffected group. The setting **Active Group** and the setting **View/Edit Group** are selected in the menu **Configuration Device**.

The current **Active Group** and the group currently viewed are shown at the top of the relay LCD in the **Settings Mode**. If the **Active Group** is not shown at the top of the relay LCD, then it indicates that the setting is common to all groups.

CT/VT ratio, I/O mapping, and other settings which are directly related to hardware are common to all groups. If the relay is allowed to trip during testing, then the instruments display is interrupted and replaced by the screen **Trip Alert** which displays fault-data information. If the normal operation interferes with testing, then respective functions can be temporarily disabled for the testing duration with setting **Trip Alert** → **enabled/disabled** in the menu **Configuration Device**.

Instruments Mode from Relay LCD

The **Instruments Mode** shows measured or calculated values and some indications read from the 7SR10 relay. Measurement submenus display key quantities and information to aid with commissioning. You can navigate through the meters by using the push-buttons ▲ and ▼ dependent on the analog-input configuration of the device.

For more information on meters, refer to the [4.3.4 Instrument Mode](#).

The device instrumentation and metering provides real-time measured quantities and data, which is displayed on the relay LCD or via the data communications interface.

7.2.3 Precommissioning Tests

Secondary Tests

In the numerical relay test kits, select the appropriate burden (VA) for testing the 7SR10 relay functionalities. During testing, the following settings must be configured in the relay:

Parameters	Settings
Power frequency	Set rated frequency
CT/VT CONFIG	Set phase CT and ground ratio
FUNCTION CONFIG	Enable the protection to be tested
OUTPUT CONFIG	BO CONFIG → select (hand reset/self-reset) LED CONFIG → select (hand reset/self-reset)



NOTE

For automated overcurrent and earth-fault characteristics test modules

To reset the hand reset output contacts, assign the binary inputs to **Rst LED & O/Ps** and set the binary-inputs pickup delay as 0.5 s.

Primary Tests

A primary infeed is recommended to ensure the relay connections, CT polarity, and settings before implementing the protection scheme into service. Isolate the auxiliary DC supplies for alarm and tripping from the relay and remove the trip and inter-trip links.



NOTE

Before carrying out any primary infeed, it is important to ensure that appropriate current transformers are disconnected to avoid any maloperation of mesh corner or busbar type unit protection.

8 Device Maintenance

8.1	Self-Monitoring	88
8.2	Protection Healthy/Defective	90
8.3	Circuit-Breaker Maintenance	91
8.4	Periodic Maintenance	92
8.5	Troubleshooting	93
8.6	Replace and Return Defective Device	95
8.7	Firmware Upgrade and Loading	96

8.1 Self-Monitoring

The 7SR10 relay incorporates several self-monitoring features. Each of these features can initiate a controlled reset recovery sequence.

Supervision includes:

- Power-supply watchdog
- Code-execution watchdog
- Memory checks by checksum
- Processor/ADC health checks

These checks indicate that the relay is operating correctly and the LED **Prot. Healthy** is illuminated.

If an internal failure is detected, then a message is displayed on the relay LCD. The relay resets itself in an attempt to rectify the failure, which results in de-energization of any binary output mapped to protection healthy and resetting of the LED **Prot. Healthy**. If a successful reset is achieved by the relay, then the LED and the output contact returns to normal operating mode and the relay restarts, therefore ensuring the system is protected for the maximum time.

A startup counter meter is provided to display the number of startups that the relay has performed. Once the number of startups has exceeded a set number, an alarm output is triggered.

The counter can be reset from the meter, via a binary input, or via a command.

```
-----  
|Start Alarm      |  
|Count            1|  
|Target           100|  
|-----|
```

[dhw_startup-counter-meter, 1, en_US]

Figure 8-1 Startup Counter Meter

The following types of startup are monitored by the relay:

- **Power-on** starts
- **Expected starts** (user-initiated)
- **Unexpected starts** (caused by the relay watchdog)

Any combination of startup types can be selected for the startup count. If all the startup types are selected, then startups are added to the overall startup count.

– **MAINTENANCE MENU** → **START COUNT** → **Start Types**

The number of restarts can be set, before output alarm is raised.

– **MAINTENANCE MENU** → **START COUNT** → **Start Count Target**

When the number of relay startups reaches the target value, an output is raised, which can be programmed to any combination of binary outputs, LEDs, or virtual outputs.

– **OUTPUT MATRIX** → **Start Count Alarm**

Figure 8-2 shows the events which are generated when the relay restarts. The highlighted events show the cause of the restart. The event which comes next shows the type of restart followed by the relay: Cold and Power-on restart

To safeguard further, if the relay performs several unexpected starts in a given time, then you can configure **SYSTEM CONFIG** → **Unexpected Restart Period** using the setting **SYSTEM CONFIG** → **Unexpected Restart Blocking** to remove itself from service. In this case, the relay displays an error message as shown in *Figure 8-2*.

```
| UNEXPECTED RESTART |  
| COUNTS EXCEEDED! |  
| DEVICE LOCKED OUT |  
|                   |  
|-----|
```

[dw_unexpected-restarts-lockout-text, 1, en_US]

Figure 8-2 Unexpected Restarts Lockout Text

In the **Locked-up** mode, the relay disables the operation of

- All LEDs and binary outputs
- Prot. Healthy
- Push-buttons
- Data communications

and Once the relay has failed in this manner, it is non-recoverable at site and must be returned to Siemens for repair.

Miscellaneous Meters → **Unexpected Restarts** is provided to show how many unexpected restarts have occurred during the previous unexpected restart period. This is reconfigurable from the relay LCD.

8.2 Protection Healthy/Defective

If the relay is connected to auxiliary power supply and successfully passed its self-checking procedure, then the front fascia LED **Prot. Healthy** turns on.

A changeover or open contact can be mapped via the binary output matrix to provide an external protection healthy signal.

A changeover or closed contact can be mapped via the binary output matrix to provide an external protection defective signal. If the auxiliary power supply is not applied to the relay or a problem is detected within the relay, then the output contact closes to provide external indication.

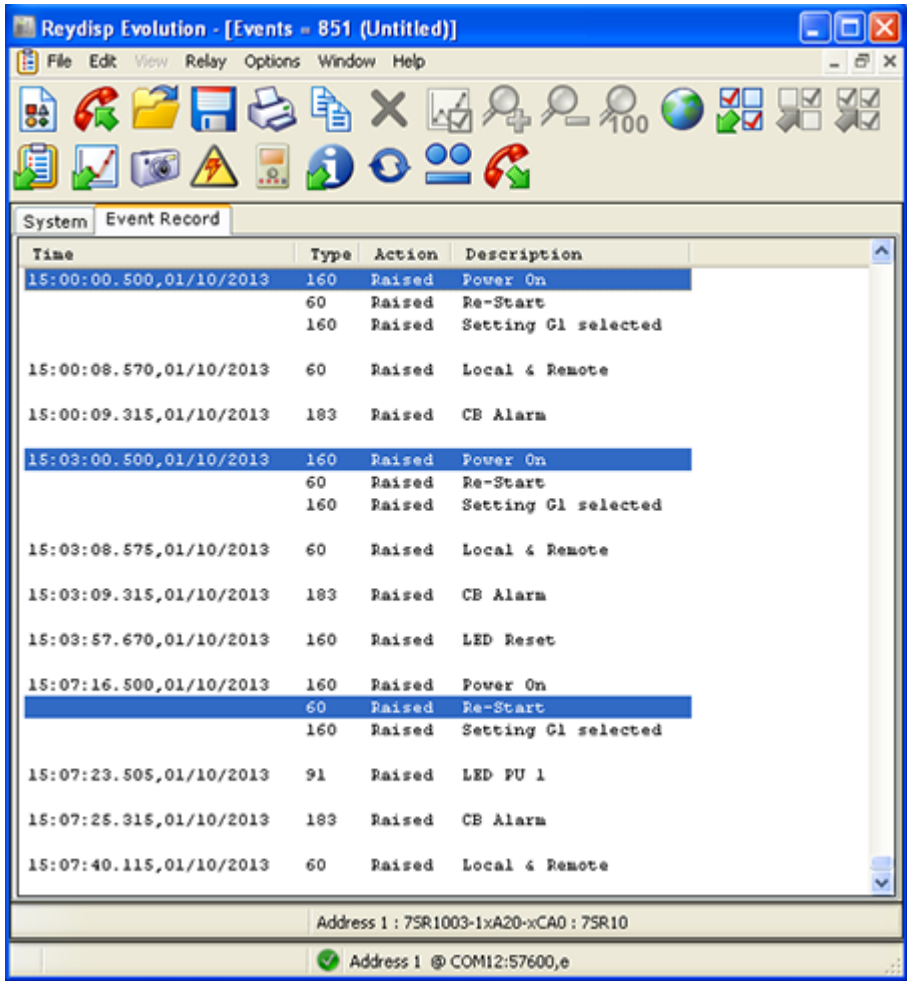

[sc_startupevents, 1, en_US]

Figure 8-3 Startup Events

8.3 Circuit-Breaker Maintenance

The relay provides **Total**, **Delta** and **Frequent CB Operation Counters**, and **I²t Counter** to estimate the amount of wear and tear experienced by a circuit breaker. The alarm is triggered once the set levels have been exceeded. Typically estimates obtained from previous circuit-breaker maintenance schedules or manufacturers data sheets are used for setting these alarm levels. The relay instrumentation provides the current values of these counters.

8.3.1 CB Counters

CB Maintenance Counters	Description
CB Total Trip Count	Increments on each trip command issued
CB Total Trip Manual Open	Selects whether the CB Total Trip Counter is incremented for Manual Open operations. If disabled, then CB Total Trip Counter will only increment for protection trip commands.
CB Delta Trip Count	Additional counter which can be reset independently of the Total Trip Count . For example, this counter is used for recording trip operations between substation visits.
CB Delta Trip Manual Open	Selects whether the CB Delta Trip Counter is incremented for Manual Open operations. If disabled, then CB Delta Trip Count will only increment for protection trip commands.
CB Count to AR Block: (Only in Auto-reclose models)	Displays the number of CB trips experienced by the CB before the AR is blocked. When the target is reached the relay will only do 1 Delayed Trip to Lock out . An output is available to reset this value.
CB Count to AR Block Manual Open: (Only in Auto-reclose models)	Selects whether the CB Count to AR Block is incremented for Manual Open operations. If disabled, then CB Count to AR Block will only increment for protection trip commands.
CB Frequent Ops Count	Logs the number of trip operations in a rolling window period of 1 hr. An output is available to reset the counter.

Binary outputs can be mapped to each of the counters and outputs are energized when **Count Target** or **Alarm Limit** is reached.

8.3.2 I²t CB Wear

The I²t counter provides an estimation of contact wear and maintenance requirements. The algorithm works on a per phase basis, measuring the arcing current during faults. The I²t value at the time of trip is added to the previously stored value and an alarm is given when any one of the 3-phase running counts exceeds the set alarm limit. The **t** value is the time between CB contacts separation, when an arc is formed between separation time and the CB break time.

The I²t value is triggered and reset from a binary input or command.

8.4 Periodic Maintenance

The device does not require scheduled preventative maintenance although you can apply periodic checking schedules to all protection devices. Operational checking can be limited to periodic visual checks of measured analog values at the device instruments or the data provided over the communication channels to supplement the continuous self-checking features of the device.

The device incorporates several self-monitoring features. Since the device is self-monitoring, hardware and software errors are automatically forwarded. This action minimizes any down time of the device. It also eliminates the need for frequent maintenance inspections.

8.5 Troubleshooting

This section provides the common problems and the recommended solution to resolve the problem.

Observation	Action
Relay does not power up	Check that the correct auxiliary AC or DC voltage is applied and the polarity is correct.
Relay is not accepting the password	The password entered is wrong. Enter the correct password. If you have forgotten the correct password, note down the numerical code displayed on the Change Password screen. For example, Change password = 1234567 To retrieve the password, communicate the numerical code to a Siemens customer support center representative.
Protection Healthy LED flashes/reset	General failure. Contact the Siemens customer support center representative.
LCD screen flashes continuously	The LCD displays multiple error messages by flashing continuously. Indication of various processor card faults. General failure. Contact the Siemens customer support center representative.
Relay displays one instrument after another without user intervention	This is normal operation, the default instruments are enabled. Remove all instruments from the default list and add only the instruments that are required.
Unable to upload the waveform using Reydisp Evolution	Reydisp evolution version 9.83 must be used from firmware 2437H80001R4m-2h and higher.
Cannot communicate with the relay	<ul style="list-style-type: none"> • Check that all the communication settings match with the settings used by Reydisp Evolution/Manager. • Check that all cables and modems are working correctly. • Ensure that IEC 60870-5-103 is specified for the connected port (COM1 or COM2).
Relays are not communicating in a ring network	<ul style="list-style-type: none"> • Check that all relays are powered up. • Check that all relays have unique addresses. • Verify the rear connection of each device as mentioned in the terminal diagram.
Status inputs do not work	<ul style="list-style-type: none"> • Check that the correct DC voltage is applied and that the polarity is correct • Check that the status input settings such as the pickup/drop-off timers and the status inversion function are correctly set • For AFD function, refer to the 7XG31xx documentation for further details.
Device USB port is not communicating with Reydisp evolution	Perform the cold start and connect the relay with Reydisp evolution. By performing cold start the device settings are defaulted and the user data will be erased. It is recommended to note down the settings before performing cold start.
Relay instrument displays show small currents or voltages even though the system is dead	This is normal. The relay is displaying calculation noise. This does not affect any accuracy claims for the relay.

Observation	Action
Firmware update	Siemens recommends restarting the relay once the firmware update is completed.
Voltage and current phase angle measurement is not correct in the relay	Refer to the 7SR10 Overcurrent relay terminal diagram. Connect start and stop points of CT and VT as mentioned in the terminal diagram. Start point is mentioned with dot mark in the terminal diagram.

8.6 Replace and Return Defective Device

8.6.1 Error Backup Device

If you cannot correct a defect reported by the device, you can replace this device with a backup device. The backup device is configured with available project data from Reydisp Manager. Once the device has failed in this manner, it is non-recoverable at site and must be returned to the manufacturer for repair. The relay must be returned as a complete unit. No attempt must be made to disassemble the unit to isolate and return only the damaged subassembly.

8.6.2 Replacing a Device

- ✧ Take the device out of operation.
- ✧ Remove the wired terminal blocks from the module to be exchanged or alternatively all connections from the device.
- ✧ Remove the device and fitting parts.

Installing a Replacement Device

- ✧ If needed, assemble the replacement device.
- ✧ Put the device back into operation.

8.6.3 Returning a Device

When returning a device, proceed as follows:

- ✧ Ensure that the devices are either shipped with the original packaging or with the designated transport safety casings.
- ✧ Protect the optical interfaces on the communication or arc-protection modules against the ingress of dust. Use, for example, the protective covers provided in the delivery condition.
- ✧ Pack the defective device (base module and expansion module) or the complete device.
- ✧ Return the defective device to your Siemens local office or sales partner.



NOTE

If the device is incomplete, for example if terminals are missing, it cannot be taken back.

8.7 Firmware Upgrade and Loading

8.7.1 Guidelines

Before proceeding with firmware (software) download/upgrade, observe the following guidelines:

- The following guidelines are compatible with Microsoft Windows XP SP2 or later, Windows Vista, Windows 7, Windows 8, and Windows 10.
- Ensure the PC that you use to install the firmware to the 7SR10 relay has the necessary USB driver installed. For more information, refer to the *7SR10 Engineering Guide*.
- Search and download the latest **Reyrolle Argus 7SR10 Overcurrent & Earth Fault Protection** firmware from the SIOS Internet page <https://support.industry.siemens.com/cs/start?lc=en-WW>. Log on is required to download the firmware.
- If the firmware was sent as an attachment to an e-mail from Siemens customer care, then the file is a password protected self-extracting zip file to prevent e-mail systems discarding them or modifying them. The software must be saved with the extension **EX** renamed to **EXE**. The password that is applied to this zip file is REYROLLE in upper-case letters.

8.7.2 Firmware Upgrade in Relay Installed On-site

If you are upgrading firmware in the relay that is already installed on-site, then follow the procedure in this section. Otherwise, skip directly to [8.7.3 Firmware Loading in New Relay](#).

- ✧ Identify which firmware is loaded in the 7SR10 relay.
- ✧ With the relay connected to a suitable auxiliary power supply, press **CANCEL** several times to ensure that you are at the root of the menu system. The relay typically displays the relay model name or the circuit name.
- ✧ Press push-buttons **CANCEL** and **TEST** simultaneously to bring up the menu **SOFTWARE VERSION**.

The following typical information uniquely identifies a particular relay model:

Table 8-1 Overall Software Information

Software Art No	The application software code used, which is common to many relay variants
Build Date	The date when the software was compiled
Build Time	The time when the software was compiled
Code CRC	The CRC check code of the software code
Boot Block Art No	The boot block software code responsible for loading in new application software code

Table 8-2 Product-Configuration Information

Product Art No	The products unique configuration article number
Product Name	The products unique model name
Release Date	The date when a particular configuration was released
Release Time	The time when a particular configuration was released

To Do List Before Loading New Firmware

- ✧ Take a hard copy or download all relay settings groups, communication settings, and language settings before upgrading the firmware. Otherwise, all settings are lost during the upgrade process.
- ✧ It is possible to download the existing settings from Reydisp software and then reload these settings into the relay. For more details, refer to the *7SR10 Engineering Guide*.

- ✧ The Reydisp software highlights the changes which are not resolved automatically. The software allows you to manually correct the settings. The tools **Communications Editor** and **Language Editor** are used to download/upload these settings.
- ✧ If the relay is in service, then it is advisable to remove any **TRIP LINKS** to prevent inadvertent mal-operation due to incorrect settings being applied.
- ✧ If the settings password is set in the relay, then it must be disabled by setting it to **NONE**.
- ✧ Proceed to complete the procedure mentioned in [8.7.3 Firmware Loading in New Relay](#).

To Do List After Loading New Firmware

If the relay communication ports are required for data communication, then you have to configure the settings. Navigate to the menu **relay communications** and manually configure the communication settings. For example: station address, IEC870 port selection, baud rate, and parity.

- ✧ **Acknowledge default settings screen**

After the firmware upgrade, the relay settings are automatically configured to default factory settings. Once the relay reboots, the relay LCD shows a flashing message as shown in [Figure 8-4](#). Acknowledge the message screen by push-button **ENTER** on the device front fascia, before reloading/re-entering the customized settings.



[sc_7sr10_fui_step5, 1, _...]

Figure 8-4 Settings Defaulted on Relay LCD

- ✧ **Settings**

- If necessary, reload or re-enter all customized settings, communication and language settings, and verify that all settings are correct.
- If necessary, use the communications editor to reload any communications configuration files previously saved.
- If necessary, use the language editor to reload any language files previously saved.

- ✧ **Trip Links**

Reinsert any TRIP Links that are removed initially.

Known Problems and Work Around

On Windows XP systems, executable files attached to e-mails are blocked from execution.

- ✧ If the following message occurs, then the solution is to access the .exe file properties. Right-click the file and select **Properties** > **General** > **Unblock** > **Apply** > **OK**. Unblocking allows the file to be executable.



[sc_7sr10_fui_step7, 1, _...]

Figure 8-5 Message in Windows XP Systems

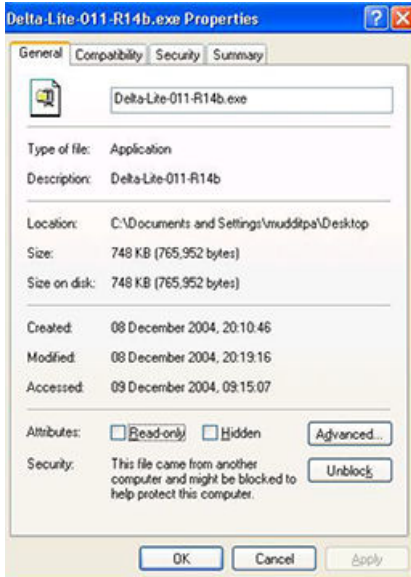

[sc_7sr10_fui_step6, 1, ...]

Figure 8-6 Properties Unlocking

Error Messages

Incompatible MLFB Error Box

- The incompatible MLFB error dialog (Figure 8-7) is displayed when the code loader package does not contain suitable firmware for the device. If errors persists, then check the following points:

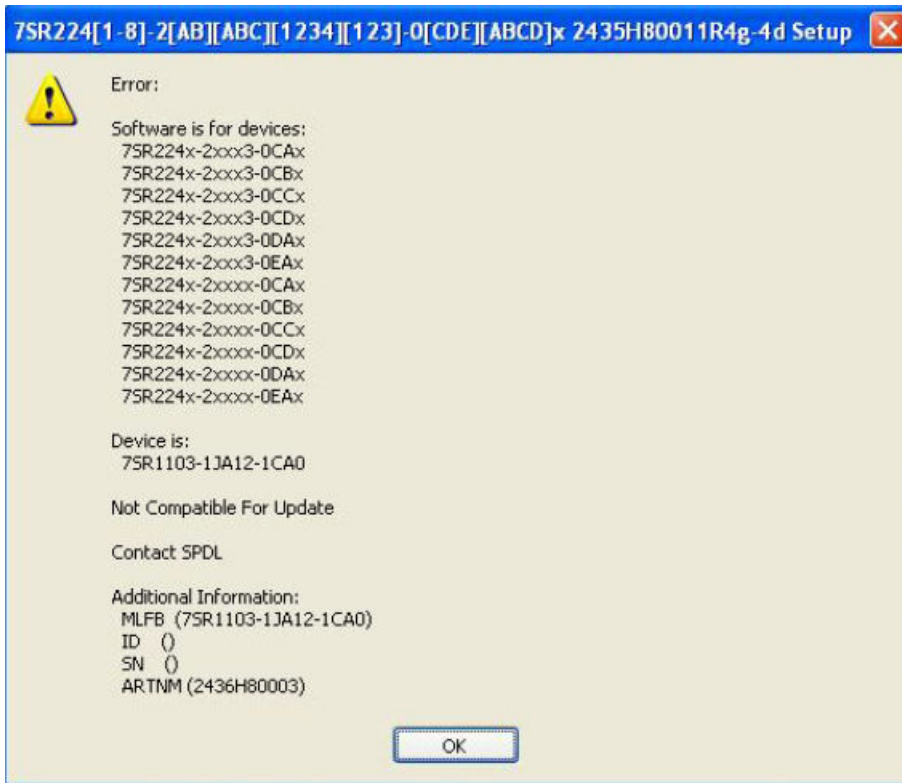

[sc_7sr10_fui_step8, 1, ...]

Figure 8-7 Incompatible MLFB Error Dialog

- ✧ Ensure that the code loader package is correct for the relay MLFB. The detected MLFB of the relay is shown in the MLFB field of the error dialog. If the package is incorrect, obtain the correct code and upload package for the device.
- ✧ Ensure that the relay MLFB is detected correctly. The MLFB field in the error dialog is expected for this type of device. If MLFB is empty, contact the Siemens customer care as to why it is not set!

Auto-Detect MLFB Fails (Error Code = 3)

- ✧ If the auto-detection of the MLFB fails and shows an error code as shown in [Figure 8-8](#), then the installation process continues and provides a list of MLFB options ([Figure 8-9](#) and [Figure 8-10](#)) available in the upload package.



[sc_7sr10_ful_step9, 1, -,-]

Figure 8-8 Error Code = 3 Pop-up

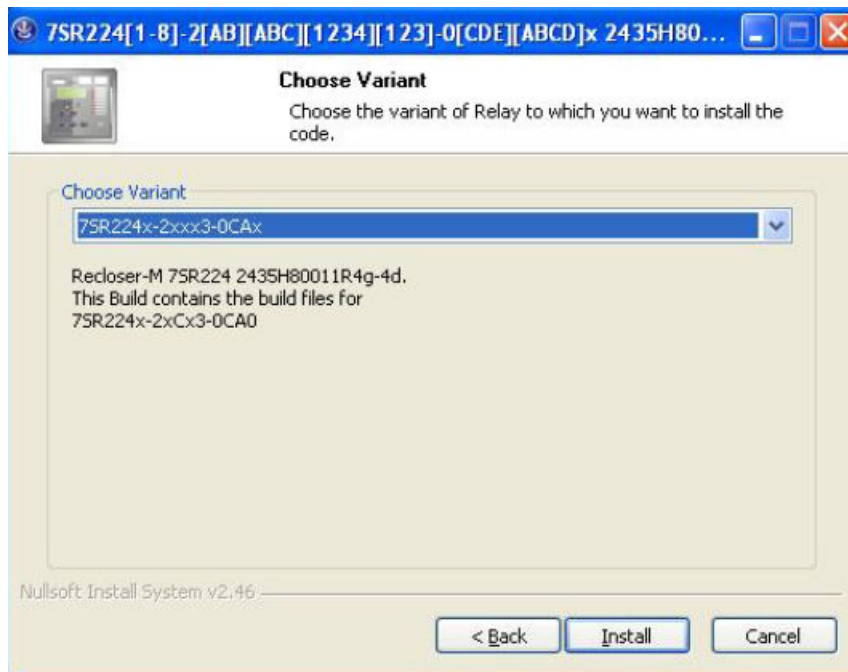

[sc_7sr10_ful_step10, 1, -,-]

Figure 8-9 Select Variant Dialog

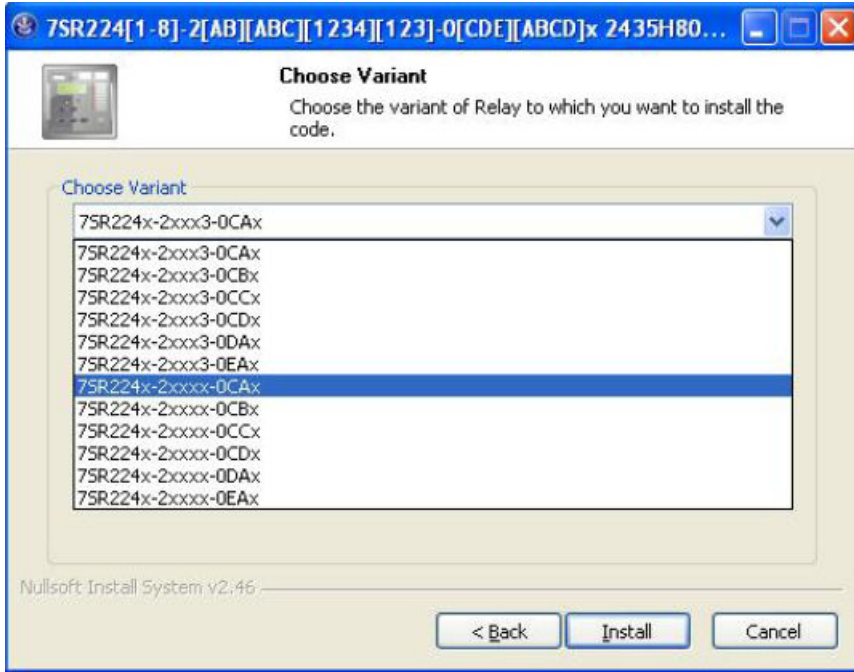

[sc_7sr10_fui_step11, 1, ...]
Figure 8-10 List of Available MLFBs

Select the correct MLFB of the relay. Failure to do this result in the device not starting. Rectify by loading a correct firmware for a respective MLFB.



NOTE
From the list box of MLFBs, the number marked with x can be ignored.

Firmware Upgrade Failure

- ✦ If the device firmware upgrade fails in the middle of an upgrade process where some of the firmware component files fail to load in the device, an error message appears on relay LCD. Restart the firmware upgrade process and make sure that firmware is updated successfully.



[sc_7sr10_fui_step12, 1, ...]

8.7.3 Firmware Loading in New Relay



NOTE
This procedure is supported on the latest relays. If you have an older relay or encounter problems with this procedure, refer to [8.7.4 Firmware Loading in Old Relays](#).

New firmware can be loaded via the USB port on the front fascia.

- ✦ To load the firmware, connect a USB cable between the PC and the USB port on the front of the relay.

- ✧ Apply auxiliary power supply to the relay. Wait for the relay to complete its boot sequence.
- ✧ Run the appropriate code loader package for the device. The code loader displays the dialog **Interrogating Relay** to detect the type of relay and the firmware to apply. Once detected, the code loader displays a title page as shown in [Figure 8-11](#). Click **Next**.

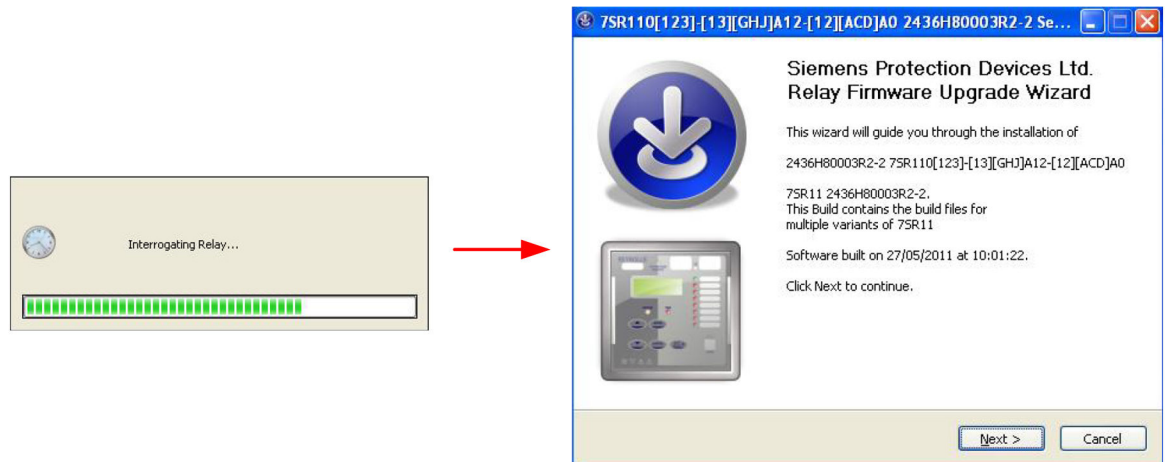

[dw_7sr10_fui_step1, 1, --]

Figure 8-11 Interrogating Relay and Title Page



NOTE

If an error message is displayed without title page, then refer to [8.7.2 Firmware Upgrade in Relay Installed On-site](#).

- ✧ The license page is displayed, select **I accept the terms of the License Agreement** and click **Next**.

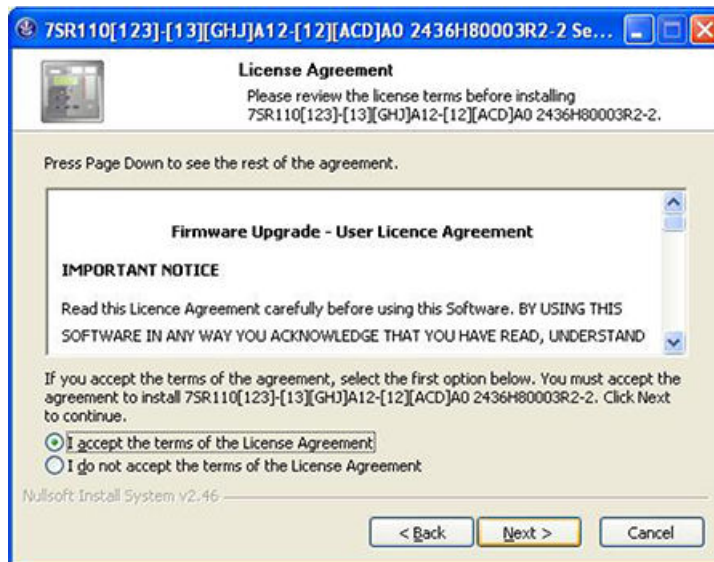

[sc_7sr10_fui_step2, 1, --]

Figure 8-12 License Agreement Dialog

- ✧ The dialog **Reyfresh for Windows** opens and a timing bar can be seen to be counting down at the bottom of the window. After a few seconds, the update automatically begins.

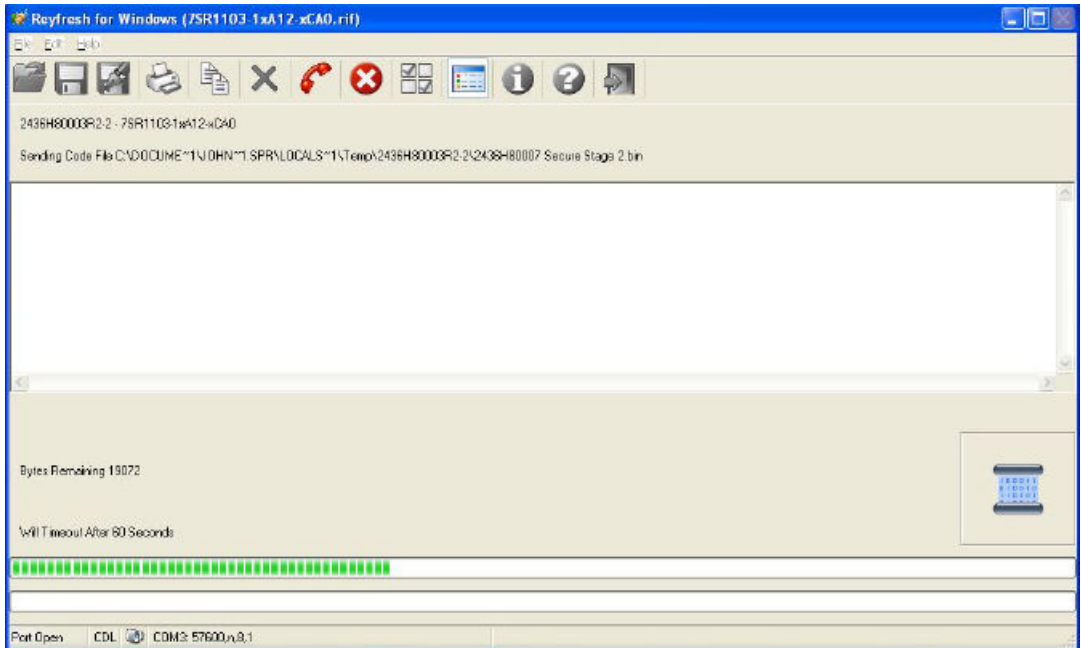

[sc_7sr10_ful_step3, 1, -_-]
Figure 8-13 REYFRESH Window

- ✧ The process takes several minutes to automatically restart the relay. Make note of any warning or error messages that appear on the REYFRESH terminal window as the relay restarts. Do not attempt to use the PC or laptop computer when the firmware is loading, as this can disrupt the code load process. Once restarted, close the REYFRESH window. Then, click **Finish** to close the code loader.

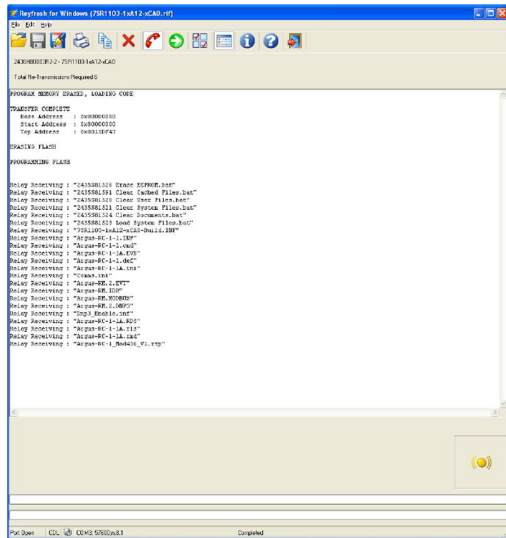

[ldw_7sr10_ful_step4, 1, -_-]
Figure 8-14 Firmware Installation Success

8.7.4 Firmware Loading in Old Relays

- New firmware can be loaded via the USB port on the front fascia. To load the firmware, connect a USB cable between the PC and the USB port on the front of the relay.
- The relay accepts new firmware during restart. The easiest way to do is to remove the auxiliary power supply.
- ✧ Remove the auxiliary power supply.

- ◇ Run an appropriate code loader program for the relay.
- ◇ Wait for the dialog **Reyfresh for Windows** to open and a timing bar can be seen to be counting down at the bottom of the window.
If the download does not automatically start, then press the PLAY button ►.

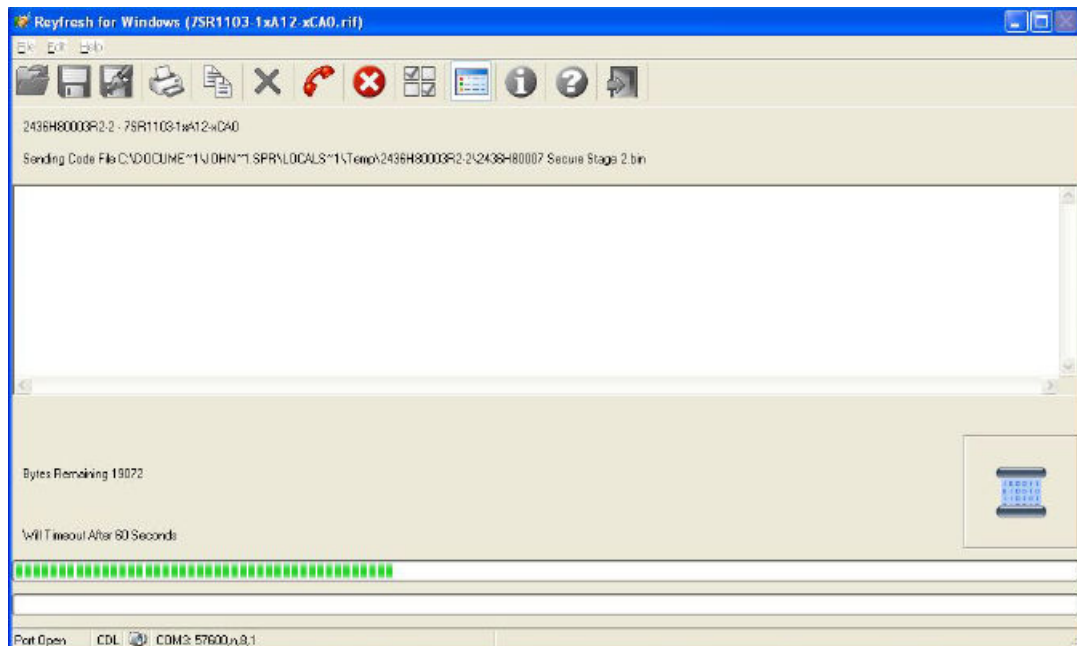

[sc 7sr10_fui_step3, 1, -_-]
Figure 8-15 Reyfresh Window



NOTE

The next step must occur before the green timing bar expires.

- ◇ Press and hold-up the arrow key on the keyboard.
- ◇ Restart the relay by reapplying the auxiliary power supply.
- ◇ Release the arrow key. The software upload process must now proceed.
- ◇ If any warning or error messages appear on the window **Reyfresh**, then the relay restarts. If you failed to reapply the auxiliary power supply quickly enough, the **Reyfresh** fails its initial handshake and you must repeat the firmware loading.
- ◇ If you do not wish to remove the auxiliary power supply, then follow this step:
To disconnect its auxiliary power supply, withdraw slightly the relay from its case. To prepare the relay for firmware download, press push-button ▲ and reinsert relay into its case.

Solving Firmware Upgrade Problems

- ◇ The relay auto-detects the download baud rate and uses whatever baud rate set within **Reyfresh**. However the default and maximum baud rate of 460 800 bits/s is preferred.
- ◇ The download procedure has been tested on Microsoft Windows XP SP2 or later, Windows Vista, Windows 7, Windows 8, and Window 10.
- ◇ On Windows 98, it is necessary to add the following line to the file **C:\CONFIG.SYS** to increase the environment space.
Shell=C:\COMMAND.COM C:\e:4056 /p

- ✧ When the relay restarts, a message appears on the LCD to confirm the number of I/O modules fitted. Press the **ENTER** key when requested when the details displayed are correct.

9 Security Settings

9.1	Confirmation ID (Password Feature)	106
-----	------------------------------------	-----

9.1 Confirmation ID (Password Feature)

The relay incorporates 2 levels of confirmation IDs - one for settings and other for control functions.

A confirmation ID (shown as **Password** in the device LCD display) serves to prevent you from carrying out critical operations inadvertently. By entering the confirmation ID for settings and control functions, the chances of performing operations inadvertently with potentially failure-inducing effects are reduced.

The programmable confirmation ID feature enables the user to enter a 4-character alphanumeric code to perform setting changes and control functions in the relay. The confirmation ID in factory-supplied relay is set to **NONE**, that is, the confirmation ID feature is disabled. The confirmation ID must be entered twice as a measure against accidental changes. Once a confirmation ID is entered, then it is required thereafter to change the settings or initiate control commands. Confirmation IDs can be deactivated using the confirmation ID to gain access and by setting the confirmation ID to **NONE**. To deactivate the confirmation ID feature, enter the confirmation ID twice.

As soon as the you attempt to change a setting or initiate control, the confirmation ID is requested before any changes are allowed. Once the confirmation ID has been validated, the user is not prompted for the confirmation ID for the next 1 hour. If no more changes are made within 1 hour, then the confirmation ID prompts are automatically activated.

The setting confirmation ID is a confirmation mechanism to prevent inadvertent changes to settings from the front fascia or over the rear serial communication channel(s). The control confirmation ID is a confirmation mechanism to prevent the inadvertent operation of control operations and commands from the menu **Control** on the relay fascia.

The confirmation ID validation screen also displays a numerical code. If you have lost or forgotten the confirmation ID, you can communicate this code to the Siemens customer support representatives and the confirmation ID can be retrieved.



NOTE

The default control confirmation ID is **AAAA**. Siemens recommends changing the default confirmation ID after the final configuration.

A Firmware and Hardware Revision History

A.1	Revision History	108
-----	------------------	-----

A.1 Revision History

Firmware 7SR1002/7SR1003

Year/Month	Firmware Version	Description of Change
2024/06	2437H80001R5d-2k	Firmware maintenance
2023/10	2437H80001R5c-2j	Firmware maintenance
2022/04	2437H80001R5a-2i	Firmware maintenance
2021/07	2437H80001R4m-2h	Support for new hardware variant and firmware maintenance
2021/02	2437H80001R4l-2g	Addition of functions & firmware maintenance
2020/11	2437H80001R4k-2g	Firmware maintenance
2019/12	2437H80001R4k-2f	Firmware maintenance
2019/01	2437H80001R4j-2e	Firmware maintenance
2018/05	2437H80001R4h-2d	Firmware maintenance
2017/09	2437H80001R4d-2c	Data communications improvements
2017/04	2437H80001R4c-2b	Minor modification in analog
2016/11	2437H80001R4b-2b	Support for Reydisp Manager tool
2015/09	2437H80001R4b-2a	Addition of AR variants
2015/06	2437H80001R4b-1f	81THD function added
2015/03	2437H80001R4b-1e	Addition of non-directional SEF device variants
2015/02	2437H80001R4b-1d	First maintenance
2013/11	2436H80015R2d-1a	First release

Firmware 7SR1004

Year/Month	Firmware Version	Description of Change
2024/06	2437H80008R5d-1h	Firmware maintenance
2023/10	2437H80008R5c-1g	Firmware maintenance
2022/07	2437H80008R5b-1g	Firmware maintenance
2022/02	2437H80008R4n-1f	Firmware maintenance
2021/09	2437H80008R4m-1e	Fault recorder upgraded
2020/11	2437H80008R4k-1d	Firmware maintenance
2020/03	2437H80008R4k-1c	Addition of Directional Sensitive Earth Fault (67SEF) – Measured 3V0/I0-Φ
2019/12	2437H80008R4j-1c	Firmware maintenance
2019/05	2437H80008R4j-1b	50AFD, 50LC, ITHD, Watt-metric functions added
2018/06	2437H80008R4h-1a	First release

Hardware 7SR1002/7SR1003

Year/Month	Hardware Version	Description of Change
2022/04	7SR10/EE	Fourth release (Addition of 3 BI, 3 BO variant)
2021/08		Third release (Addition of new power-supply variant)
2019/08		Second release
2015/01	7SR10/DD	First release

Hardware 7SR1004

Year/Month	Hardware Version	Description of Change
2019/08	7SR10/EE	Second release
2018/07	7SR10/DD	First release

Index

1,2,3 ...

2nd Harmonic Current 47

A

Active Energy 48
AFD meters 50
Autoreclose meters 50, 50

C

Calc Earth Voltages 48
CB counters 91
Change device settings 77
Checking the rated data and functions 14
Commissioning 82
Confirmation ID 106
Connecting a device 15
Connecting devices 21
Control mode 43, 75
Current meters 46

D

Data storage 69
Displaying indications 65
Drilling patterns and device dimensions 18

E

Electrical inspection 15
Energy Meters 48, 49, 49
Error backup device 95

F

Fault data mode 43, 54
Favorite meters 46

Firmware loading 96
Firmware upgrade 96
Follow-up inspection on a device 14
Frequency meters 50

G

General Alarm Meters 51
Grounding the devices 21

I

I Seq Components 46
I2t CB wear 91
Incoming inspection 14
Installing devices 20
Instrument mode 43, 45

L

Last Trip E/F 47
Last Trip P/F 47
Last Trip Voltage 48

M

Metering 73
Mounting instructions 19

N

Nom Earth current 46
Nominal current 46
Nominal Ph-N Voltage 47
Nominal Ph-Ph Voltage 47

O

Operating concept 38
Operating mode 74
Operator and display elements 39

P

Performing the electrical inspection 16
Power Meters 48
Pri Earth current 46
Pri Ph-N Voltage 47
Pri Ph-Ph Voltage 47
Primary current 46
Protection healthy 90

R

Reactive Energy 49
Real-time clock 76
Recommended terminal-lugs specifications 22
Relay menu 43
Repacking a device 12
Replacement of the device 35
Replacing a device 95
Returning a device 95

S

Safety notes 63
Sec Earth current 46
Sec Ph-N Voltage 47
Sec Ph-Ph Voltage 47
Secondary current 46
SEF 3V0/I0 METERS 49
Self-monitoring 88
Setting mode 43, 45
Settings group 79
Storing a device 12

T

THD meters 49
Thermal meters 49
Troubleshooting 93

U

Unpacking a device 12

User-interface operation 44
User-specific curves 80

V

V Seq Components 47
Voltage meters 47