

AUXILIARY | TRIPPING | SUPERVISION

Delta XRD

Compact high-performance supervision relays for power utility protection and control applications.

- > Trip supply supervision
- > Trip circuit supervision
- > Supervision HEALTHY green LED
- > Hand reset alarm flag
- > Optional self-reset red alarm LED
- > Surface or rail mount
- > Flush panel or rack mount
- > Made in Australia





Features

- > High visibility electro-mechanical flag indication drops to indicate supervision alarm condition
- > Optional low cost red LED alarm indication
- > Supervision Healthy LED
- > Two, three or four C/O alarm contacts
- > Rated operate voltages available for 24, 30/32, 48, 110, 125, 220, 240 or 250 Volts DC nominal auxiliary supplies
- > Panel, rack or rail mount options
- > Compact size 2, 2U high case
- > Plug-in terminal block
- > M4 screw terminals

Model Designation

DELTA XRD MODELS:

- > XRD-4 Trip supply supervision with hand-reset mechanical flag alarm indication
- > XRD-5 Trip supply supervision with self-reset LED alarm indication
- > XRD-6 Trip circuit supervision with hand reset mechanical flag alarm indication
- > XRD-7 Trip circuit supervision with self-reset LED alarm indication

Application

The Delta XR Series Relays are low burden electro-mechanical supervision relays for application on high security tripping and auxiliary supply circuits.

The Delta XR relays have been designed to provide a balance of low burden to minimize the possibility of circuit breaker mal-operation while maintaining a minimum contact whetting current to avoid nuisance alarm conditions.

A key feature of the design is a high visibility mechanical flag indicator that can only be reset under healthy supervision conditions. Versions with a self-reset alarm LED may be selected as a lower cost option. A green Healthy LED is standard. Failure of the circuit or supply being supervised will cause the main relay element to drop out, an alarm signalled via the flag or red LED and the alarm contacts to change state.

A wide voltage range and standard hand reset flag reduces the number of model variations. The Delta range is packaged in a size 2, 2U high case that may be flush panel, rack or rail mounted.

A plug in terminal block is provided to allow panel pre-wiring.

Front Panel Layout

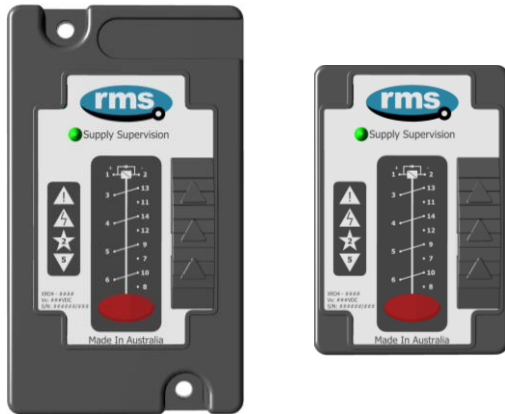
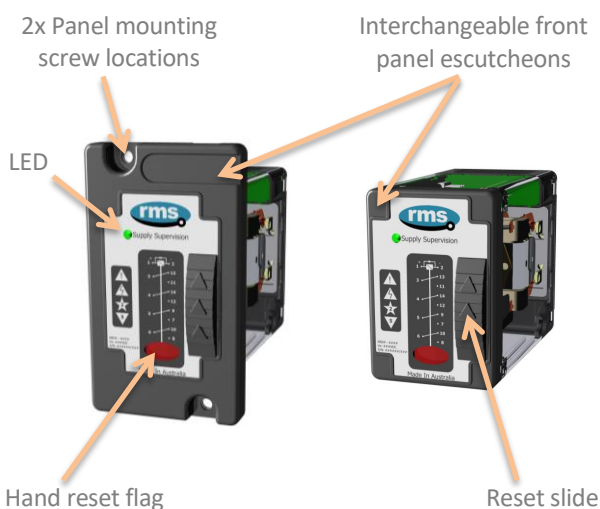

Figure: 1: XRD front panel
Left – Panel mount Right – rail mount

Front Panel Configuration

Delta relays can be easily converted from a rail mount to a flush mount configuration. This is achieved by un-clipping the front rail mount escutcheon, securing a metal panel mount plate with four (4) screws and clipping on a panel mount escutcheon. This process may be reversed to convert from a panel mount to a rail mount version.

Delta relays may be ordered with the desired configuration or converted by the user using one of the conversion kits listed in the ordering section.



Supervision Healthy LED

A front panel green LED is provided to indicate when the supervised circuit is HEALTHY.

Alarm Contacts

All contacts operate (Pick-up), when the monitored circuit is in the HEALTHY condition. FAILURE of the supervision circuit will cause the alarm contacts to drop out.

Hand Reset Flag

A high visibility mechanical flag drops when the supervised circuit status changes from the HEALTHY to the FAIL condition. The flag can only be manually hand reset using the front panel reset slide after the supervision fail condition has been corrected.

Self-Reset Red LED Flag (XRD-5 and XRD-7 only)

A red LED is illuminated when the supervised circuit status changes from the HEALTHY to the FAIL condition. The LED will automatically extinguish after the supervision fail condition has been corrected. The front panel slide switch and mechanical flag is not fitted to XRD-5 and XRD-7 variants.

Nominal Operating Voltages

24, 32, 48, 110, 125, 220, 240 and 250V DC available.

Terminal Block

TBD-R1 /R2	Rear connect terminal block Suitable for flush mount relay version
TBD-F	Front connect terminal block Suitable for rail mount relay version

Description

The XRD-4 is designed to supervise the DC auxiliary supply employed on high security protection and tripping circuits employed in high voltage power systems. The XRD-4 comprises a heavy-duty attracted armature control relay with a single operating coil and delay slug.

Under healthy conditions, the coil is energized and if the supply fails, the relay will drop out to initiate a supply fail alarm. A time delay is incorporated to avoid nuisance tripping due to switching transients.

Supervision Circuit Burden

The XRD-4 circuit design is optimized to minimize the supervision current to minimize the burden on the supervised DC supply. The maximum XRD-4 burdens are as follows:

Nominal	Healthy
24V	4.0W
32V	5.0W
48V	4.5W
110V	4.5W
125V	4.5W
220V	5.5W
240V	6.0W
250V	6.0W

Thermal Rating

All circuits are designed to withstand continuous application of 120% of nominal voltage.

Operating Voltage Range

70% to 120% of nominal continuous at 25 degrees Celsius

Drop-out Voltage

The highest voltage level at which the relay will drop out and signal an alarm is 70% of nominal.

The lowest voltage level at which the relay will remain picked up is 60% of nominal. Below 60% of nominal an alarm signal condition is guaranteed.

Drop-out Time

300 to 600ms at 25 degrees Celsius

Reset

When the supervision fault is rectified the contacts will self-reset to the picked up healthy state. The mechanical flag indicator must be hand reset.

Normal Operating Conditions

AUXILIARY SUPPLY AVAILABLE

Figure 5 shows a typical DC auxiliary supply circuit with the XRD-4 employed to supervise the auxiliary supply. The blue lines depict the supervised circuits and red arrows depict the path of the supervision current with a healthy auxiliary supply applied.

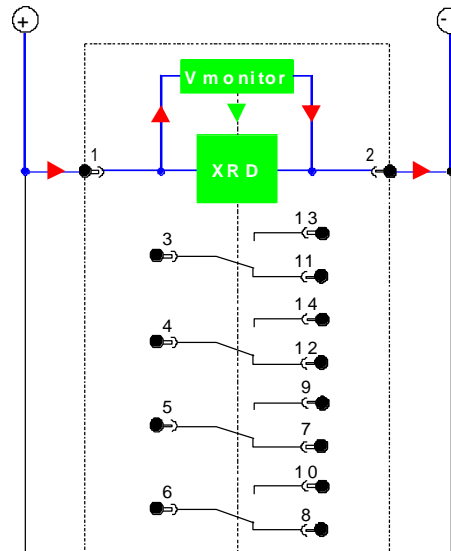

Figure 5: Delta XRD-4 - Normal system condition

Abnormal Operating Condition

AUXILIARY SUPPLY FAIL – ALARM CONDITION

Figure 6 shows the XRD-4 supervision relay dropped out due to the loss of auxiliary supply. Loss of the supervision current due to a loss of the auxiliary supply for <300ms will not cause this condition. Loss of supply will cause the green HEALTHY LED to be extinguished.

An alarm is reported through the change in state of the four (4) alarm contacts and the front panel hand reset flag indicator.

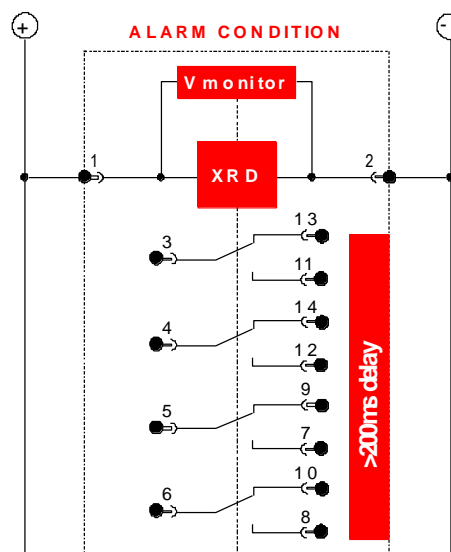

Figure 6: Delta XRD-4 - Abnormal condition – Loss of supply

Description

The XRD-5 provides similar functionality to the XRD-4 described in the previous section. For technical details not found in this section, reference should be made to the XRD-4 data. Technical data specific to the XRD-5 are as follows:

Alarm Signalling

- > 2 C/O alarm contacts
- > Self-reset red alarm LED

Normal Operating Conditions

AUXILIARY SUPPLY AVAILABLE

Normal operating condition is indicated on the front panel via a green LED and the alarm contact being picked up.

Abnormal Operating Condition

AUXILIARY SUPPLY FAIL – ALARM CONDITION

The green HEALTHY LED is extinguished, the red FAIL LED illuminated and the alarm contacts drop out. These conditions will self-reset after the supervision fail condition is corrected. The front panel slide switch is not fitted to XRD versions with the LED flag option. The red FAIL LED will also be extinguished when the auxiliary supply falls below 50% of nominal.

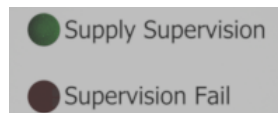

Contact Ratings

Contact material	AgNi	
Maximum switching voltage	250 V dc / 440 V ac	
Minimum switching voltage	5 V	
Minimum switching current	5 mA	
Contact resistance	< 100 mΩ (initial)	
AC break capacity (rated load)	AC1	8 A / 250 V
	AC15 (B300)	3 A / 120 V 1.5 A / 240 V
DC break capacity (rated load)	DC1	8 A / 24 V 0.4 A / 110 V 0.3 A / 220 V
		DC13 (R300)
	Max AC breaking capacity	2,000 VA



Figure 7: XRD-5 front panel
Left – Panel mount

Right – rail mount

Description

The operating element of the XRD-6 comprises two supervision elements A and B, which combine to hold in a heavy duty 3 contact attracted armature relay.

Supervision is active with the circuit breaker in the open or closed position via the “a and b” CB auxiliary contacts.

Supervision also remains active during tripping operations and irrespective of the status of the tripping relay contact

An important characteristic of the design is the low level of current required to flow through the CB coil for correct operation of the supervision scheme. A constant low supervision current is maintained irrespective of the circuit breaker open or closed position. This results in low power dissipation in the XRD-6 circuit and the circuit breaker coil which reduces the possibility of nuisance tripping.

Supervision with Circuit De-energized

CIRCUIT BREAKER OPEN AND TRIP CONTACT OPEN

Figure 8 shows a typical tripping circuit with the XRD-6 employed to supervise the circuit continuity, the circuit breaker coil and the auxiliary supply.

The blue lines depict the supervised circuits and red arrows the path of the supervision current through supervision element A with the auxiliary supply applied and the circuit breaker open.

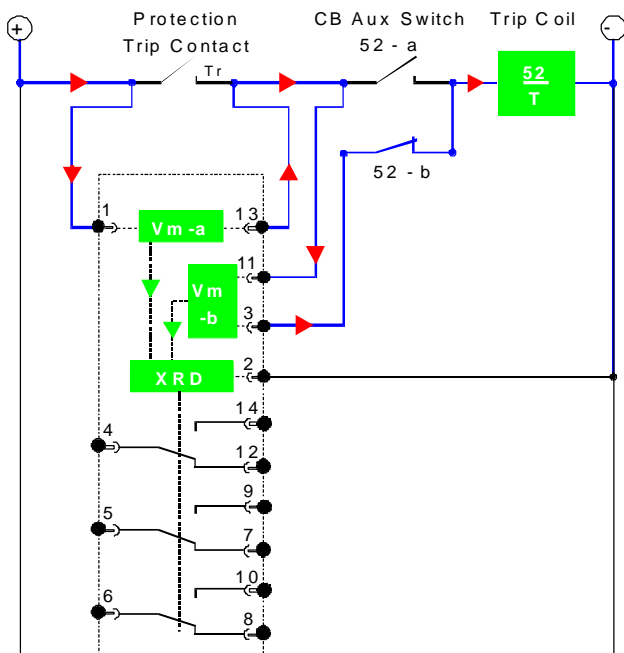

Figure 8: Delta XRD-6 – CB open

Functional Diagrams

Figures 8 to 13 depict how the supervision elements A and B monitor circuit continuity under all conditions:

Figure 8	CB open	Trip contact open	Auxiliary supply available
Figure 9	CB closing	Trip contact open	
Figure 10	CB closed	Trip contact open	
Figure 11	CB opening	Trip contact closed	
Figure 12	CB open	Trip contact closed	
Figure 13	Alarm condition		

Supervision during Circuit Breaker Closure

CIRCUIT BREAKER CLOSING AND TRIP CONTACT OPEN

Closure of the circuit breaker could cause the supervision circuits to be interrupted for the duration of the circuit breaker operate time. During this interval a >400 ms time delay holds in the alarm relay contacts.

Figure 9 shows the loss of supervision current through both the A and B supervision elements for the duration of the circuit breaker operating period.

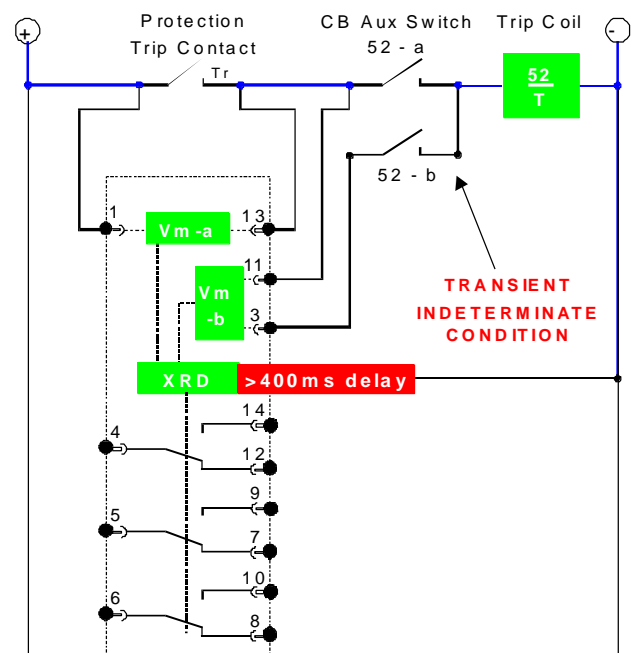

Figure 9: Delta XRD-6 - CB closing

Supervision with Circuit Energized

CIRCUIT BREAKER CLOSED AND TRIP CONTACT OPEN

Figure 10 shows a typical tripping circuit with the XRD-6 employed to supervise the circuit continuity, the circuit breaker coil and the auxiliary supply.

The blue lines depict the supervised circuits and red arrows the path of the supervision current through supervision element A with the auxiliary supply applied and the circuit breaker closed.

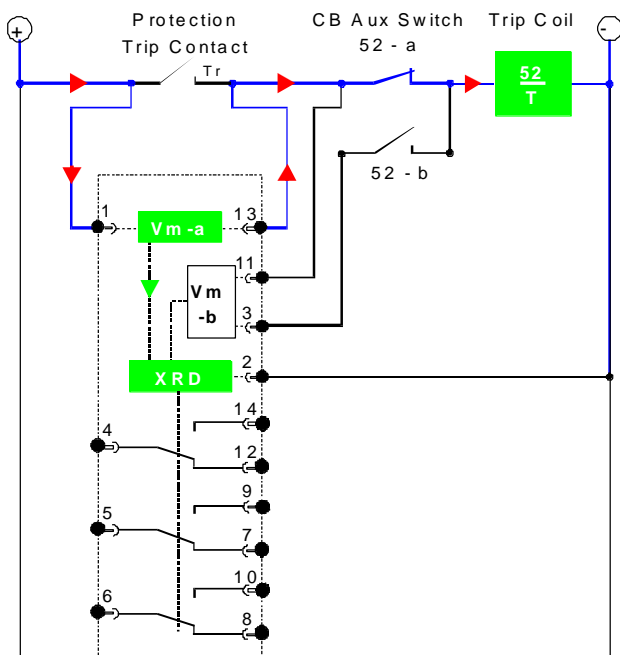

Figure 10: Delta XRD-6 – CB closed

Supervision during Circuit Breaker Operation

CIRCUIT BREAKER OPENING AND TRIP CONTACT CLOSED

Operation of the protection relay trip contact will cause the supervision circuits to be interrupted for the duration of the circuit breaker operate time. During this interval a >400ms time delay holds in the XRD-6 alarm relay contacts.

Figure 11 shows the loss of supervision current through both the A and B supervision elements for the duration of the circuit breaker operating period.

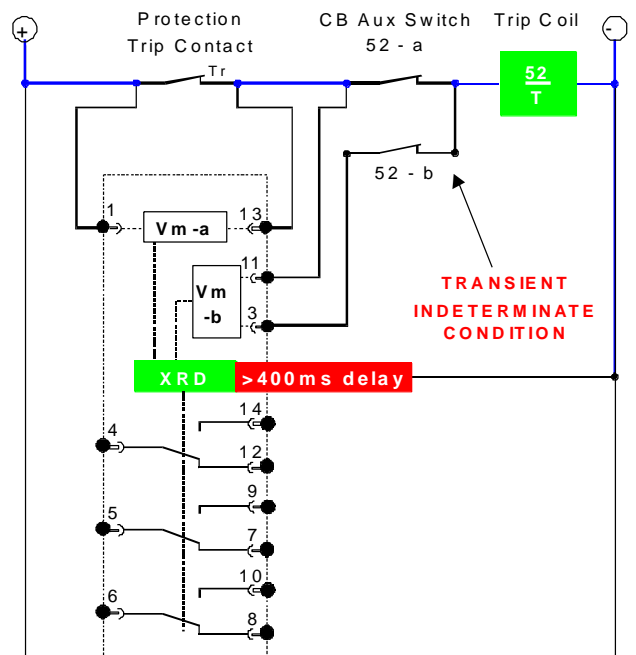

Figure 11: Delta XRD-6 - CB opening

Supervision with Circuit Tripped

CIRCUIT BREAKER OPEN AND TRIP CONTACT CLOSED

Figure 12 shows the path of the supervision current with the auxiliary supply applied and the circuit breaker in the open condition. The blue lines depict the supervised circuits and red arrows the path of the supervision current through supervision element B. Note that the supervision element A is shorted out by the closed trip relay contact. Supervision will also function with the trip relay contact reset (Open), as shown in figure 8.

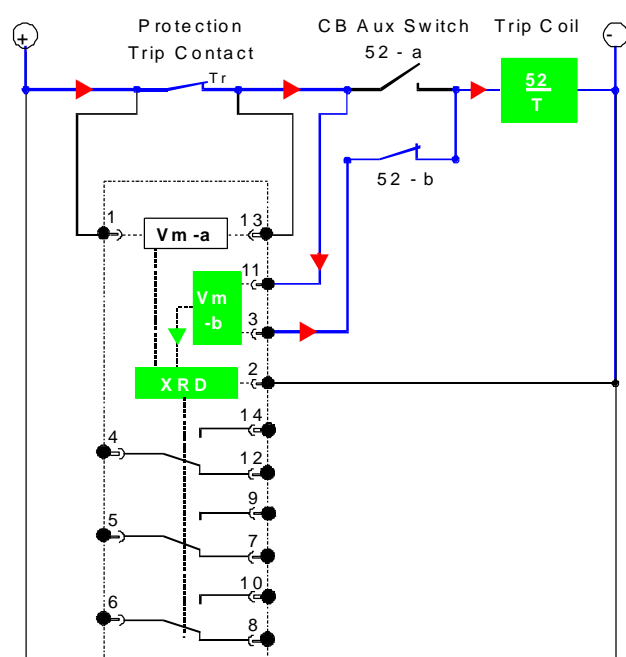

Figure 12: Delta XRD-6 – CB open

Normal Operating Conditions

TRIP CIRCUIT AND AUXILIARY SUPPLY HEALTHY

Normal operating condition is indicated on the front panel via a green LED and the alarm contact being picked up.

Abnormal Conditions

- > TRIP CIRCUIT FAIL
- > TRIP SUPPLY FAIL
- > CB TRIP COIL FAIL

Under abnormal trip circuit or CB trip coil conditions, supervision elements A and B will be unable to detect supervision current. After a time delay of >400 ms the XRD-6 alarm relay will drop out and the hand reset flag activated. Under abnormal trip supply conditions, the XRD-6 alarm relay will drop out after a time delay of >200 ms. Loss of supply will cause the green HEALTHY LED to be extinguished.

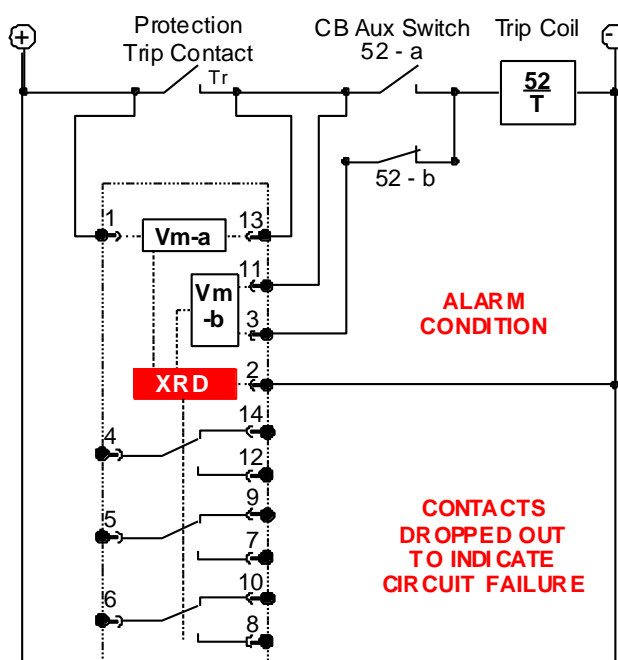

Figure 13: Delta XRD-6 – Alarm condition

Trip Circuit Resistance & Supervision Current

The XRD-6 circuit design is optimized to minimize the supervision current in the CB trip coil to avoid the possibility of nuisance tripping. Combined resistance of the circuit breaker and CB trip coil must be less than the maximum tabulated below to ensure adequate supervision current flows through the XRD-6.

CB Open (52a Open and 52b Closed)			
Nominal	Maximum CB trip coil resistance (ohms)	Approximate voltage monitor equivalent resistance (ohms)	Supervision current * (mA)
24V	1K	42K	0.25-0.8
32V	2K5	56K	0.25-0.8
48V	5K	86K	0.3-0.8
110V	20K	190K	0.3-0.8
125V	23K	216K	0.3-0.8
220V	40K	378K	0.3-0.8
240V	43K	442K	0.3-0.8
250V	45K	442K	0.3-0.8

CB Closed (52a Closed and 52b Open)			
Nominal	Maximum CB trip coil resistance (ohms)	Approximate voltage monitor equivalent resistance (ohms)	Supervision current * (mA)
24V	1K	21K	0.6-1.4
32V	2K5	28K	0.6-1.4
48V	5K	43K	0.7-1.4
110V	20K	95K	0.7-1.4
125V	23K	108K	0.7-1.4
220V	40K	189K	0.7-1.4
240V	43K	221K	0.7-1.4
250V	45K	221K	0.7-1.4

Operating Voltage Range

70% to 120% of nominal continuous at 25 degrees Celsius

Drop-out Voltage

The highest voltage level at which the relay will drop out and signal an alarm is 70% of nominal.

The lowest voltage level at which the relay will remain picked up is 35% of nominal. An alarm signal condition is output for input voltages below 35% of nominal.

Drop-out Time

Trip circuit fail: 400-550 ms

Loss of supply: 200-400 ms

Trip Supply Burden

The actual operating burden is dependent on the combined circuit breaker and CB trip circuit wiring.

Alarm Circuit Burden

The maximum XRD-6 relay burdens are as follows.

Nominal	Healthy	Alarmed	Supervision
24V	4.5W	0.3W	0.05W
32V	5.0W	0.5W	0.05W
48V	4.5W	0.75W	0.08W
110V	4.5W	1.0W	0.20W
125V	4.5W	1.0W	0.25W
220V	5.5W	1.9W	0.40W
240V	5.5W	2.0W	0.40W
250V	5.5W	2.0W	0.45W

Alarm Contacts

Standard: 3 C/O

Tripping Relays

Self-reset or latching type lockout type tripping relays may be employed with the XRD-6 trip circuit supervision scheme.

Contact Ratings

XRD versions		XRD-4 and XRD-6
Contact material		Ag
Operating Voltage		Voltage free
Isolation across open contacts		1 kV rms
Make and carry		7 A all contacts 10 A any two contacts
Peak inrush current		30 A for 200ms
AC break capacity (rated load)	AC1	10 A / 230 V
DC break capacity (rated load)	DC1	1 A / 110 V 0.7 A / 220 V
Switching voltage:	Maximum	300 V dc / 440 V ac
	Minimum	12 V
Minimum switching current		10 mA

Description

The XRD-7 provides similar functionality to the XRD-6 described in the previous section. For technical details not found in this section, reference should be made to the XRD-6 data. Technical data specific to the XRD-7 are as follows:

Alarm Signalling

- > 2 C/O alarm contacts
- > Self-reset red alarm LED

Normal Operating Conditions

TRIP CIRCUIT AND AUXILIARY SUPPLY HEALTHY

Normal operating condition is indicated on the front panel via a green LED and the alarm contact being picked up.

Abnormal Operating Condition

TRIP CIRCUIT FAIL – ALARM CONDITION

The green HEALTHY LED is extinguished, the red FAIL LED illuminated and the alarm contacts drop out. These conditions will self-reset after the supervision fail condition is corrected. The front panel slide switch is not fitted to XRD versions with the LED flag option.

TRIP SUPPLY FAIL – ALARM CONDITION

The red FAIL LED will also be extinguished when the auxiliary supply falls below 50% of nominal.

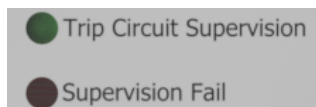

Contact Ratings

Contact material	AgNi	
Maximum switching voltage	250 V dc / 440 V ac	
Minimum switching voltage	5 V	
Minimum switching current	5 mA	
Contact resistance	< 100 mΩ (initial)	
AC break capacity (rated load)	AC1	8 A / 250 V
	AC15 (B300)	3 A / 120 V 1.5 A / 240 V
DC break capacity (rated load)	DC1	8 A / 24 V 0.4 A / 110 V 0.3 A / 220 V
		DC13 (R300)
	Max AC breaking capacity	2,000 VA



Figure: 14: XRD-7 front panel
Left – Panel mount

Right – rail mount

ATMOSPHERIC ENVIRONMENT

Temperature

Standard	IEC 60068-2-1, IEC 60068-2-2	
Test Identification	Test specification	Auxiliary power Supply voltage
Operating Range	-10 to +55°C	Min and Max
Storage Range	-25 to +70°C	Non-energized
Test duration	16 hours at top and bottom temperatures	

Damp Heat (Humidity)

Standard	IEC 680068-2-78 ENA TS 48-5, Issue 3, 2010	
Test Identification	Test specification	
Operating Range	40°C and 93% RH non- condensing	
Test duration	16 hours	

IP Rating

Standard	IEC 60529 ENA TS 48-5, Issue 3, 2010	
Test Identification	Test specification	
Installed	IP5x	

MECHANICAL ENVIRONMENT

Vibration - Sinusoidal

Standard	IEC 60255-21-1 Class 1	
Test Identification	Test specification	Variation
Vibration Response in each of 3 axes	0.035 mm/0.5 gn peak 1 sweep cycle 10-150 Hz	≤5%
Vibration Endurance in each of 3 axes	1.0 gn peak 20 sweep cycles 10-150 Hz	Non- energized

Shock and Bump

Standard	IEC 60255-21-2 Class 1	
Test Identification	Test specification	Variation
Shock Response in each of 3 axes	5 gn, 11 ms, 3 pulses in each direction	≤5%
Shock Withstand in each of 3 axes	15 gn, 11 ms, 3 pulses in each direction	Non- energized
Bump Test in each of 3 axes	10 gn, 16 ms, 1,000 bumps in each direction	Non- energized

Seismic

Standard	IEC 60255-21-3 Class 1	
Test Identification	Test specification	Variation
Seismic Response Horizontal, on each axis	3.5 mm/1.0 gn, 1 sweep cycle 1-35Hz	≤5%
Seismic Response Vertical	1.5 mm/0.5 gn, 1 sweep cycle 1-35Hz	≤5%

Mechanical Characteristics

Mechanical life at load	Resistive 8 A/ 250 V DC	>10 ⁵ cycles
	L/R=40ms, 0.15 A/ 220 V DC	
Max operation frequency at rated load		600 cycles /hour

ELECTRICAL ENVIRONMENT

Clearances and Creepage Distances

Standard	IEC 60255-26, #10.6.3
Test Identification	Test specification
Pollution degree	2
Overvoltage category	III
Rated insulation voltage	300 V rms or d.c.
Clearances and Creepage Compliance	CAD drawings assessment

Safety-related Electrical Tests

Standard	IEC 60255-27, #10.6.4
Test Identification	Test specification
Between Independent Circuits	5 kV 1.2/50 μ s 0.5 J 3 pulses of each polarity 2.0 kV ac rms for 1 minute
Any Terminal and Earth	5 kV 1.2/50 μ s 0.5 J 3 pulses of each polarity 2.0 kV ac rms for 1 minute
Across Normally Open Contacts	1 kV ac rms for 1 minute

Electrical Environment and Flammability

Standard	IEC 60255-27, #10.6.5
Test Identification	Test specification
Single-fault condition	Assessment for Opened and Closed-circuit cases
Single-fault condition	Assessment
Maximum temperature of accessible parts at ambient temperature +40°C	< 80°C
Flammability of insulating materials, components and fire enclosures	Assessment

Reverse Polarity and Slow Ramp Test

Standard	IEC 60255-27, #10.6.6
Test Identification	Test specification
Maximum voltage d.c.	V start-up + 20%
Minimum voltage d.c.	V shutdown - 20%
Ramp down/up gradient	1 V/min

ELECTROMAGNETIC COMPATIBILITY (EMC)

IMMUNITY

Electrostatic Discharge (ESD)

Standard	IEC 60255-26, #7.2.3, Acceptance criterion B	
Port	Enclosure	
Test Identification	Test specification	Variation
Air Discharge	8 kV	≤5%

Radiated Electromagnetic Field

Standard	IEC 60255-26, #7.2.4, Acceptance criterion A	
Port	Enclosure	
Test Identification	Test specification	Variation
Frequency sweep	10 V rms, 80 to 1000 MHz 1,400 to 2,700 MHz	≤5%
Spot frequencies	10 V rms, 80, 160, 380, 450, 900, 1,850 and 2,150 MHz	≤5%

Fast Transients (EFT)

Standard	IEC 60255-26, #7.2.5, Acceptance criterion B	
Port	Input and Output ports	
Test level	Test specification	Variation
Zone A	4 kV peak, 5/50 ns, 5 kHz	≤5%

Slow Damped Oscillatory Wave (HFD)

Standard	IEC 60255-26, #7.2.6, Acceptance criterion B	
Port	Auxiliary Power Supply, Input and Output	
Test Identification	Test specification	Variation
Common Mode	1 MHz 2.5 kV peak	≤5%
Differential Mode	1 MHz 1.0 kV peak	≤5%

Surge

Standard	IEC 60255-26, #7.2.7, Acceptance criterion B	
Port	Auxiliary Power Supply, Input and Output	
Test Identification	Test specification	Variation
Line-to-earth	4 kV peak	≤10%
Line-to-line	2 kV peak	≤10%

Conducted Disturbance Induced by RF Fields

Standard	IEC 60255-26, #7.2.8, Acceptance criterion A	
Port	Auxiliary Power Supply, Input and Output	
Test Identification	Test specification	Variation
Frequency sweep	10 V rms, 0.15 to 80 MHz	≤5%
Spot frequencies	10 V rms, 27 & 68 MHz	≤5%

Power Frequency Magnetic Field

Standard	IEC 60255-26, #7.2.10	
Port	Enclosure only	
Test Identification	Test specification	
Continuous ≥ 60 s	30 A/m - Acceptance criterion A	
Short time 1 s to 3 s	300 A/m - Acceptance criterion B	

XRD-4 DC Supply Supervision

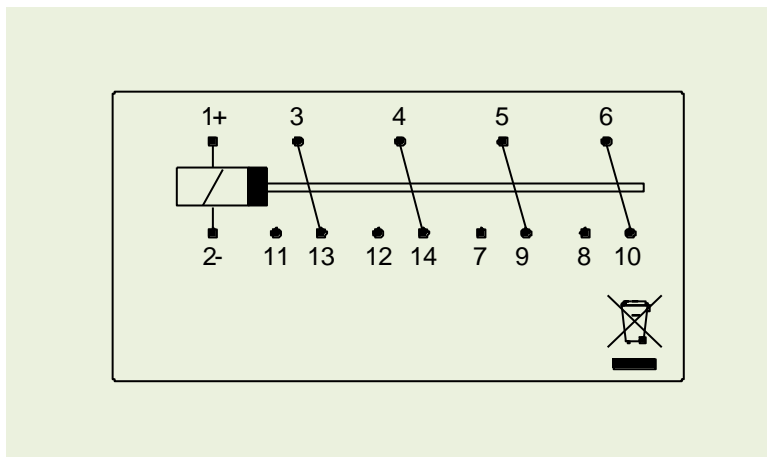

XRD-5 DC Supply Supervision

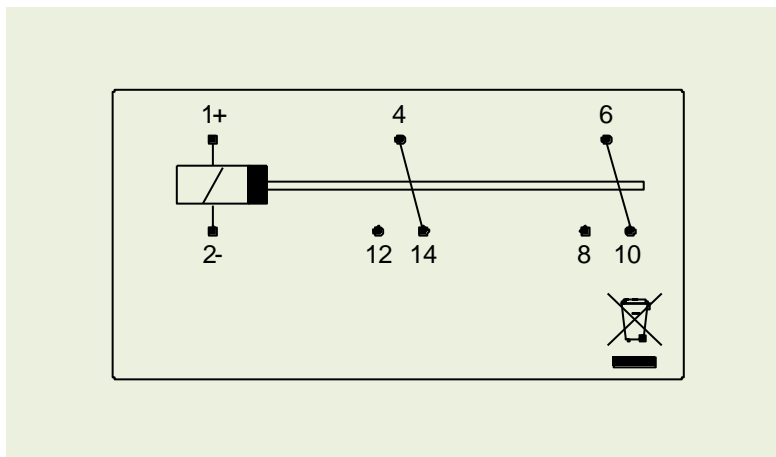

XRD-6 Trip Circuit Supervision

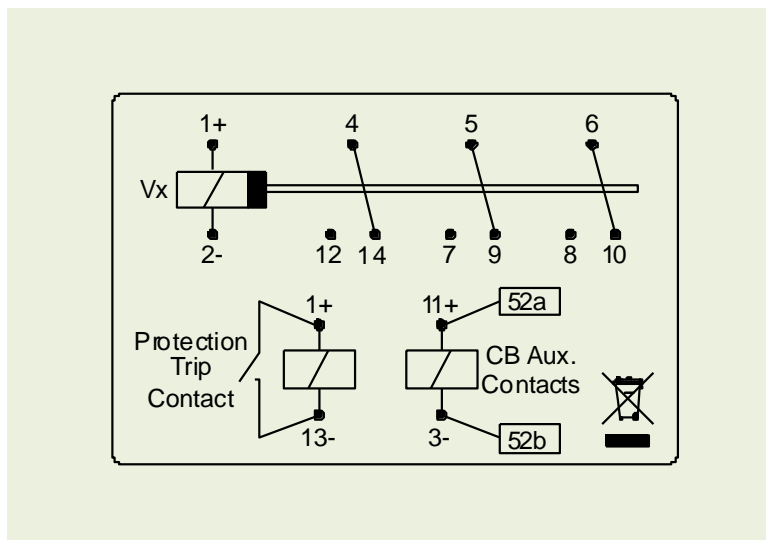

XRD-7 Trip Circuit Supervision

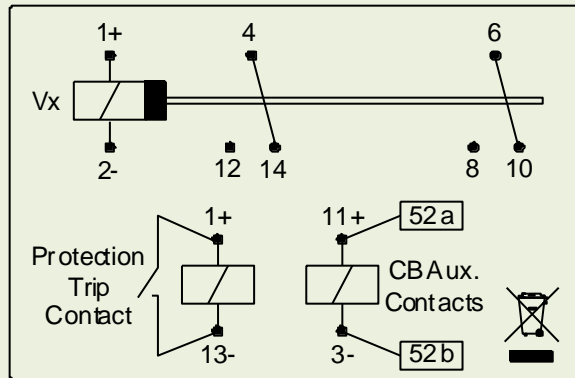

Wiring Notes

Relays are shown in the non-powered (Alarm) condition.

Note the connection polarity for correct DC operation.

A wiring diagram is also printed on the front panel of the relay module for easy reference in the field.

Mounting and Dimensions

19 Inch Rack Mount Rear Connect (TBD-R Terminal Block)



19 inch rack mount
2U x 2U



Adapter plate for 2x units
in a 2U x 4U rack frame



Adapter plate for 4x units
in a 4U x 4U rack frame

Surface Mount Rear Connect (TBD-R Terminal Block)



Panel cut-out to mount surface rear
connect base

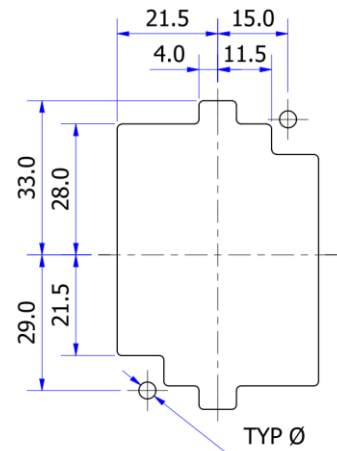
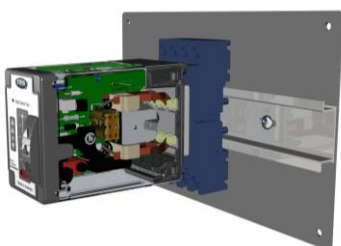
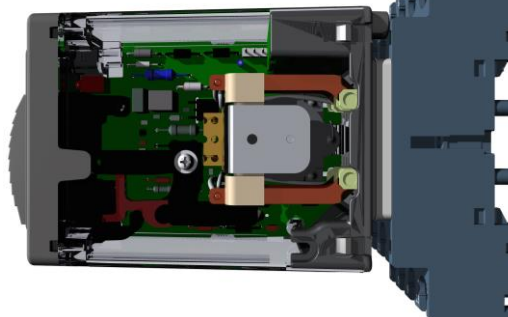

TABLE 1 - HOLE DIA	
PANEL THICKNESS (T)	HOLE DIA (Ø)
1mm < T < 2mm	3.6mm
T > 2mm	3.7mm

Surface or Rail Mount Front Connect (TBD-F Terminal Block)



65



94

30



45

87

Mounting and Dimensions

Flush Panel Mount Rear Connect (TBD-R Terminal Block)

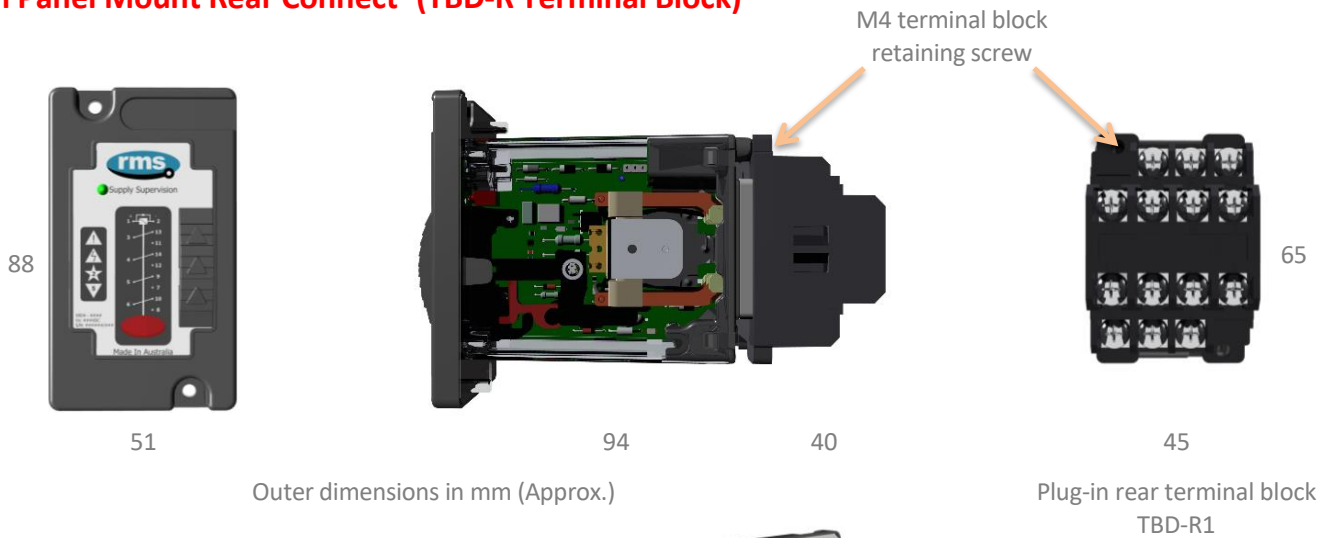

Outer dimensions in mm (Approx.)



Flush panel mounting
Rear connect terminal block

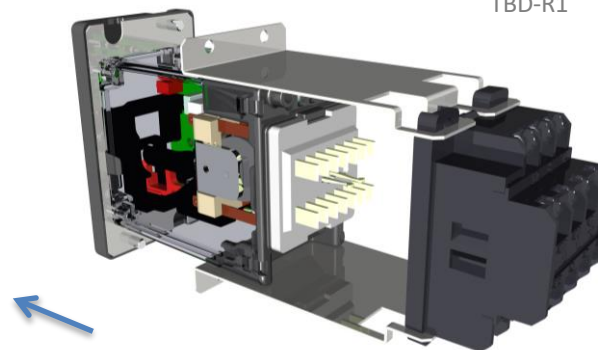

Rear connect terminal base secured to the front panel with optional retention plates - TBD-R2. Relay shown partially drawn-out of the panel.

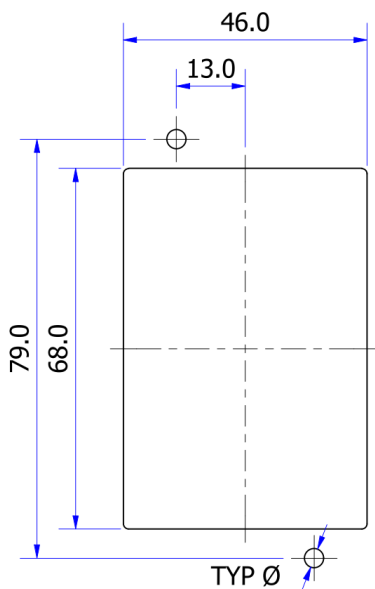

TABLE 1 - HOLE DIA	
PANEL THICKNESS (T)	HOLE DIA (Ø)
1mm < T < 2mm	3.6mm
T > 2mm	3.7mm

Panel cut-out to flush mount relay for use with rear connect TBD-R1 base

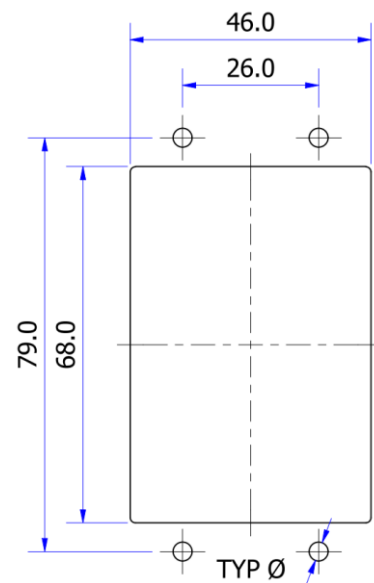

TABLE 1 - HOLE DIA	
PANEL THICKNESS (T)	HOLE DIA (Ø)
1mm < T < 2mm	3.6mm
T > 2mm	3.7mm

Panel cut-out to flush mount relay for use with rear connect TBD-R2 base

Delta XRD Relay Order Codes

XRD -			
Supervision Function	4		Trip supply supervision and hand-reset mechanical flag alarm
	5		Trip supply supervision with self-reset LED alarm
	6		Trip circuit supervision with hand reset mechanical flag alarm
	7		Trip circuit supervision with self-reset LED alarm
Nominal Operate Voltage	A		24 V dc
	B		32 V dc
	C		48 V dc
	D		110 V dc
	E		125 V dc
	F		220 V dc
	G		240 V dc
	H		250 V dc
Mounting Configuration	A		Surface or rail mounting without terminal block
	A-F		Surface or rail mounting including TBD-F terminal block
	A-F-IP2X		Surface or rail mounting including TBD-F-IP2X terminal block
	A-R1		Surface mount including TBD-R1 terminal block
	A-R1-IP2X		Surface mount including TBD-R1-IP2X terminal block
	B		Panel mounting without terminal block
	B-R1		Panel mounting including TBD-R1 terminal block
	B-R1-IP2X		Panel mounting including TBD-R1-IP2X terminal block
	B-R2		Panel mounting including TBD-R2 terminal block
	B-R2-IP2X		Panel mounting including TBD-R2-IP2X terminal block
			# Refer note 1

NOTE 1 The Delta relay will be supplied for mounting as per the order code specified. However, the relay mounting can be changed from DIN rail mount (Code A) to Panel Mount (Code B) or vice versa using the TBD-AC Relay Mount Conversion Kit. This provides more flexibility to manage changes at site without returning to the factory for modification. The front panel relay ID employs a # code in place of the mounting configuration code to indicate that either mounting configuration is possible. The mounting configuration code **A** or **B** is shown on the escutcheon moulding – Refer to the two alternative TRD4-1D# escutcheon examples depicted.

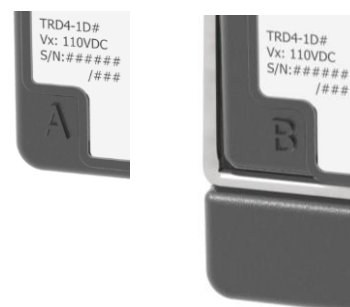

Refer to Appendix 1 for further detail on IP2X terminal blocks.

Delta Terminal Block Order Codes

TBD -	<input type="text"/>	
Terminal Block Connection	F	Front connect
	F-IP2X	Front connect with IP2X covers
	R1	Rear connect
	R1-IP2X	Rear connect with IP2X covers
	R2	Rear connect using terminal block retention plates
	R2-IP2X	Rear connect with IP2X covers and terminal block retention plates

Delta Accessories

Relay mount components	TBD-AC	Relay mount conversion kit (Excludes terminal block)
Panel mount frames	TBD-AD	Dual - 4U x 2U frame to rack mount 2 high x 1 wide Delta relays
	TBD-AQ	Quad - 4U x 4U frame to rack mount 2 high x 2 wide Delta relays

IP2X Terminal Options

Surface or Rail Mount Front Connect (TBD-F-IP2X Terminal Block)



Surface Mount Rear Connect (TBD-R1-IP2X Terminal Block)

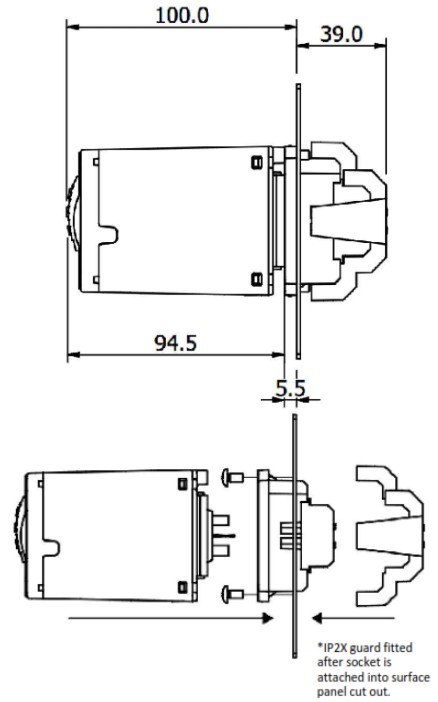

Flush Panel Mount Rear Connect (TBD-R1-IP2X Terminal Block)

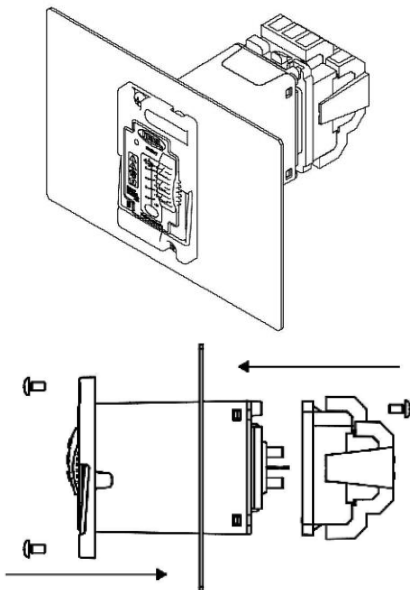

Flush Panel Mount Rear Connect (TBD-R2-IP2X Terminal Block)

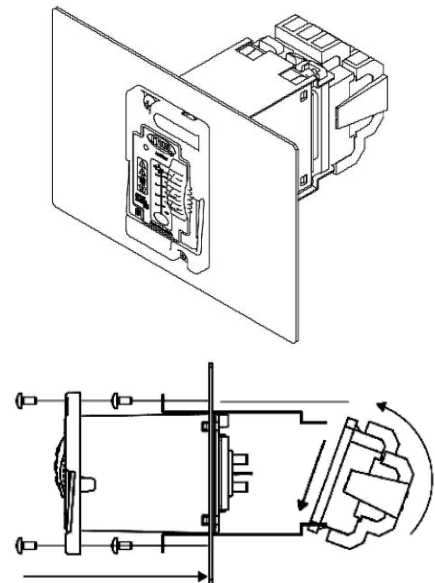

RMS Mors Smitt
19 Southern Court
Keysborough, VIC 3173, Australia
Tel: +61 (0)3 8544 1200
sales.rms@wabtec.com



Wabtec Netherlands B.V.
Darwinstraat 10
6718 XR Ede, Netherlands
Tel: +31 (0)88 600 4500
sales.msbv@wabtec.com



Visit www.morssmitt.com/rms for the latest product information.

Due to RMS continuous product improvement policy this information is subject to change without notice