

AUXILIARY | TRIPPING | SUPERVISION

# Alpha XR

High reliability electro-mechanical supervision relays for power utility protection and control applications.

- > Trip supply supervision
- > Trip circuit supervision
- > Trip relay supervision
- > US Patent – US 8,115,578 B2
- > Made in Australia





## Cross Reference

		Alpha XR Code
MVAX11		XR5-00-1
MVAX12	XR152, 153	XR5-00-4
MVAX31	XR350, 351	XR5-00-6

## Description

The XR range represents a new generation of high reliability electro-mechanical relays for power utility protection and control applications.

The XR is built on the Alpha relay platform providing high performance and reliability while reducing production and supply lead times.

Application of the XR supervision relays ensures reliable operation of up to 5 output contacts in a compact size 2 draw out case. The unique patented design and topology ensures minimal contact bounce.

## Features

- > Rugged modular construction
- > High reliability double action contacts
- > 5 heavy duty contact versions available in a range of Make and Break combinations
- > High visibility electro-mechanical flag  
Hand reset and self-reset versions available to indicate supervision alarm condition
- > Optional supervision Healthy LED
- > Rated operate voltages available for 30/32, 48, 110, 125, 220, 240 or 250 Volts DC nominal auxiliary supplies
- > Low burden
- > Rack or flush mounting
- > Compact size 2 draw out case
- > M4 screw terminals
- > Simple to specify and order

## Application

The Alpha XR Series Relays are low burden electro-mechanical supervision relays for application on high security tripping and auxiliary supply circuits.

The Alpha XR relays have been designed to provide a balance of low burden to minimize the possibility of circuit breaker mal-operation while maintaining a minimum contact whetting current to avoid nuisance alarm conditions.

A key feature of the design is a high visibility flag indicator that can only be reset under healthy supervision conditions. An optional green Healthy LED may also be specified. Failure of the circuit or supply being supervised will cause the main relay element to drop out, the flag to fall and the alarm contacts to change state.

A wide voltage operating range and time delays ensures reliable operation. The XR range is packaged in a draw out case system and can be either flush panel or rack mounted.

## Model Designation

Alpha XR models:

- > XR5-00-1 Trip relay coil supervision
- > XR5-00-4 Trip supply supervision
- > XR5-00-6 Single pole trip circuit supervision

## Alpha XR Supervision Relay Specifications

Refer to the following sections in this publication:

- > Front Panel Layout
- > Trip Relay Supervision
- > DC Supply Supervision
- > Trip Circuit Supervision
- > General Specifications
- > Ratings and Standards
- > Case Details
- > Terminal Wiring
- > Ordering codes

## Front Panel Layout

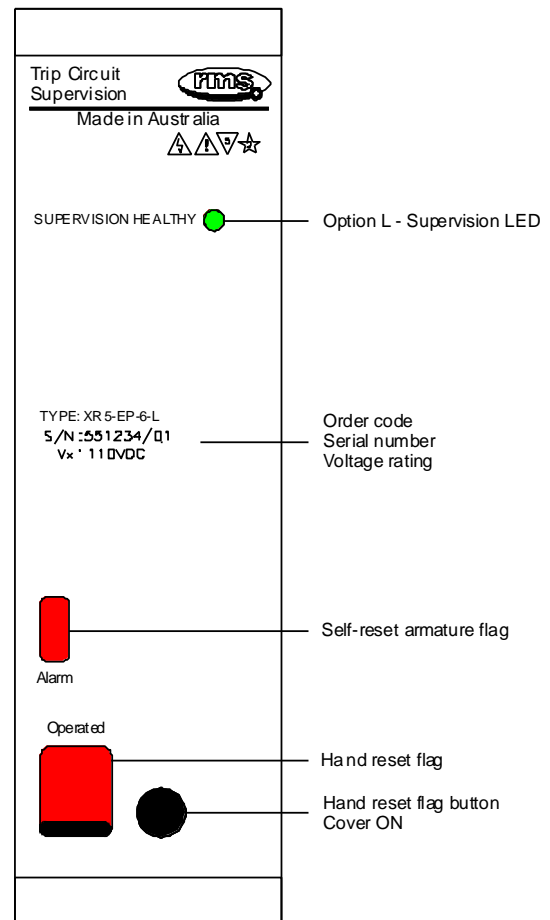

Figure 1: Alpha XR5-00-6

Front panel layout depicting flags, resets and option positions

## Description

The XR5-00-1 relay is designed to supervise trip relay circuits utilizing high burden trip relays such as the Alpha TR, 2HS or 6RJ Series available from RMS.

The operating element of the XR5-00-1 comprises a single Alpha five contact heavy-duty attracted armature control relay with a single operating coil and delay slug. It has two dropping resistors R1 and R2 of equal ohmic value, connected in series with the coil.

If the circuit being supervised becomes open circuited or if the supply fails, the relay will become de-energized and an alarm is given - visual indication and 5 contacts change state.

Under healthy conditions supervision current flows through the voltage monitor Vm-a and the relay coil (AR5) is energized. If the circuit being supervised becomes open circuit or if the supply fails, the relay will become de-energized and an alarm is given (5 alarm contacts and flag indication).

To prevent the alarm being given when the circuit being supervised is operated, supervision current flows through the voltage monitor Vm-b to energize the relay coil (AR5). For this purpose, an additional normally open contact is required from the latching tripping relay as depicted in figures 2 to 4. A short time delay of >100ms, is incorporated to hold up the alarm relay during a normal trip relay operation.

## Normal Operating Conditions

### TRIP RELAY DE-ENERGIZED

Figure 2 shows a typical trip circuit with the XR5-00-1 employed to supervise the trip relay coil and the auxiliary supply. The blue lines depict the supervised circuits and red arrows depict the path of the supervision current with the auxiliary supply applied to the circuit with the trip relay de-energized.

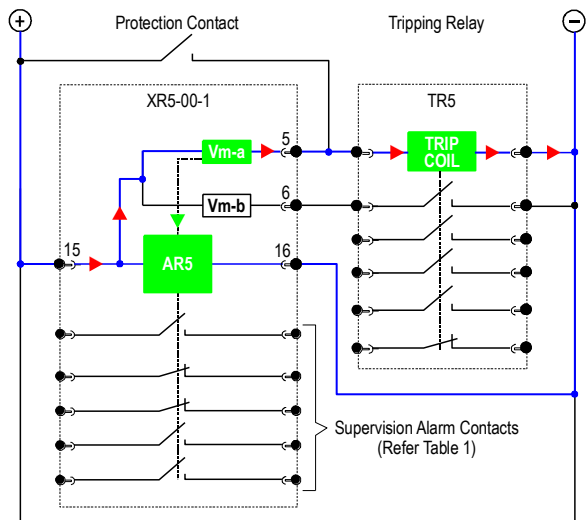

Figure 2: Alpha XR5-00-1 - Normal system condition

## Normal Operating Conditions

### CIRCUIT BREAKER OPEN – TRIPPED CONDITION

Figure 3 shows the path of the supervision current with the auxiliary supply applied and the trip relay operated. In this state the CB will be open and the trip relay coil is not monitored. The XR5-00-1 relay remains energized through a N/O contact on the trip relay indicating a healthy auxiliary supply.

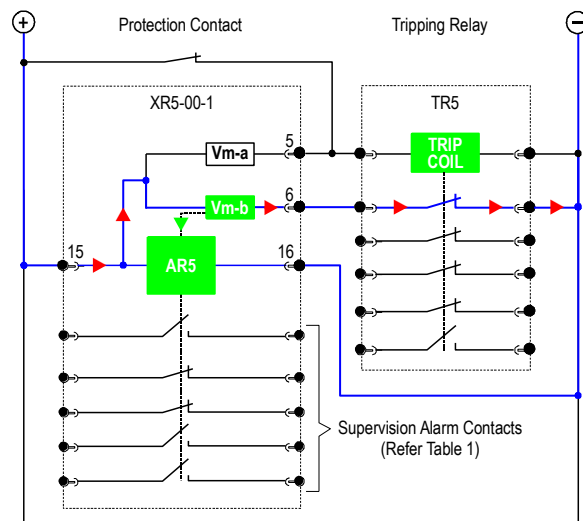

Figure 3: Alpha XR5-00-1 - Tripped condition

## Alarm Indication

All XR5 relay versions may be specified with a flag (target) indicator. The indicator consists of a high visibility solid day-glow orange mechanical flag. Refer to the Flag Indicators section under Technical Data for functional details.

## Trip Relay Coil Resistance & Supervision Current

The XR5-00-1 circuit design is optimized to minimize the supervision current in the tripping relay coil to avoid the possibility of nuisance tripping. Resistance of the tripping relay coil must be less than the maximum tabulated below to ensure adequate supervision current flows through the XR5-00-1.

Nominal supply (V)	Maximum tripping relay coil resistance (ohms)	Approximate voltage monitor Vm-a equivalent resistance (ohms)	Supervision current* (mA)
32	4k7	4k4	2.7 - 6.9
48	7k0	7k3	2.6 - 6.1
110	15k1	17k5	2.7 - 6.1
125	16k9	21k5	2.6 - 5.8
220	31k2	44k0	2.5 - 5.2
240	32k9	50k1	2.5 - 5.0
250	31k0	55k6	2.4 - 5.7

\* Actual supervision current is dependent on the tripping relay coil resistance.

## Trip Supply Burden

Allow a nominal 3 Watts for the alarm relay AR5 which is normally energized under healthy trip circuit conditions.

## Thermal Rating

All operate & reset circuits are designed to withstand continuous application of 120% of nominal voltage.

## Operating Voltage Range

Guaranteed operation between 70% and 120% of nominal rated DC operating voltage.

Note: The 70% of nominal value allows for correct operation of the relay even when there is a loss of battery charger supply for considerable periods.

To ensure guaranteed operation at 70% of nominal voltage the relay is manufactured to operate at a lower level to guarantee operation if the voltage falls to 70% of nominal voltage. Consequently, it will be found that these relays will operate below 70% of nominal voltage to allow for manufacturing tolerance on devices, this is normal and correct.

The 70% of nominal voltage figure does not indicate the relay pickup voltage.

## Drop-out Voltage

50-60% of nominal

The highest voltage level at which the relay will drop out and signal an alarm is 60% of nominal.

The lowest voltage level at which the relay will remain picked up is 50% of nominal. Below 50% of nominal an alarm signal condition is guaranteed.

## Reset (Drop-out) Time

Not less than 100ms when supply is switched from 100% to 50% of the nominal rated operating voltage.

## Pick-up Time

<70ms

## Contacts

Standard: 2M+3B  
 Other contact arrangements: Refer table 1  
 Drop out delay: >100ms

## Abnormal Operating Condition

CIRCUIT BREAKER TRIPPING DISABLED – ALARM CONDITION

Figure 4 shows the XR5-00-1 supervision relay dropped out due to the loss of circuit continuity. Loss of the supervision current due to a loss of the auxiliary supply or failure of the trip relay or associated circuit for >100ms will cause this condition.

An alarm is reported through the change in state of the five (5) alarm contacts and the front panel indicator(s).

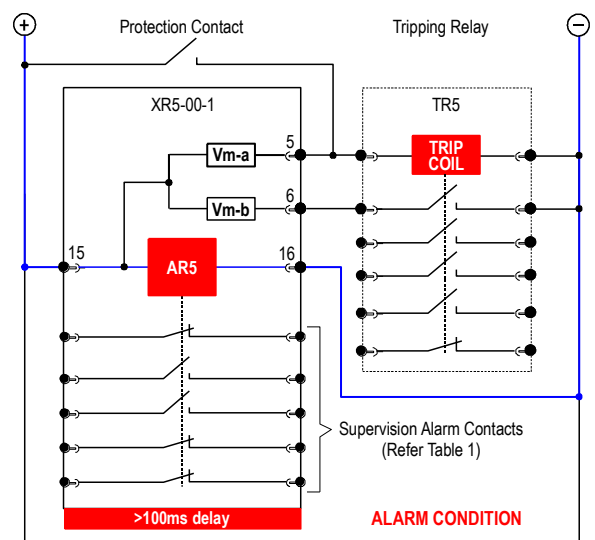

Figure 4: Alpha XR5-00-1 - Abnormal condition

## Description

The XR5-00-4 is designed to supervise DC auxiliary supplied employed on high security protection and tripping circuits employed in high voltage power systems. The XR5-00-4 comprises a single Alpha 5 heavy-duty attracted armature control relay with a single operating coil and delay slug.

Under healthy conditions, the coil is energized and if the supply fails, the relay will drop out to initiate a supply fail alarm. A short time delay is incorporated to avoid nuisance tripping due to switching transients.

## Circuit Resistance and Burden

The XR5-00-4 circuit design is optimized to minimize the supervision current to minimize the burden on the supervised DC supply. Allow a nominal 2.5 Watts for the supervision circuit and 3 Watts for the alarm relay AR5 which is normally energized under healthy trip circuit conditions.

## Thermal Rating

All circuits are designed to withstand continuous application of 120% of nominal voltage.

## Alarm Indication

All XR5 relay versions may be specified with a flag (target) indicator. The indicator consists of a high visibility solid day-glow orange mechanical flag. Refer to the Flag Indicators section under Technical Data for functional details.

## Operating Voltage Range

Guaranteed operation between 70% and 120% of nominal rated DC operating voltage.

Note: The 70% of nominal value allows for correct operation of the relay even when there is a loss of battery charger supply for considerable periods.

To ensure guaranteed operation at 70% of nominal voltage the relay is manufactured to operate at a lower level to guarantee operation if the voltage falls to 70% of nominal voltage. Consequently, it will be found that these relays will operate below 70% of nominal voltage to allow for manufacturing tolerance on devices, this is normal and correct.

The 70% of nominal voltage figure does not indicate the relay pickup voltage.

## Drop-out Voltage 50-60% of nominal

The highest voltage level at which the relay will drop out and signal an alarm is 60% of nominal.

The lowest voltage level at which the relay will remain picked up is 50% of nominal. Below 50% of nominal an alarm signal condition is guaranteed.

## Reset (Drop-out) Time

Greater than 100ms when supply is switched from 100% to 50% of the nominal rated operating voltage.

## Pick-up Time

<70ms

## Normal Operating Conditions

AUXILIARY SUPPLY AVAILABLE

Figure 5 shows a typical DC auxiliary supply circuit with the XR5-00-4 employed to supervise the auxiliary supply. The blue lines depict the supervised circuits and red arrows depict the path of the supervision current with a healthy auxiliary supply applied.

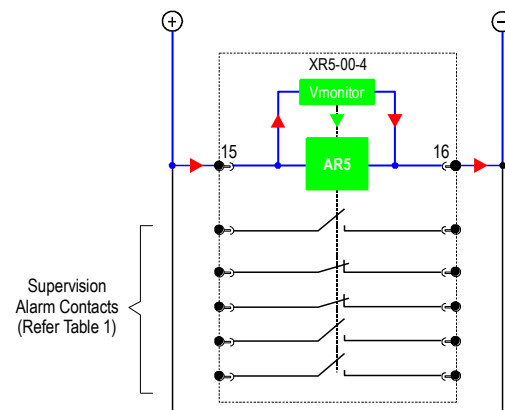

Figure 5: Alpha XR5-00-4 - Normal system condition

## Abnormal Operating Condition

AUXILIARY SUPPLY FAIL – ALARM CONDITION

Figure 6 shows the XR5-00-4 supervision relay dropped out due to the loss of auxiliary supply. Loss of the supervision current due to a loss of the auxiliary supply for >100ms will cause this condition.

An alarm is reported through the change in state of the five (5) alarm contacts and the front panel indicator(s).

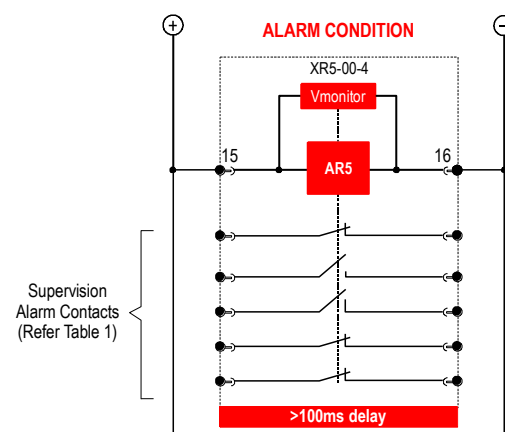

Figure 6: Alpha XR5-00-4 - Abnormal condition – Loss of supply



## Description

The operating element of the XR5-00-6 comprises two supervision elements Vm-a and Vm-b, which combine to hold in a heavy duty Alpha 5 contact attracted armature relay.

Supervision is active with the circuit breaker in the open or closed position via the “a and b” CB auxiliary contacts.

Supervision also remains active during tripping operations and irrespective of the status of the tripping relay contact

Figures 7 to 12 depict how the supervision element Vm-a and Vm-b monitor circuit continuity under all conditions:

Figure 7	CB open	Trip contact open	Auxiliary supply available
Figure 8	CB closing	Trip contact open	
Figure 9	CB closed	Trip contact open	
Figure 10	CB opening	Trip contact closed	
Figure 11	CB open	Trip contact closed	
Figure 12	Alarm condition		

An important characteristic of the design is the low level of current required to flow through the CB coil for correct operation of the supervision scheme. A constant low supervision current is maintained irrespective of the circuit breaker open or closed position. This results in low power dissipation in the XR5-00-6 circuit and the circuit breaker coil which reduces the possibility of nuisance tripping.

## Supervision with Circuit De-energized

### CIRCUIT BREAKER OPEN AND TRIP CONTACT OPEN

Figure 7 shows a typical tripping circuit with the XR5-00-6 employed to supervise the circuit continuity, the circuit breaker coil and the auxiliary supply.

The blue lines depict the supervised circuits and red arrows the path of the supervision current through supervision element Vm-a with the auxiliary supply applied and the circuit breaker open.

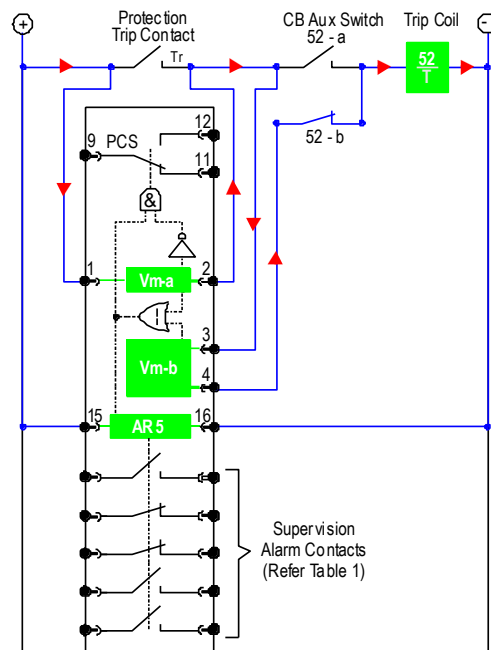

Figure 7: Alpha XR5-00-6 – CB open

## Supervision during Circuit Breaker Closure

### CIRCUIT BREAKER CLOSING AND TRIP CONTACT OPEN

Closure of the circuit breaker could cause the supervision circuits to be interrupted for the duration of the circuit breaker operate time. During this interval a 400 ms time delay holds in the AR5 alarm relay contacts.

Figure 8 shows the loss of supervision current through both the Vm-a and Vm-b supervision elements for the duration of the circuit breaker operating period.

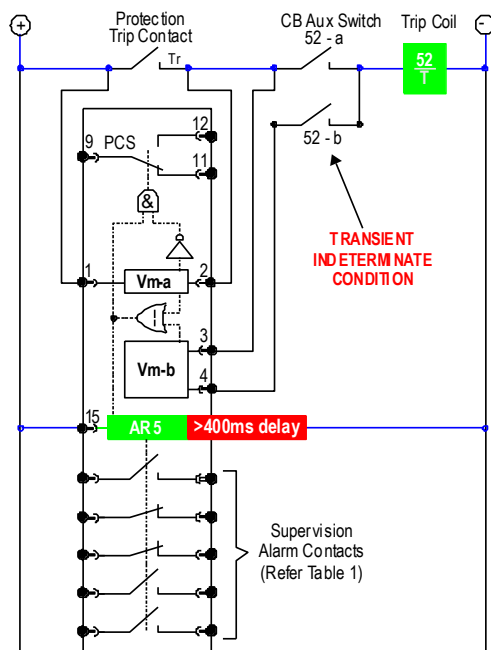

Figure 8: Alpha XR5-00-6 - CB closing

## Circuit Breaker Pre-closing Supervision Contact

The Protection Trip Contact (Tr) should be in the open (Reset) condition prior to closing the CB. The PCS contact shown in figures 7 to 12 provides an output for the Tr status:

THE PCS CONTACT IS PICKED UP WHEN TR IS CLOSED AND SUPERVISION IS HEALTHY.

This logic allows the PCS contact to be employed as an interlock on the CB reclose circuit to avoid an attempt to close the CB while a trip signal is present.

The PCS contact is conditioned by the trip circuit supervision release delay so it will remain picked up until the delay expires or the external circuit changes state.

PCS relay coil is not electrically isolated from the auxiliary supply. The PCS contacts are isolated from all other circuits and from the alarm contacts.

## Supervision with Circuit Energized

CIRCUIT BREAKER CLOSED AND TRIP CONTACT OPEN

Figure 9 shows a typical tripping circuit with the XR5-00-6 employed to supervise the circuit continuity, the circuit breaker coil and the auxiliary supply.

The blue lines depict the supervised circuits and red arrows the path of the supervision current through supervision element Vm-a with the auxiliary supply applied and the circuit breaker closed.

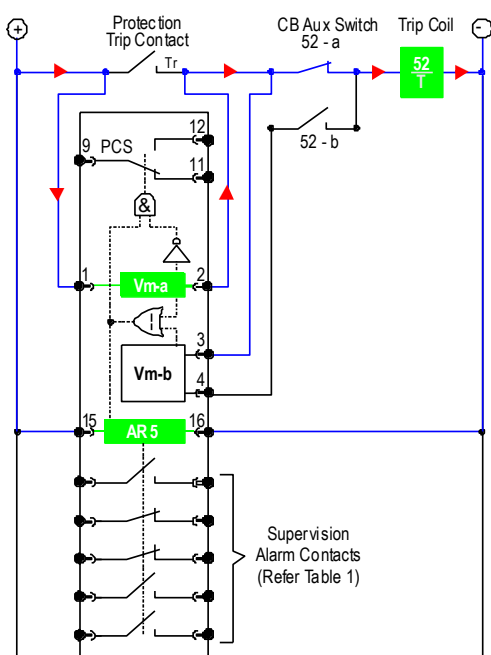

Figure 9: Alpha XR5-00-6 – CB closed

## Supervision during Circuit Breaker Operation

CIRCUIT BREAKER OPENING AND TRIP CONTACT CLOSED

Operation of the protection relay trip contact will cause the supervision circuits to be interrupted for the duration of the circuit breaker operate time. During this interval a 400ms time delay holds in the AR5 alarm relay contacts.

Figure 10 shows the loss of supervision current through both the Vm-a and Vm-b supervision elements for the duration of the circuit breaker operating period.

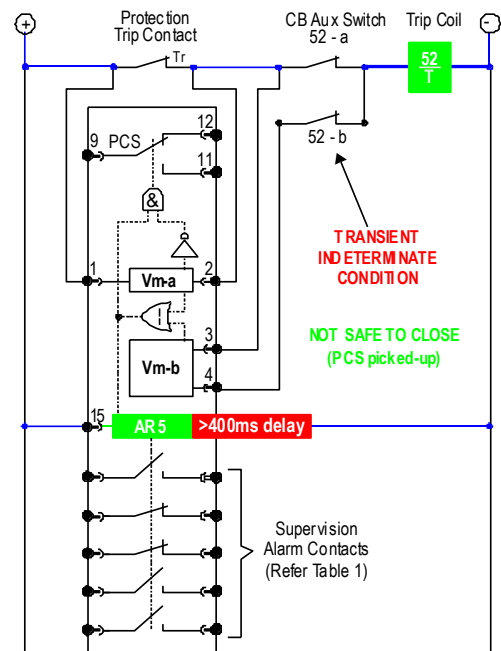

Figure 10: Alpha XR5-00-6 – Tr Closed and CB opening



## Supervision with Circuit Tripped

### CIRCUIT BREAKER OPEN AND TRIP CONTACT CLOSED

Figure 11 shows the path of the supervision current with the auxiliary supply applied and the circuit breaker in the open condition. The blue lines depict the supervised circuits and red arrows the path of the supervision current through supervision element B. Note that the supervision element Vm-a is shorted out by the closed trip relay contact. Supervision will also function with the trip relay contact reset (Open), as shown in figure 7.

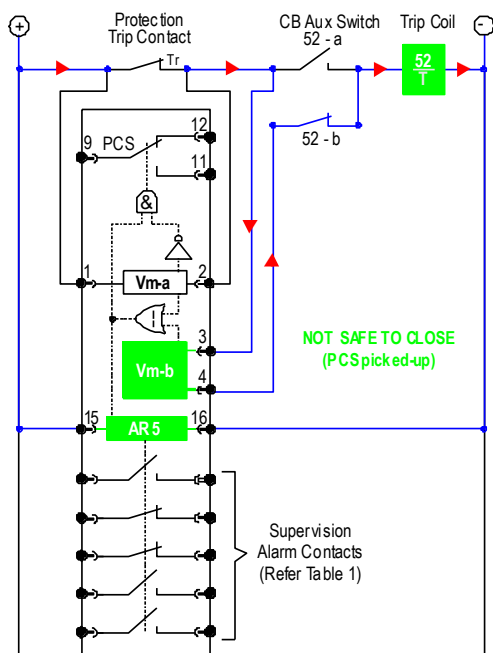

Figure 11: Alpha XR5-00-6 – Tr Closed and CB open

## Abnormal Conditions

- > TRIP CIRCUIT FAIL
- > TRIP SUPPLY FAIL
- > CB TRIP COIL FAIL

Under abnormal trip circuit or CB trip coil conditions, supervision elements Vm-a and Vm-b will be unable to detect supervision current. After a time delay of >400ms the AR5 relay will drop out and an alarm reported through the change in state of the five (5) alarm contacts and the front panel indicator(s).

Under abnormal trip supply conditions the AR5 relay will drop out after a time delay of >100ms.

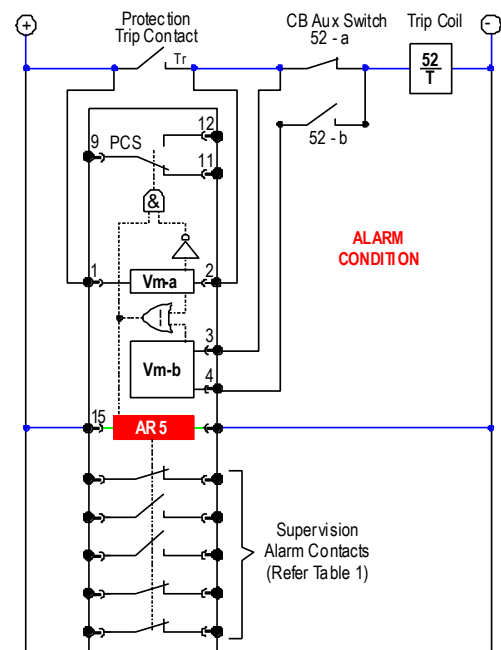

Figure 12: Alpha XR5-00-6 – Alarm condition

## Trip Supply Burden

The actual operating burden is dependent on the CB coil resistance.

## Trip Circuit Resistance & Supervision Current

The XR5-00-6 circuit design is optimized to minimize the supervision current in the CB trip coil to avoid the possibility of nuisance tripping. The resistance of the circuit breaker trip coil must be less than the maximum tabulated below to ensure adequate supervision current flows through the XR5-00-6.

Nominal supply (V)	Maximum CB trip coil resistance (ohms)	Approximate voltage monitor equivalent resistance* (ohms)	Supervision current** (mA)
32	4k7	4k4	2.7 - 6.9
48	7k0	7k3	2.6 - 6.1
110	15k1	17k5	2.7 - 6.1
125	16k9	21k5	2.6 - 5.8
220	31k2	44k0	2.5 - 5.2
240	32k9	50k1	2.5 - 5.0
250	31k0	55k6	2.4 - 5.7

\* The XR5-00-6 has been designed so that only one of either Vm-a or Vm-b is in circuit at any time.

\*\* Actual supervision current is dependent on the combined circuit breaker and CB trip coil resistance.

## Pre-closing Supervision Function Burden

Allow a nominal 2 Watts for the pre-closing switch (PCS), function which is normally energized when the Protection Trip Contact (Tr) is closed and supervision healthy.

## Alarm Circuit Burden

Allow a nominal 3 Watts for the alarm relay AR5 which is normally energized under healthy trip circuit conditions.

## Flag Operation

All XR5 relay versions may be specified with a flag (target) indicator. The indicator consists of a high visibility solid day-glow orange mechanical flag. Refer to the Flag Indicators section under Technical Data for functional details.

## Tripping Relays

Self-reset or latching type lockout type tripping relays may be employed with the TRX-00-6 trip circuit supervision scheme.

## Operating Voltage Range

Guaranteed operation between 70% and 120% of nominal rated DC operating voltage.

Note: The 70% of nominal value allows for correct operation of the relay even when there is a loss of battery charger supply for considerable periods.

To ensure guaranteed operation at 70% of nominal voltage the relay is manufactured to operate at a lower level to guarantee operation if the voltage falls to 70% of nominal voltage. Consequently, it will be found that these relays will operate below 70% of nominal voltage to allow for manufacturing tolerance on devices, this is normal and correct.

The 70% of nominal voltage figure does not indicate the relay pickup voltage.

## Drop-out Voltage

The highest voltage level at which the relay will drop out and signal an alarm is 60% of nominal.

The lowest voltage level at which the relay will remain picked up is 50% of nominal. Below 50% of nominal an alarm signal condition is guaranteed.

## Reset (Drop-out) Time

Not less than 100ms when supply is switched from 100% of nominal rated operating voltage to off. Not less than 400ms during trip circuit interruptions.

## Pick-up Time

<70ms

## Nominal Operating Voltages

32, 48, 110, 125, 220, 240 and 250V DC available.

## Contacts

Standard: 1M+4B

Other contact arrangements: Refer table 1

Drop out delay: >400ms

## Contact Rating

### ALARM CONTACT RATING

Make and Carry Continuously	
1,250 VA AC resistive	Limited at both 660 V and 8 A
1,250 W DC resistive	Limited at both 660 V and 8 A

Make and Carry for 3 seconds	
7,500 VA AC resistive	Limited at both 660 V and 30 A
7,500 W DC resistive	Limited at both 660 V and 30 A

AC Break Capacity	
1,250 VA AC resistive	Limited at both 8 A and 250 V

DC Break Capacity	
100W DC resistive	Limited at both 8 A and 250 V
50W DC inductive	

Contact Operational Life	
Maximum contact load:	>10,000 operations

### CB PRE-CLOSING SUPERVISION CONTACT RATING

Carry Continuously	5 A AC or DC
Make & Carry	0.5s 20 A AC or DC
L/R ≤ 40ms & V ≤ 300v	0.2S 30 A AC or DC AC resistive - 1,250 VA AC inductive - 250 VA@ PF≤0.4
Break Capacity	DC resistive - 75W
I ≤ 5 A & V ≤ 300 V	DC inductive - 30W@L/R≤40ms 50W@L/R≤10ms
Maximum contact load:	> 10,000 operations
Minimum recommended load:	0.5W limit 10mA / 5V

## Self-Reset Contact Operation

All contacts operate when a voltage in the specified range is applied to the relay coil and reset when this voltage is removed.

## Coil Operation LED

An optional front panel LED may be specified to indicate when a voltage is applied to the operate coil terminals. This feature can be useful during commissioning particularly for latching relays and where armature flags are not fitted to indicate the operate voltage status. Refer ordering code section.

## Contact Function

### SELF-CLEANING CONTACTS

Contacts are constructed from silver / copper alloy, specially shaped and positioned to ensure very reliable, low resistance operation. Over travel of the contacts during each operation causes a wiping action ensuring a clean 'make' with minimal bounce.

### Double Make / Double Break Contacts

Each contact is made up of a double make or double break geometry to increase the isolation between open contacts and increase the current break rating.

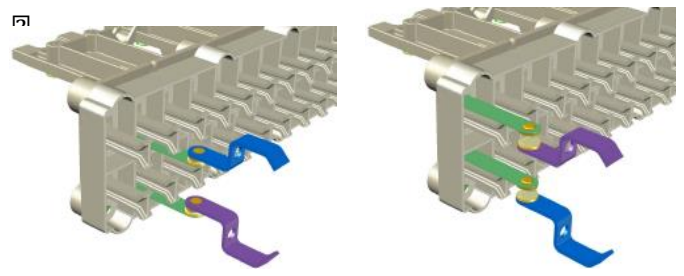

Double 'make' contacts  
picked up

Double 'break' contacts  
picked up

Figure 13: Contact geometry

This geometry also removes the need for internal wiring between case terminals and the relay contacts. This results in four (4) less electrical terminations per contact providing increased system security.

### Gold Plated Contacts

Gold plated contacts are available as an option for very low current switching. Refer ordering code section.

## Flag Indicators

The Alpha XR relay offers two types of mechanical flags. These consist of a high visibility; solid, day glow orange indicator which become visible to indicate an alarm condition. The relay can be ordered with either, both or no flags fitted.

### HAND RESET REVERSE ACTING FLAG

Operation: On coil de-energisation.

Reset: Hand reset.

Note that this flag can only be reset once the relay has been reset under healthy supervision conditions.

### SELF RESET ARMATURE FLAG

Operation: On coil de-energisation.

Reset: Self-reset when alarm condition is cleared.

The armature flag is connected to the relay armature and therefore always indicates the position of the contacts. The standard armature flag becomes visible when the relay is dropped out to signal an alarm condition.

## Insulation

Standard	IEC 60255-5	
Type	Level 3	
Any Terminal and Earth	2.0kV ac rms for 1min	
	5.0kV 1.2/50us 0.5J	
Between Independent Circuits	2.0kV ac rms for 1min	
	5.0kV 1.2/50us 0.5J	
Across Normally Open Contacts	1.0kV ac rms for 1min	

## High Frequency Disturbance

Standard	IEC 60255-22-1	
Type	Level	Variation
Common (Longitudinal)	2.5kV	≤5%
Differential (Transverse)	1.0kV	≤5%

## Electrostatic Discharge

Standard	IEC 60255-22-2 Class 3	
Type	Level	Variation
Air Discharge	8.0kV	≤5%

## Fast Transients

Standard	IEC 60256-5 Class A	
Type	Level	Variation
5/50ns 5kHz	4.0kV	≤5%

## Surge Immunity

Standard	IEC 60255-22-5	
Type	Level	Variation
Line to Earth	4.0kV	≤10%
Line to Line	2.0kV	

## Temperature

Standard	IEC 60068-2-1/2
Operating Range	-10 to +55 degrees Celsius
Storage Range	-25 to +70 degrees Celsius

## Humidity

Standard	IEC 60068-2-78
Operating Range	40 degrees Celsius and 93% RH non condensing

## IP Rating

Standard	IEC 60529
Installed	IP5x

## Vibration - Sinusoidal

Standard	IEC 60255-21-1 Class I	
Vibration Response	0.5gn	≤5%
Vibration Endurance	1.0gn	≤5%

## Shock and Bump

Standard	IEC 60255-21-2 Class I	
Shock Response	5gn, 11ms	≤5%
Shock Withstand	15gn, 11ms	≤5%
Bump Test	10gn, 16ms	≤5%

## Seismic

Standard	IEC 60255-21-3 Class I	
Seismic Response	1gn	≤5%

## Mechanical Classification

Durability - 0.1 Hz maximum repetition rate	>10 <sup>5</sup> operations at no load
	>10 <sup>4</sup> operations at full load

# Case Dimensions 2M28-S

## M Series Draw Out Case

The M Series case range has been specifically designed to meet the demanding and varied requirements for applications in power utility sub-station environments. The standard 4U high 19-inch rack mounting modular configuration simplifies panel design and installation.

Mounting points and overall panel dimensions meet international standards such that the cases may be interchanged with other similar types available on the market.

The following standard features are provided:

- > Compact size 2M28-S case
- > Rack and flush mounting
- > Draw out relay module
- > Rear M4 screw terminals

Refer to the M Series Technical Bulletin for additional information on case mounting and wiring.

## Case Construction

The outer case is manufactured from zinc coated mild steel providing considerable strength and long term durability. The entire case surface is powder coated to provide corrosion protection and an attractive textured finish. Relay elements are mounted on fabricated fiberglass and acetal components to provide reliable electrical isolation and simple cost effective construction.

## Terminal Ratings

20A continuous

200A 1 s

## Terminal Block

The draw out function is made possible through the use of inner and outer terminal blocks, each with silver plated contact fingers to provide high current rating and very low electrical resistance.

A high quality molded inner terminal block is utilized which incorporates the switching contacts thus eliminating the requirement for internal wiring and in turn removing a potential circuit failure mechanism.

M4 screw terminals allow 2x crimp lug connections per point. Space efficient design allows 28 contact points per terminal block.

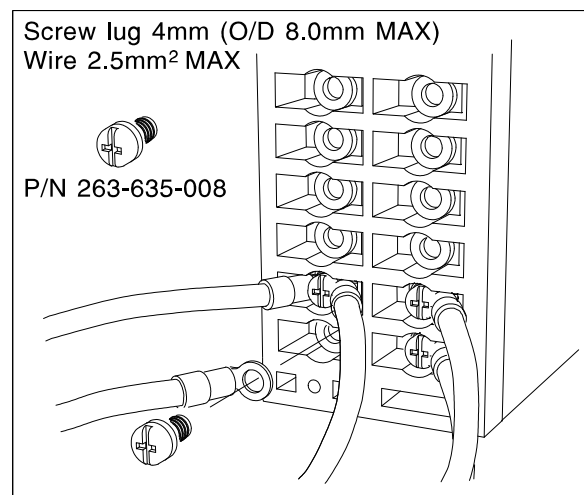

Figure 14: Rear terminal wiring configuration

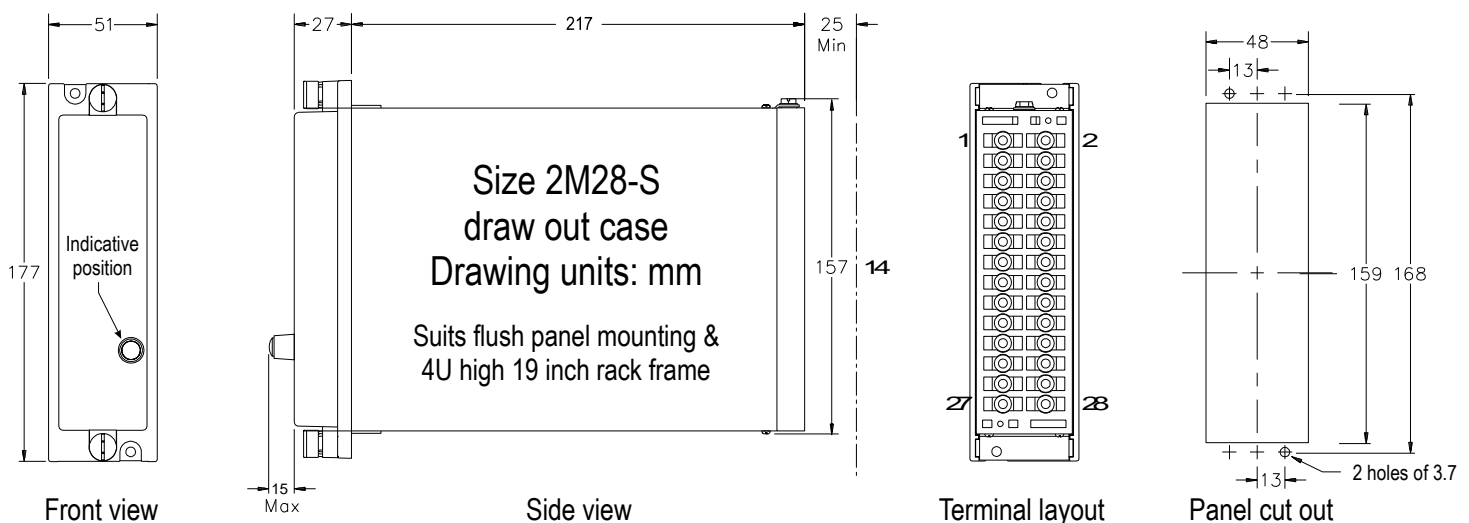

Figure 15: Alpha case details

## Standard Wiring Configuration

The case termination diagram in figure 16 depicts the rear screw terminals and position of the five (5) output contacts.

The contact function between each pairs of terminals is determined by the order code selected.

**M** Normally open Make (M) contact

This contact closes when the relay operate coil is energized.

**B** Normally closed Break (B) contact

This contact opens when the relay operate coil is energized.

Table 1 provides the terminal wiring assignment for each of the contact configurations available with the XR5 relay version.

Refer to the application diagrams in figures 2 to 12 for other circuit connections to the case terminals.

This wiring table is also printed on the side panel of the draw out module for easy reference in the field.

Contact Configuration	XR5 Case Terminal Number Pairs				
	17-18	19-20	21-22	23-24	25-26
N	5M+0B	M	M	M	M
P	4M+1B	M	M	M	B
Q	3M+2B	B	M	M	B
R	2M+3B	B	M	M	B
S	1M+4B	B	B	M	B

Table 1: Contact configuration and connection chart for the XR5

## Circuit Breaker Pre-Closing Supervision Contact

The XR5-00-6 Trip Circuit Supervision version has an additional C/O make (M), PCS contact across terminals 9, 11 and 12.

## XR5 Case Terminals

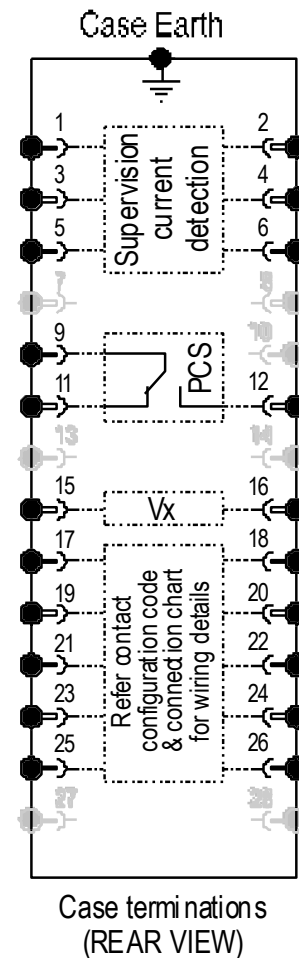

Figure 16: Generic rear terminal layout for the XR5  
 PCS shown in de-energized condition  
 Refer wiring diagrams in figures 2-12



## Alpha XR Relay Order Code

XR5 -							
Nominal Operate Voltage	B					32 V DC	
	C					48 V DC	
	D					110 V DC	
	E					125 V DC	
	F					220 V DC	
	G					240 V DC	
	H					250 V DC	
Alarm Contact Configuration	N					5M + 0B	
- Refer Table 1	P					4M + 1B	
	Q					3M + 2B	
	R					2M + 3B	
	S					1M + 4B	
Supervision Function		1				Trip relay coil supervision	
		4				Trip supply supervision	
		6				Single pole trip circuit supervision	
Flag Indication			1			No flags fitted	
			4			Both flags fitted	Refer order codes 5 and 6
			5			Reverse acting self-reset armature flag	Flag visible in alarm condition
			6			Reverse acting hand reset flag	Flag visible in alarm condition
Options				-		None	
				L		Supervision Healthy Green LED	
Non-standard parameters					-	None	
					-IP2X	With IP2X terminal cover	

Refer to Appendix 1 for further detail on IP2X terminal covers.

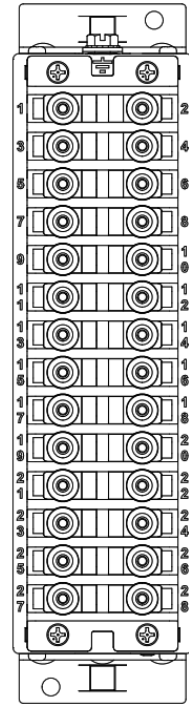
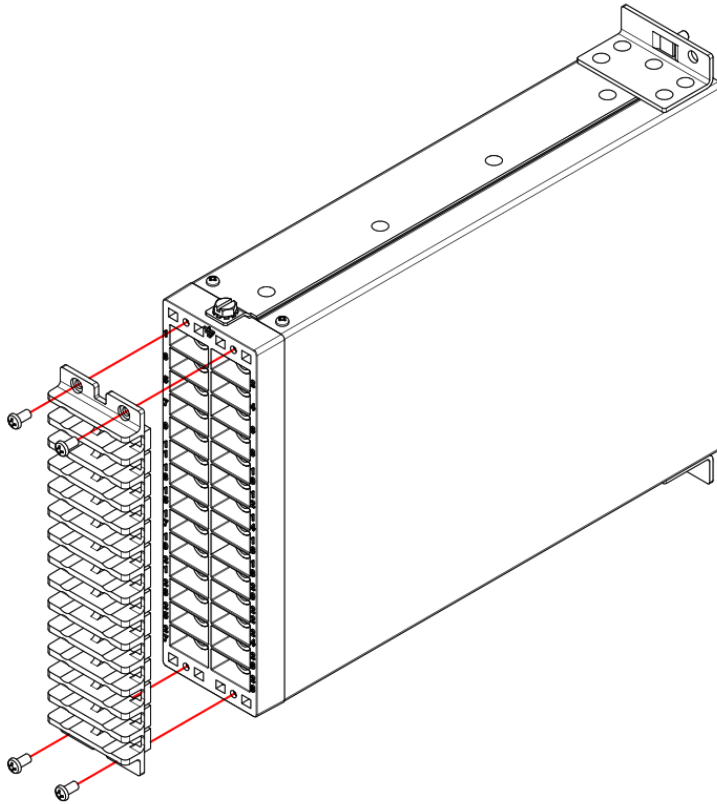

2M28-S Case with IP2X cover

Note: IP2X terminal covers are fitted prior to relay wiring termination.



**RMS Mors Smitt**

A *Wabtec* Company

---

**RMS Mors Smitt**  
19 Southern Court  
Keysborough, VIC 3173, Australia  
Tel: +61 (0)3 8544 1200  
sales.rms@wabtec.com

**Wabtec Netherlands B.V.**  
Darwinstraat 10  
6718 XR Ede, Netherlands  
Tel: +31 (0)88 600 4500  
sales.msbv@wabtec.com



**RMS Mors Smitt**

A *Wabtec* Company



Visit [www.morssmitt.com/rms](http://www.morssmitt.com/rms) for the latest product information.  
Due to RMS continuous product improvement policy this information is subject to change without notice

