



# Voltage regulator TAPCON<sup>®</sup> 230 AVT

## Operating instructions

7820299/03 EN



© All rights reserved by Maschinenfabrik Reinhausen

Dissemination and reproduction of this document and use and disclosure of its content are strictly prohibited unless expressly permitted.

Infringements will result in liability for compensation. All rights reserved in the event of the granting of patents, utility models or designs.

The product may have been altered since this document was published.

We reserve the right to change the technical data, design and scope of supply.

Generally the information provided and agreements made when processing the individual quotations and orders are binding.

The original operating instructions were written in German.



## Table of contents

<b>1</b>	<b>Introduction.....</b>	<b>7</b>
1.1	Manufacturer.....	7
1.2	Completeness.....	7
1.3	Safekeeping.....	7
1.4	Notation conventions.....	7
1.4.1	Hazard communication system.....	7
1.4.2	Information system.....	9
1.4.3	Instruction system.....	9
1.4.4	Typographic conventions.....	10
<b>2</b>	<b>Safety.....</b>	<b>11</b>
2.1	Appropriate use.....	11
2.2	Inappropriate use.....	12
2.3	Fundamental safety instructions.....	12
2.4	Personnel qualification.....	14
2.5	Personal protective equipment.....	15
<b>3</b>	<b>IT security.....</b>	<b>16</b>
3.1	General.....	16
3.2	Operation.....	16
3.3	Commissioning.....	16
3.4	Communication interfaces.....	17
3.5	Encryption standards.....	17
<b>4</b>	<b>Product description.....</b>	<b>19</b>
4.1	Function description of the voltage regulation.....	19
4.2	Scope of delivery.....	19
4.3	Performance features.....	20
4.4	Operating modes.....	21
4.5	Design.....	22
4.5.1	Display, operating elements and front interface.....	22
4.5.2	LEDs.....	23
4.5.3	Front interface.....	24
4.5.4	Connections and fuses.....	25
4.5.5	Nameplate.....	27



4.5.6 Safety markings ..... 27

4.5.7 Visualization ..... 27

**5 Packaging, transport and storage ..... 33**

5.1 Suitability, structure and production ..... 33

5.2 Markings ..... 33

5.3 Transportation, receipt and handling of shipments ..... 33

5.4 Storage of shipments ..... 34

**6 Mounting ..... 35**

6.1 Preparation ..... 35

6.2 Minimum distances ..... 36

6.3 Assembly variants ..... 36

6.3.1 Flush panel mounting ..... 36

6.3.2 Wall mounting with housing (optional) ..... 38

6.4 Connecting device ..... 40

6.4.1 Cable recommendation ..... 40

6.4.2 Electromagnetic compatibility ..... 41

6.4.3 Connecting cables to the system periphery ..... 44

6.4.4 Connecting the CAN bus ..... 44

6.4.5 Connecting SCADA ..... 47

6.4.6 Wiring voltage measurement/current measurement UI ..... 51

6.4.7 Wiring analog inputs AI ..... 52

6.4.8 Wiring digital inputs DI ..... 53

6.4.9 Wiring digital outputs DO ..... 54

6.4.10 Wiring resistor contact series ..... 54

6.4.11 Connecting the power supply ..... 54

6.5 Performing tests ..... 56

**7 Initial steps ..... 57**

7.1 Establishing connection to visualization ..... 57

**8 Commissioning ..... 60**

8.1 Commissioning wizard ..... 60

8.2 Function tests ..... 60

8.2.1 Checking measured values and status of digital inputs and outputs ..... 61

8.2.2 Testing the device control function ..... 61

8.2.3 Checking parallel operation ..... 62



<b>9</b>	<b>Operation.....</b>	<b>67</b>
9.1	System.....	67
9.1.1	General.....	67
9.1.2	Configuring the network.....	69
9.1.3	Setting the device time.....	70
9.1.4	Setting the screensaver.....	72
9.1.5	Configuring syslog.....	73
9.1.6	SCADA.....	74
9.1.7	Linking signals and events.....	75
9.1.8	Configuring digital inputs and outputs.....	78
9.1.9	Event management.....	79
9.1.10	User administration.....	81
9.1.11	Hardware.....	85
9.1.12	Software.....	85
9.1.13	Import/export manager.....	85
9.2	Power grid.....	88
9.2.1	Transformer data.....	88
9.2.2	Voltage monitoring.....	93
9.2.3	Current monitoring.....	95
9.2.4	Power monitoring.....	97
9.2.5	Power flow monitoring.....	99
9.2.6	TAPCON® 2xx retrofit.....	100
9.3	On-load tap-changer regulator.....	102
9.3.1	Voltage regulation.....	102
9.3.2	Parallel operation.....	109
9.3.3	U bandwidth monitoring.....	118
9.4	On-load tap-changer.....	120
9.4.1	Tap position monitoring.....	120
9.4.2	Tap position capture method.....	121
9.4.3	Target-tap-position operation.....	123
9.4.4	OLTC data.....	123
9.4.5	Information about the on-load tap-changer.....	123
9.5	Motor-drive unit and control cabinet.....	124
9.5.1	Control of the motor-drive unit.....	124
<b>10</b>	<b>Maintenance and care.....</b>	<b>127</b>
10.1	Cleaning the device.....	127



10.2	Updating application software.....	127
10.2.1	Copy the application software to the PC.....	127
10.2.2	Establishing connection to visualization.....	128
10.2.3	Updating application software.....	129
<b>11</b>	<b>Fault elimination.....</b>	<b>131</b>
11.1	General faults.....	131
11.2	No regulation in AUTO mode.....	131
11.3	Human-machine interface.....	132
11.4	Incorrect measured values.....	132
11.5	Parallel operation faults.....	133
11.6	Tap position capture incorrect.....	134
11.7	Other faults.....	134
<b>12</b>	<b>Disposal.....</b>	<b>135</b>
<b>13</b>	<b>Technical data.....</b>	<b>136</b>
13.1	Display elements.....	136
13.2	Materials.....	136
13.3	Dimensions.....	136
13.4	Power supply.....	136
13.5	Voltage measurement and current measurement.....	137
13.6	Central processing unit.....	138
13.7	Digital inputs.....	140
13.8	Digital outputs.....	141
13.9	Analog inputs.....	143
13.10	Communication interfaces.....	145
13.11	Tap position capture / resistor contact series.....	147
13.12	Ambient conditions.....	147
13.13	Standards and directives.....	147
13.14	Connection diagrams.....	149
	TAPCON® 230 AVT.....	150
	<b>Glossary.....</b>	<b>153</b>



## 1 Introduction

This technical file contains detailed descriptions on the safe and proper installation, connection, commissioning and monitoring of the product.

It also includes safety instructions and general information about the product.

This technical file is intended solely for specially trained and authorized personnel.

### 1.1 Manufacturer

The product is manufactured by:

Maschinenfabrik Reinhausen GmbH

Falkensteinstraße 8  
93059 Regensburg  
Tel.: (+49) 9 41/40 90-0  
E-mail: sales@reinhausen.com

Further information on the product and copies of this technical file are available from this address if required.

### 1.2 Completeness

This technical document is incomplete without the following supporting documents:

- Connection diagrams
- Operating Instructions
  - Available as a download on the device
  - Available for download at [www.reinhausen.com](http://www.reinhausen.com)
  - Available for download in the MR Customer Portal

### 1.3 Safekeeping

Keep this technical document and all supporting documents ready at hand and accessible for future use at all times. Download the operating instructions from the device. The operating instructions are also available on the Maschinenfabrik Reinhausen GmbH website and in the MR Customer Portal.

### 1.4 Notation conventions

#### 1.4.1 Hazard communication system

Warnings in this technical file are displayed as follows.

### 1.4.1.1 Warning relating to section

Warnings relating to sections refer to entire chapters or sections, sub-sections or several paragraphs within this technical file. Warnings relating to sections use the following format:

**▲ WARNING**



#### Type of danger!

Source of the danger and outcome.

- ▶ Action
- ▶ Action

### 1.4.1.2 Embedded warning information

Embedded warnings refer to a particular part within a section. These warnings apply to smaller units of information than the warnings relating to sections. Embedded warnings use the following format:

**▲ DANGER!** Instruction for avoiding a dangerous situation.

### 1.4.1.3 Signal words and pictograms

The following signal words are used:

Signal word	Definition
DANGER	Indicates a hazardous situation which, if not avoided, will result in death or serious injury.
WARNING	Indicates a hazardous situation which, if not avoided, could result in death or serious injury.
CAUTION	Indicates a hazardous situation which, if not avoided, could result in minor or moderate injury.
NOTICE	Indicates measures to be taken to prevent damage to property.

Table 1: Signal words in warning notices

Pictograms warn of dangers:





Pictogram	Definition
	Warning of a danger point
	Warning of dangerous electrical voltage
	Warning of combustible substances
	Warning of danger of tipping
	Warning of danger of crushing

Table 2: Pictograms used in warning notices

### 1.4.2 Information system

Information is designed to simplify and improve understanding of particular procedures. In this technical file it is laid out as follows:



Important information.

### 1.4.3 Instruction system

This technical file contains single-step and multi-step instructions.

#### Single-step instructions

Instructions which consist of only a single process step are structured as follows:



- Aim of action
- ✓ Requirements (optional).
- ▶ Step 1 of 1.
  - ⇒ Result of step (optional).
- ⇒ Result of action (optional).

**Multi-step instructions**

Instructions which consist of several process steps are structured as follows:

- Aim of action
- ✓ Requirements (optional).
- 1. Step 1.
  - ⇒ Result of step (optional).
- 2. Step 2.
  - ⇒ Result of step (optional).
- ⇒ Result of action (optional).

**1.4.4 Typographic conventions**

Typographic convention	Purpose	Example
UPPERCASE	Operating controls, switches	ON/OFF
[Brackets]	PC keyboard	[Ctrl] + [Alt]
<b>Bold</b>	Software operating controls	Press <b>Continue</b> button
...>...>...	Menu paths	Parameter > Control parameter
<i>Italics</i>	System messages, error messages, signals	<i>Function monitoring</i> alarm triggered
[▶ Number of pages]	Cross reference	[▶ Page 41].
<u>Dotted underscore</u> .....	Glossary entry, abbreviations, definitions, etc.	<u>Glossary entry</u> .

Table 3: Typographic conventions used in this technical file



## 2 Safety

- Read this technical file through to familiarize yourself with the product.
- This technical file is a part of the product.
- Read and observe the safety instructions provided in this chapter.
- Read and observe the warnings in this technical file in order to avoid function-related dangers.
- The product is manufactured on the basis of state-of-the-art technology. Nevertheless, risks to life and limb for the user or impairment of the product and other material assets due to the function may arise in the event of improper use.

### 2.1 Appropriate use

The device keeps the output voltage of a transformer with an on-load tap-changer constant. The product is designed solely for use in stationary large-scale electrical energy systems and facilities.

If used as intended, in compliance with the requirements and conditions specified in this technical document and observing the warning notices in this technical document and attached to the product, the product does not pose a risk of injury or damage to property or the environment. This applies throughout the service life of the product, from delivery, installation and operation to removal and disposal.

The following is considered intended use:

- You will find the standard valid for the product and the year of issue on the nameplate.
- Operate the product in accordance with this technical document, the agreed-upon delivery conditions and the technical data.
- Ensure that all necessary work is performed by qualified personnel only.
- Only use the equipment and special tools included in the scope of delivery for the intended purpose and in accordance with the specifications of this technical document.
- Only operate the product in industrial areas.
- Observe the notices in this technical document regarding electromagnetic compatibility and the technical data.
- The product is intended for installation. Make sure that all fire safety precautions and protection against electric shock are met.
- Make sure that the resistance to mechanical stress is met.



## 2.2 Inappropriate use

Use is considered to be inappropriate if the product is used other than as described in the Intended use section. In addition, observe the following:

- The product is not a protective device. Do not use it to handle safety-related functions.
- Do not operate the product in potentially explosive areas.

## 2.3 Fundamental safety instructions

To prevent accidents, malfunctions and damage as well as unacceptable adverse effects on the environment, those responsible for transport, installation, operation, maintenance and disposal of the product or parts of the product must ensure the following:

### Personal protective equipment

Loosely worn or unsuitable clothing increases the danger of becoming trapped or caught up in rotating parts and the danger of getting caught on protruding parts. This poses a danger to life and limb.

- Wear appropriate personal protective equipment such as a helmet, work gloves, etc. for the respective activity.
- Never wear damaged personal protective equipment.
- Never wear rings, necklaces, or other jewelry.
- If you have long hair, wear a hairnet.

### Work area

Untidy and poorly lit work areas can lead to accidents.

- Keep the work area clean and tidy.
- Make sure that the work area is well lit.
- Observe the applicable laws for accident prevention in the relevant country.

### Working during operation

The product may only be operated in a sound, operational condition. Otherwise it poses a danger to life and limb.

- Regularly check the operational reliability of safety equipment.
- Comply with the inspection work, maintenance work and maintenance intervals described in this technical file.



### **Invisible laser radiation**

Looking directly into the beam or the reflected beam can cause eye damage. The beam is emitted at the optical connections or at the end of the fiber-optic cables connected to them on the assemblies. Read the chapter "Technical Data" [► Section 13, Page 136] for further information.

- Never look directly into the beam or the reflected beam.
- Never look into the beam with the aid of optical instruments such as a magnifying glass or a microscope.
- In the event that the laser beam strikes your eyes, close your eyes immediately and move your head out of the path of the beam.

### **Working with current transformers**

Dangerous high voltages may occur when a current transformer is operated with an open secondary circuit. This can lead to injuries and property damage.

- Never operate a current transformer with an open secondary circuit; short-circuit the current transformer to prevent this.
- Observe the information in the current transformer operating instructions.

### **Handling electrical components**

Electrical components can be damaged by electrostatic discharge.

- Never touch electrical components during commissioning, operation or maintenance work.
- Take suitable measures (such as covers) to ensure that personnel cannot touch components.
- Wear suitable personal protective equipment.

### **Explosion protection**

Highly flammable or explosive gases, vapors and dusts can cause serious explosions and fire.

- Do not install or operate the product in areas where a risk of explosion is present.

### **Safety markings**

Warning signs and safety information plates are safety markings on the product. They are an important aspect of the safety concept.

- Observe all safety markings on the product.
- Make sure all safety markings on the product remain intact and legible.
- Replace safety markings that are damaged or missing.



### **Ambient conditions**

To ensure reliable and safe operation, the product must only be operated under the ambient conditions specified in the technical data.

- Observe the specified operating conditions and requirements for the installation location.

### **Modifications and conversions**

Unauthorized or inappropriate changes to the product may lead to personal injury, material damage and operational faults.

- Only modify the product after consultation with Maschinenfabrik Reinhausen GmbH.

### **Spare parts**

Spare parts not approved by Maschinenfabrik Reinhausen GmbH may lead to physical injury, damage to the product and malfunctions.

- Only use spare parts that have been approved by Maschinenfabrik Reinhausen GmbH.
- Contact Maschinenfabrik Reinhausen GmbH.

## **2.4 Personnel qualification**

The person responsible for assembly, commissioning, operation, maintenance and inspection must ensure that the personnel are sufficiently qualified.

### **Electrically skilled person**

The electrically skilled person has a technical qualification and therefore has the required knowledge and experience, and is also conversant with the applicable standards and regulations. The electrically skilled person is also proficient in the following:

- Can identify potential dangers independently and is able to avoid them.
- Is able to perform work on electrical systems.
- Is specially trained for the working environment in which (s)he works.
- Must satisfy the requirements of the applicable statutory regulations for accident prevention.

### **Electrically trained persons**

An electrically trained person receives instruction and guidance from an electrically skilled person in relation to the tasks undertaken and the potential dangers in the event of inappropriate handling as well as the protective devices and safety measures. The electrically trained person works exclusively under the guidance and supervision of an electrically skilled person.



### Operator

The operator uses and operates the product in line with this technical file. The operating company provides the operator with instruction and training on the specific tasks and the associated potential dangers arising from improper handling.

### Technical Service

We strongly recommend having maintenance, repairs and retrofitting carried out by our Technical Service department. This ensures that all work is performed correctly. If maintenance is not carried out by our Technical Service department, please ensure that the personnel who carry out the maintenance are trained and authorized by Maschinenfabrik Reinhausen GmbH to carry out the work.

### Authorized personnel

Authorized personnel are trained by Maschinenfabrik Reinhausen GmbH to carry out special maintenance.

## 2.5 Personal protective equipment

Personal protective equipment must be worn during work to minimize risks to health.

- Always wear the personal protective equipment required for the job at hand.
- Never wear damaged personal protective equipment.
- Observe information about personal protective equipment provided in the work area.

<b>Protective clothing</b>	Close-fitting work clothing with a low tearing strength, with tight sleeves and with no protruding parts. It mainly serves to protect the wearer against being caught by moving machine parts.
<b>Safety shoes</b>	To protect against falling heavy objects and slipping on slippery surfaces.
<b>Safety glasses</b>	To protect the eyes from flying parts and splashing liquids.
<b>Visor</b>	To protect the face from flying parts and splashing liquids or other dangerous substances.
<b>Hard hat</b>	To protect against falling and flying parts and materials.
<b>Hearing protection</b>	To protect against hearing damage.
<b>Protective gloves</b>	To protect against mechanical, thermal, and electrical hazards.

Table 4: Personal protective equipment



## 3 IT security

Observe the following recommendations to operate the product safely.

### 3.1 General

- Ensure that only authorized personnel have access to the device.
- Only use the device within an ESP (electronic security perimeter). Do not connect the device to the Internet in an unprotected state. Use mechanisms for vertical and horizontal network segmenting and security gateways (firewalls) at the transition points.
- Ensure that the device is only operated by trained personnel who are familiar with IT security.

### 3.2 Operation

Observe the following recommendations during device operation:

- Change the password at regular intervals.
- Export the security log [► Section 9.1.13.1, Page 85] at regular intervals.
- Check the log files regularly for unauthorized system access and other security-related events.

### 3.3 Commissioning

Observe the following recommendations for device commissioning:

- User IDs must be unique and assignable. Do not use a "Group account" function or the "Auto login" function.
- Activate the "Auto logout [► Section 9.1.1.2, Page 68]" function.
- Restrict the rights of the individual user groups as much as is feasible; this helps avoid errors during operations. A user with the "Operator" role, for example, should only perform operations and should not be able to change any device settings.
- Delete or disable the default "admin" user ID. This requires first creating a new user account with the "Administrator" role. You can then use it to delete or disable the default "admin" account.
- Deactivate service user access [► Section 9.1.1.3, Page 68].
- Enable SSL/TLS encryption [► Page 70]; access to the device is then only possible using the SSL/TLS protocol. In addition to encrypting communication, this protocol also checks the authenticity of the server.
- Use TLS version 1.2 or higher wherever possible.
- Integrate the device into a public key infrastructure. Create your own SSL certificates for this if necessary and then import them.
- Connect the device to a central log server by using the syslog interface [► Section 9.1.5, Page 73].



### 3.4 Communication interfaces

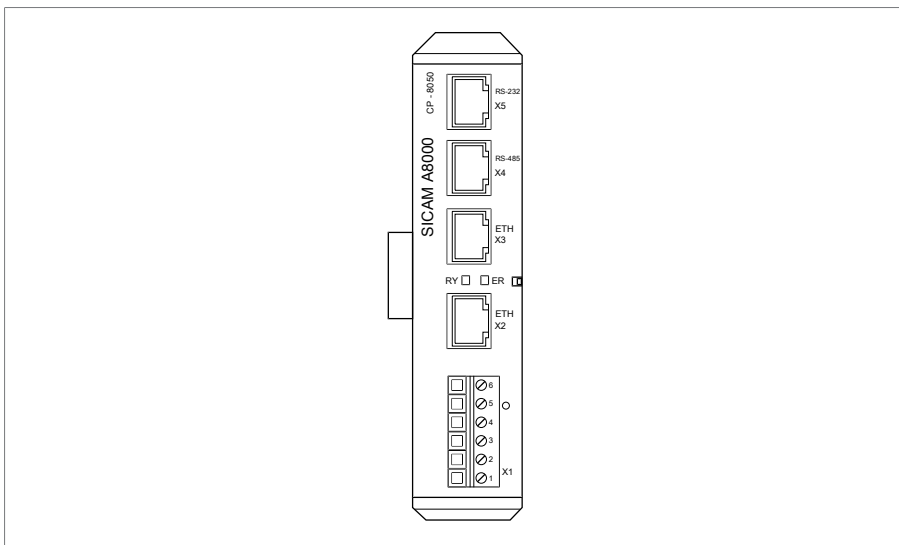

Figure 1: Interfaces: CPU

Interface	Protocol	Port	Description
X2	TCP	102	IEC 61850
X2	TCP	502	Modbus <sup>1)</sup>
X2	TCP	20000	DNP3 <sup>1)</sup>
X2	TCP	2404	IEC 60870-5-104 1)
X3	TCP	80	HTTP for web-based visualization <sup>2)</sup>
X3	TCP	443	HTTPS for web-based visualization
X3	TCP	22	SSH server <sup>3)</sup>
X4	-	-	Serial interface (SCADA)
X5	-	-	Serial interface (SCADA)

Table 5: Interfaces and open ports of the CPU assembly

<sup>1)</sup> Default setting; if you have modified the port for the control system protocol, only the set port is open.

<sup>2)</sup> Port is closed if you activate the device's SSL encryption.

<sup>3)</sup> SSH is disabled when MR service access is disabled.

### 3.5 Encryption standards

The device supports the following TLS versions:

- TLS 1.0
- TLS 1.1
- TLS 1.2



The device uses the following cipher suites for a TLS-secured connection:

	Key exchange	Authentication		Encryption	Key length	Operating mode	Hash function	
TLS	ECDHE	RSA	WITH	AES	128	CBC	SHA	
	DHE						SHA265	
	ECDHE	ECDSA				GCM	SHA256	
	ECDH						256	CBC
						RSA		GCM
							SHA384	

Table 6: Cipher suite

The device uses the SHA512 hash function to save passwords.



## 4 Product description

### 4.1 Function description of the voltage regulation

The device keeps the output voltage of a transformer with an on-load tap-changer constant.

The device compares the transformer's measured voltage ( $U_{actual}$ ) with a defined reference voltage ( $U_{desired}$ ). The difference between  $U_{actual}$  and  $U_{desired}$  is the control deviation  $dU$ .

The device parameters can be adjusted to the line voltage behavior to achieve a balanced control response with the on-load tap-changer only performing a small number of tap-change operations.

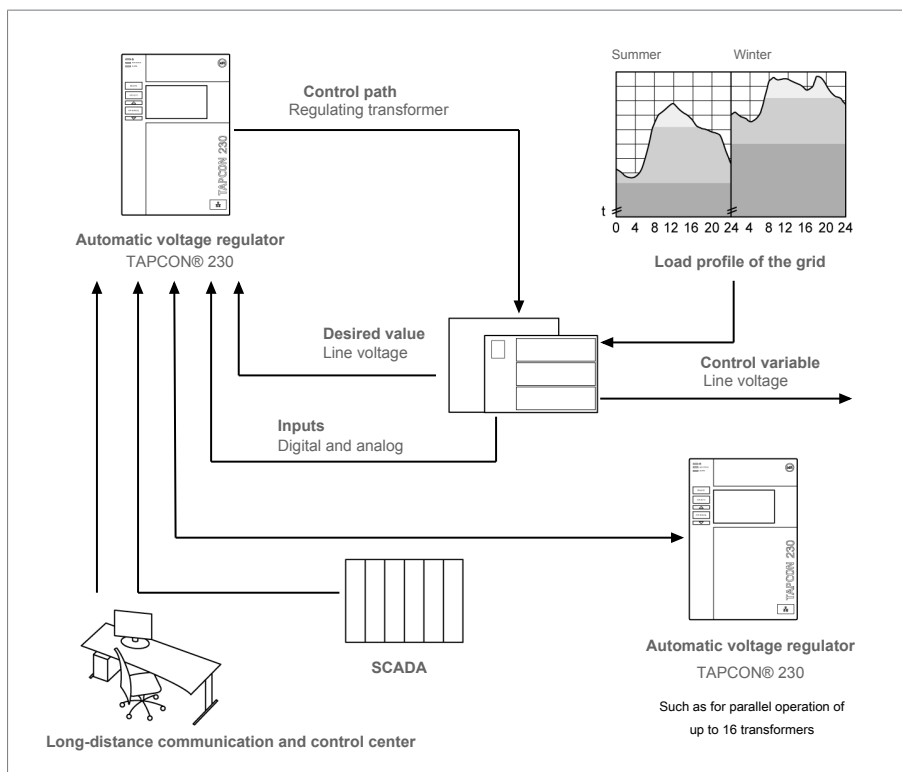

Figure 2: Overview of voltage regulation

### 4.2 Scope of delivery

Check the shipment for completeness based on the shipping documents.

- Voltage regulator
- RJ45 patch cables
- Shield clamps
- Plug connectors
- Tension clamps



- Technical documents
- Additional nameplate
- Terminating resistor for CAN bus
- Terminating resistor for RS485 bus

### Optional

- Housing for wall mounting
- Device type-dependent:
  - Ethernet to FO converter (SFP module)
  - Serial to FO converter

### 4.3 Performance features

- Web-based visualization
- Automatic voltage regulation
  - 1 to 3 desired values
- Desired value setting
  - Analog
  - Using TDSC
- Integrated monitoring functions:
  - Voltage monitoring
  - Current monitoring
  - Apparent power monitoring
  - Active power monitoring
  - Reactive power monitoring
  - Power factor monitoring
- Display of all measured values such as voltage, current, active power, apparent power and reactive power
- Tap position capture
  - BCD code
  - Dual code
  - Gray code
  - Resistor contact series
  - N/O contact series
  - Analog
- Parallel operation of up to 16 transformers in 2 groups using the following methods:
  - Master (tap synchronization)
  - Follower (tap synchronization)
  - Automatic tap synchronization



- Circulating reactive current
- Power factor
- SCADA
  - Modbus RTU
  - Modbus TCP

#### 4.4 Operating modes

##### Auto mode (AVR AUTO)

In auto mode, the device automatically regulates the voltage in accordance with the set parameters. It is not possible to perform manual tap-change operations using operating controls or inputs.

##### Manual mode (AVR MANUAL)

In manual mode, you can perform manual tap-change operations to increase or decrease the voltage. There is no automatic voltage regulation.

##### Local mode (LOCAL)

In local mode, you can make entries and issue commands using the device's operating controls. You cannot use inputs to make entries or issue commands.

##### Remote mode (REMOTE)

In remote mode, you can make entries and issue commands using digital inputs.

	AVR AUTO		AVR MANUAL	
	LOCAL	REMOTE	LOCAL	REMOTE
Automatic regulation	Yes	Yes	No	No
Tap-change operation via operating controls	No	No	Yes	No
Tap-change operation via inputs	No	No	No	Yes
Tap-change operation via SCADA <sup>1)</sup>	No	No	No	Yes
Value adjustment via SCADA <sup>1)</sup>	No	Yes	No	Yes

Table 7: Overview of operating modes

<sup>1)</sup> Only with the TAPCON® 230 expert and TAPCON® 230 AVT versions

## 4.5 Design

### 4.5.1 Display, operating elements and front interface

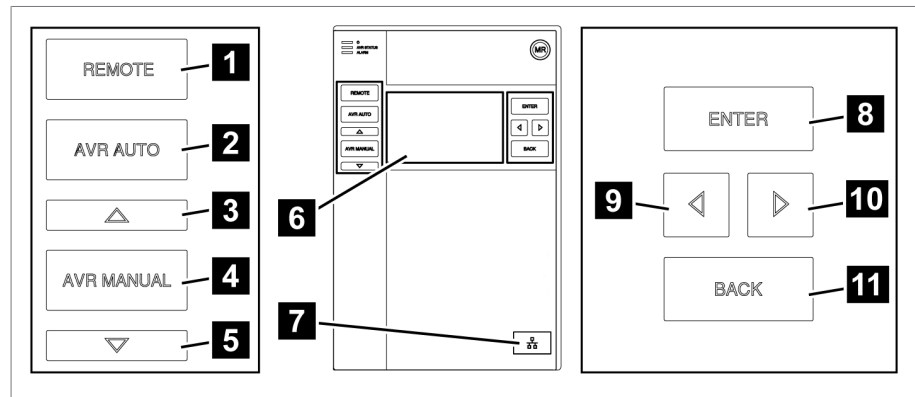

Figure 3: Voltage regulator

1	REMOTE key <sup>1</sup>	Activate REMOTE mode
2	AUTO key	Activate AUTO mode
3	RAISE key <sup>2</sup>	Send a control command to the motor-drive unit to increase the voltage.
4	MANUAL key	Activate MANUAL mode
5	LOWER key <sup>2</sup>	Send a control command to the motor-drive unit to reduce the voltage.
6	Display	-
7	Front interface	RJ45 Ethernet interface
8	ENTER key	Confirm selection/save modified parameters
9	LEFT cursor	Navigate to the left in the menu
10	RIGHT cursor	Navigate to the right in the menu
11	BACK key	Exit the current menu. Return to the previous menu level

<sup>1</sup> Key without function if a digital input is used to toggle between LOCAL/REMOTE.

<sup>2</sup> Only possible in manual mode.



4.5.2 LEDs

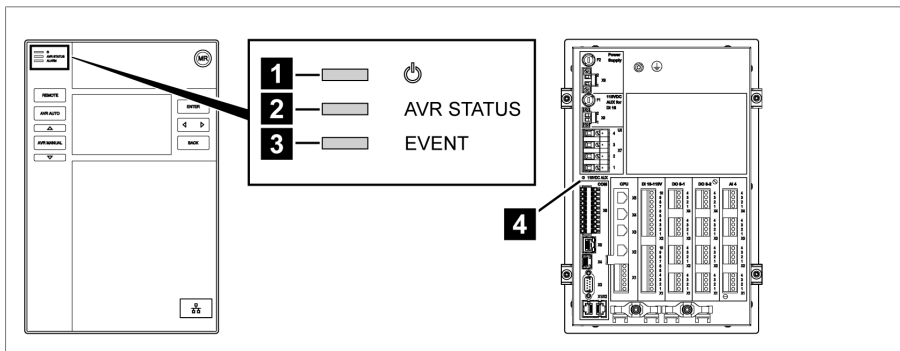

Figure 4: LEDs

1	<i>Power supply LED</i>	Blue	Illuminates when the device is supplied with power.
2	<i>AVR STATUS LED</i>	Red	Illuminates when the device is in the error state.
		Yellow	Illuminates when the device starts or has been paused; e.g. during a software update.
		Blue	Illuminates when the device is in the operating state.
3	<i>ALARM LED</i>	Red	Illuminates as soon as a red event is present.
		Yellow	Illuminates as soon as a yellow event is present.
		Blue	Illuminates if there are no events or a gray event is present.
4	<i>LED X8 110 V DC output</i>	Blue	Illuminates when the digital inputs are supplied with power.

### 4.5.3 Front interface

The parameters for the device can be set using a PC on site. The RJ45 Ethernet interface, which can be found under the interface cover, is provided for this purpose. To establish a connection with the device, refer to the Visualization section in the operating instructions.

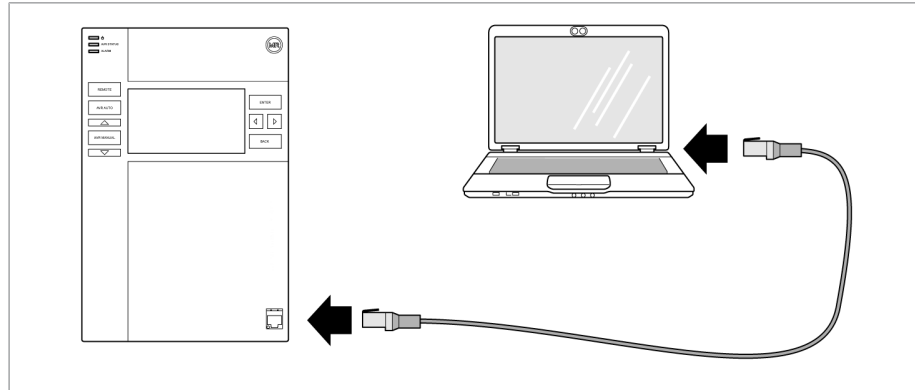

Figure 5: Device connection to a PC



### 4.5.4 Connections and fuses

The connections are located on the rear of the device. You will find more information on the connections in the Technical data [► Section 13, Page 136] section.

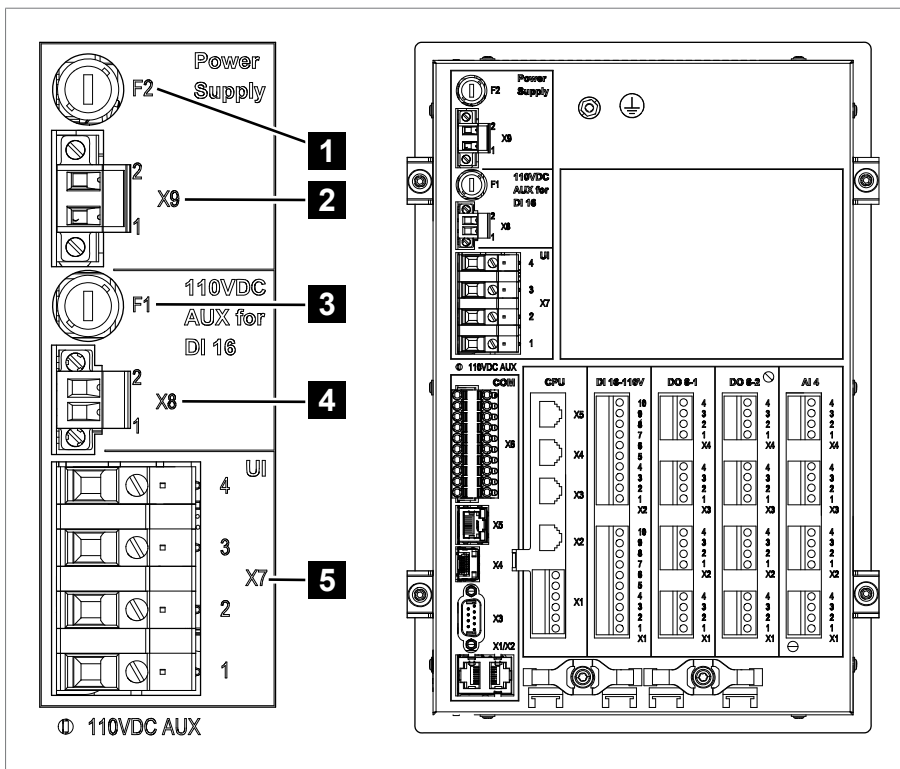

Figure 6: Rear

1	F2	Internal fuse for the power supply	2	X9	Power supply
3	F1	Internal fuse for 110 V DC (digital inputs)	4	X8	Auxiliary supply voltage 110 V DC for digital inputs
5	X7	Voltage measurement/ current measurement			

Connections and terminals

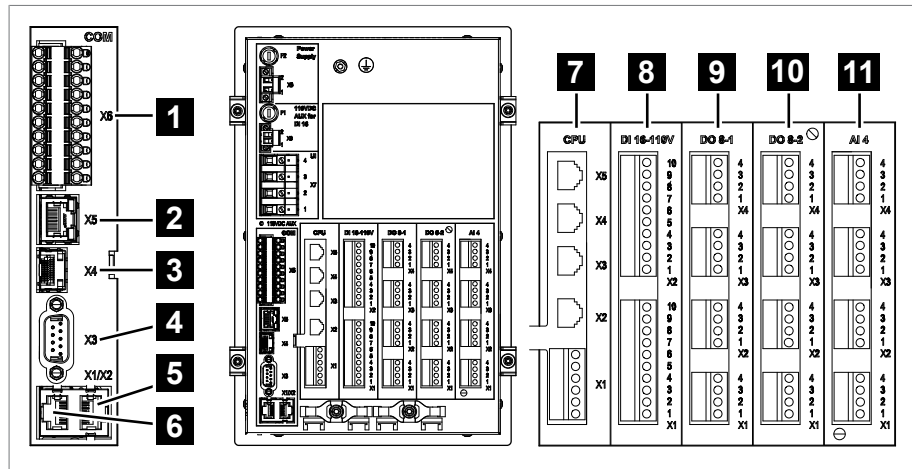

Figure 7: Connections/terminals

1	COM-X6	CAN bus <sup>1)</sup> /SCADA interface RS485 <sup>2)</sup> /resistor contact series	2	COM-X5	Interface for patch cable for SCADA via fiber-optic cable
3	COM-X4	Fiber-optic cable <sup>2)</sup> (SFP cage for the SFP module)	4	COM-X3	SCADA interface RS232 <sup>2)</sup>
5	COM-X2	Interface for visualization via the front interface	6	COM-X1	Interface for patch cable for RS232 or RS485
7	CPU	Central processing unit	8	DI 16-110V	Digital inputs
9	DO 8-1	Digital outputs <sup>1)</sup>	10	DO 8-2	Digital outputs <sup>1)</sup>
11	AI 4	Analog inputs <sup>1)</sup>			

<sup>1)</sup>Only for the Pro, Expert and AVT variants.

<sup>2)</sup>Only for Expert variant.



### 4.5.5 Nameplate

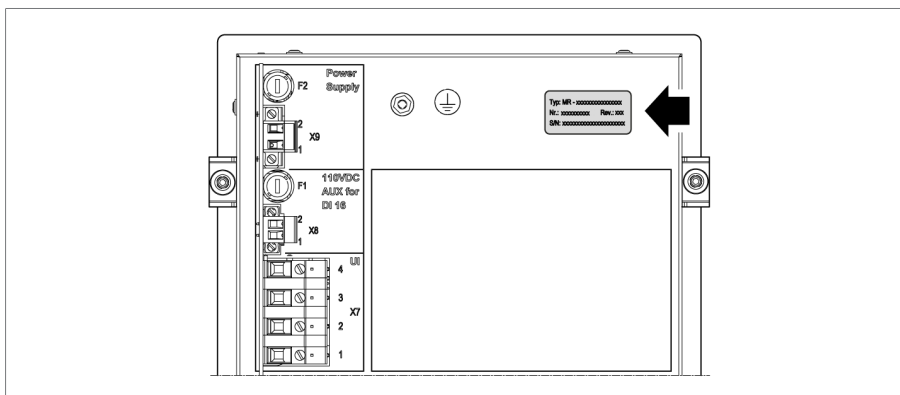

Figure 8: Nameplate on the rear of the device

### 4.5.6 Safety markings



Warning of a danger point. Read the information given in the product operating instructions.

### 4.5.7 Visualization

#### 4.5.7.1 Main screen

Home

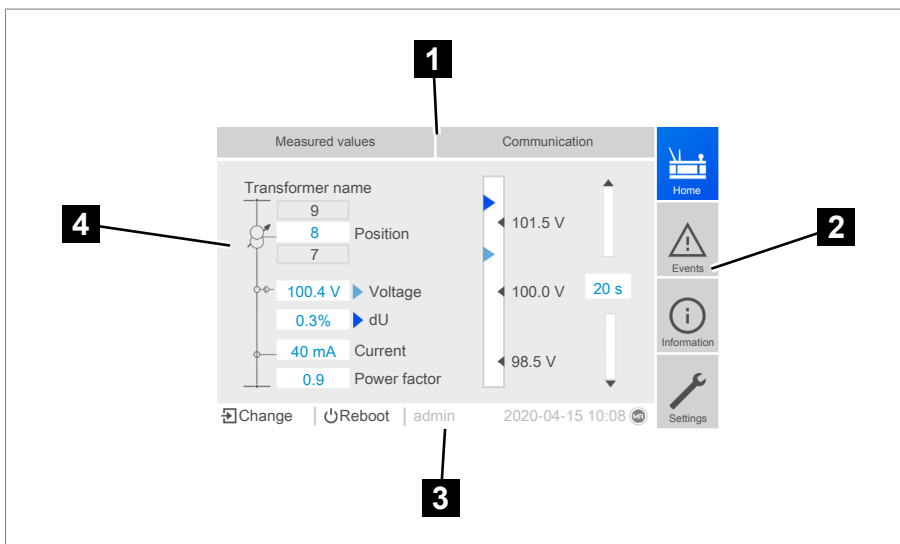

Figure 9: Home

1 Secondary navigation or navigation path	2 Primary navigation
3 Status bar	4 Display area

Measured values/display

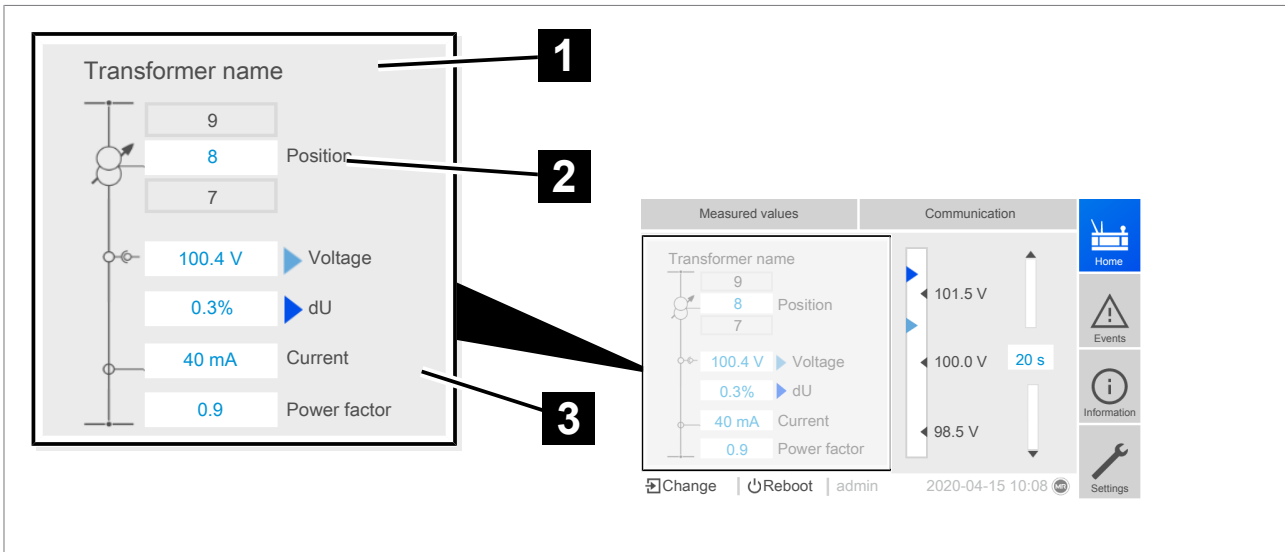

Figure 10: Measured values

- |   |                |
|---|----------------|
| 1 Transformer name (can be edited)  | 2 Tap position |
| 3 Actual measured values: Voltage, control deviation with correction, current, power factor |                |

Desired values/actual values/delay time

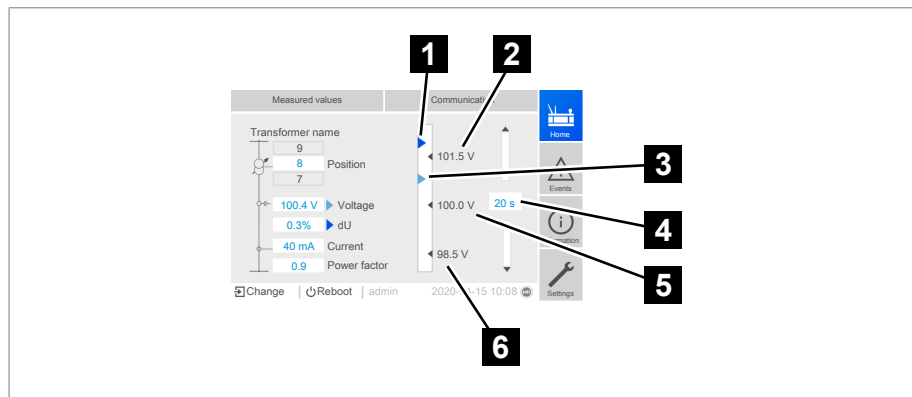

Figure 11: Display

- |   |                            |
|---|----------------------------|
| 1 Display of the corrected voltage (correction due to compensation or parallel operation) | 2 Upper limit of bandwidth |
| 3 Measured voltage  | 4 Delay time T1            |
| 5 Desired value   | 6 Lower limit of bandwidth |



### 4.5.7.2 Operating concept

You can operate the device using the controls on the front panel or using the web-based Intuitive Control Interface visualization on a PC. The scope of function and structure of both options is virtually identical.

#### User rights and user roles

The device is equipped with a rights system and a roles system. The display and access rights to device settings or events can therefore be controlled at the user level. You can configure the rights system and roles system to meet your requirements. You will find more information in the User administration [► Section 9.1.10, Page 81] section.



You can only modify the device settings or parameters if you have the necessary user rights.

#### Logging in, logging out and changing users

The control of access rights to device settings and parameters is user-based. Several users can log in at the same time via the visualization and access the device.







If you want to operate the device via the controls and visualization at the same time, you have to log in on the device and via the visualization.

1. Select the **LOGIN** or **CHANGE** button in the status line.
  2. Enter your user name and password and select the **OK** button.
- ⇒ The name of the logged-in user appears in the status line.

To log out as a user, proceed as follows:

- Press the **LOGOUT** button in the status line.

#### Navigation

If you are operating the device using the operating controls on the front panel, you can use the keys  and  to navigate through the entire menu. The menu currently selected has a blue border. To open the highlighted menu, you have to press the  key. Pressing the  key returns you to the previous menu level.

If you are operating the device using the web-based visualization, you can navigate by clicking on the appropriate buttons:

1. Go to **Settings**.
2. Go to **Parameters**.
3. Go to **System**.
4. Go to **Time synchronization**.





5. Select **Time**.

In these operating instructions, the path for navigating to a parameter is always shown in an abridged form: Go to **Settings > Parameters > System > Time synchronization**.



**Setting parameters**

There are various ways to configure the settings, depending on the parameter.

**Selecting from a list**

1. Use  to navigate to the list and press .
2. Use  or  to highlight the list entry and press .
3. Press the **Accept** button to save the modified parameter.

**Entering a value**

1. Use  or  to select the value field and press .
- ⇒ If operating via the front panel, the numerical keypad appears.

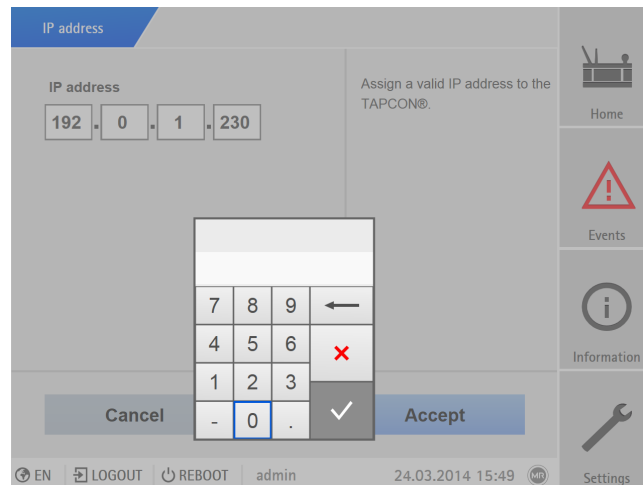



Figure 12: Entering a value

2. Enter the desired value and confirm with .
3. Press the **Accept** button to save the modified parameter.



**Entering text**

1. Use or to select the text box and press .  
 ⇨ If operating via the front panel, the keyboard appears.

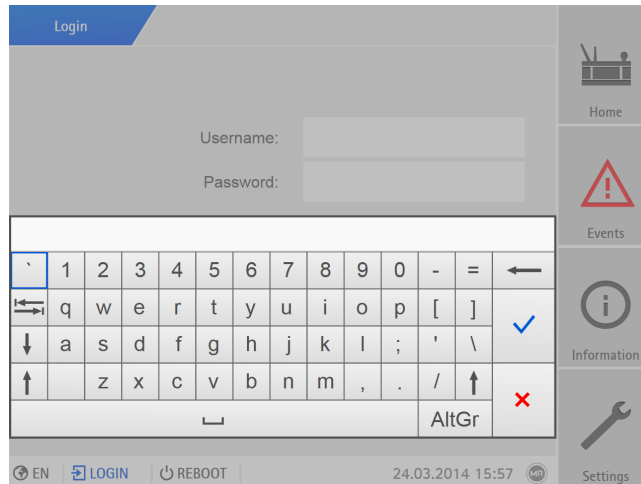

Figure 13: Entering text

2. Enter the desired text and confirm with .
3. Press the **Accept** button to save the modified parameter.

**Parameter search**

You can use the quick search function in the parameter menu to search for a parameter. Enter the name of the desired parameter in the **Search** entry field.

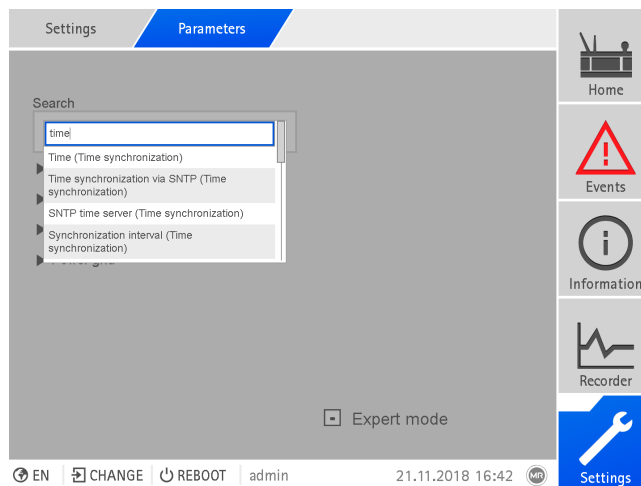

Figure 14: Quick search

### Expert mode

The device has an expert mode for entering the parameters. You can enter the parameters directly on the overview screen of the respective menu in this mode.

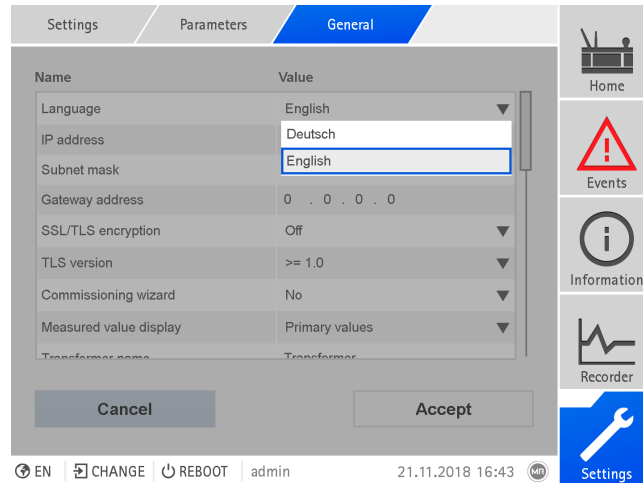

Figure 15: Expert mode

To activate the expert mode, proceed as follows:

1. Go to **Settings > Parameters**.
  2. Select the **Expert mode** checkbox.
- ⇒ Expert mode is active.

### Hiding/showing parameters

Depending on how you set the parameters, the device will hide or show additional parameters related to this function.

## 5 Packaging, transport and storage

### 5.1 Suitability, structure and production

The goods are packaged in a sturdy cardboard box. This ensures that the shipment is secure when in the intended transportation position and that none of its parts touch the loading surface of the means of transport or touch the ground after unloading.

The box is designed for a maximum load of 10 kg.

Inlays inside the box stabilize the goods, preventing impermissible changes of position, and protect them from vibration.

### 5.2 Markings

The packaging bears a signature with instructions for safe transport and correct storage. The following symbols apply to the shipment of non-hazardous goods. Adherence to these symbols is mandatory.

				
Protect against moisture	Top	Fragile	Attach lifting gear here	Center of mass

Table 8: Shipping pictograms

### 5.3 Transportation, receipt and handling of shipments

In addition to oscillation stress, jolts must also be expected during transportation. In order to prevent possible damage, avoid dropping, tipping, knocking over and colliding with the product.

If a crate tips over, falls from a certain height (e.g. when slings tear) or experiences an unbroken fall, damage must be expected regardless of the weight.

Every delivered shipment must be checked for the following by the recipient before acceptance (acknowledgment of receipt):

- Completeness based on the delivery slip
- External damage of any type

The checks must take place after unloading when the crate or transport container can be accessed from all sides.



**Visible damage** If external transport damage is detected on receipt of the shipment, proceed as follows:

- Immediately record the transport damage found in the shipping documents and have this countersigned by the carrier.
- In the event of severe damage, total loss or high damage costs, immediately notify the sales department at Maschinenfabrik Reinhausen and the relevant insurance company.
- After identifying damage, do not modify the condition of the shipment further and retain the packaging material until an inspection decision has been made by the transport company or the insurance company.
- Record the details of the damage immediately onsite together with the carrier involved. This is essential for any claim for damages!
- If possible, photograph damage to packaging and packaged goods. This also applies to signs of corrosion on the packaged goods due to moisture inside the packaging (rain, snow, condensation).
- Be absolutely sure to also check the sealed packaging.

**Hidden damage** When damages are not determined until unpacking after receipt of the shipment (hidden damage), proceed as follows:

- Make the party responsible for the damage liable as soon as possible by telephone and in writing, and prepare a damage report.
- Observe the time periods applicable to such actions in the respective country. Inquire about these in good time.

With hidden damage, it is very hard to make the transportation company (or other responsible party) liable. Any insurance claims for such damages can only be successful if relevant provisions are expressly included in the insurance terms and conditions.

### 5.4 Storage of shipments

When selecting and setting up the storage location, ensure the following:

- Protect stored goods against moisture (flooding, water from melting snow and ice), dirt, pests such as rats, mice, termites and so on, and against unauthorized access.
- Store the crates on timber beams and planks as a protection against rising damp and for better ventilation.
- Ensure sufficient carrying capacity of the ground.
- Keep entrance paths free.
- Check stored goods at regular intervals. Also take appropriate action after storms, heavy rain or snow and so on.

## 6 Mounting

### ⚠ DANGER



#### Electric shock!

Risk of fatal injury due to electrical voltage. Always observe the following safety regulations when working in or on electrical equipment.

- ▶ Disconnect the equipment.
- ▶ Lock the equipment to prevent an unintentional restart.
- ▶ Make sure all poles are de-energized.
- ▶ Ground and short-circuit.
- ▶ Cover or cordon off adjacent energized parts.

### ⚠ WARNING



#### Electric shock!

Dangerous high voltages may occur when a current transformer is operated with an open secondary circuit. This can lead to death, injuries and property damage.

- ▶ Never operate a current transformer with an open secondary circuit; short-circuit the current transformer to prevent this.
- ▶ Observe the information in the current transformer operating instructions.

### NOTICE

#### Damage to the device!

Electrostatic discharge may cause damage to the device.

- ▶ Take precautionary measures to prevent the build-up of electrostatic charges on work surfaces and personnel.

### 6.1 Preparation

The following tools are needed for mounting:



Depending on the installation site and mounting version, you may need additional tools and corresponding attachment material, such as screws, nuts and washers which are not included in the scope of delivery.

- Depending on mounting version:
  - Electric jigsaw for flush panel mounting.
  - Drill for wall mounting (wall mounting with housing).
- Screwdriver for connecting the signal lines and supply lines.

## 6.2 Minimum distances

### NOTICE

#### Damage to the device!

Insufficient circulation of ambient air can result in damage to the device due to overheating.

- ▶ Keep the ventilation slots clear.
- ▶ Ensure sufficient distance to neighboring components.
- ▶ Only mount device in horizontal position (ventilation slots are at the top and bottom).

To the base of the control cabinet	Minimum clearance: 88.9 mm (3.5 in)
To the roof of the control cabinet	Equivalent to 2RU
Between the device and other assemblies on offset cap rails	

Table 9: Minimum clearances in the control cabinet

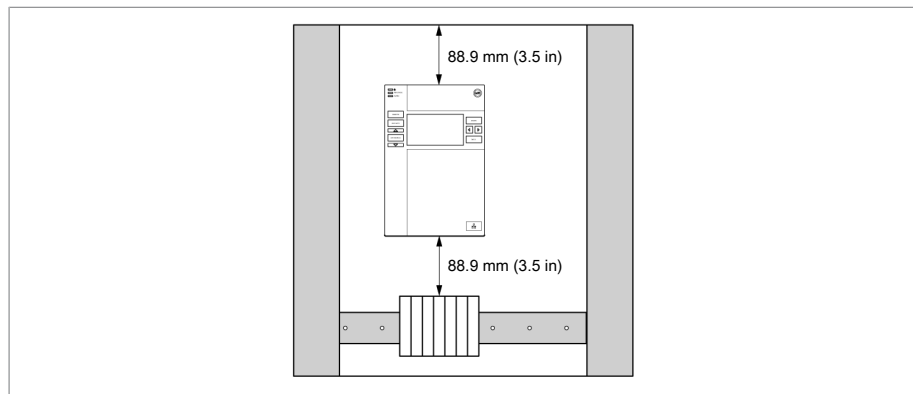

Figure 16: Minimum clearances

For other installation types, contact Maschinenfabrik Reinhausen GmbH.

## 6.3 Assembly variants

### 6.3.1 Flush panel mounting

The device can be mounted in a control panel using tension clamps. The recommended wall thickness is 2...5 mm.

**Dimensions for the control panel cutout**

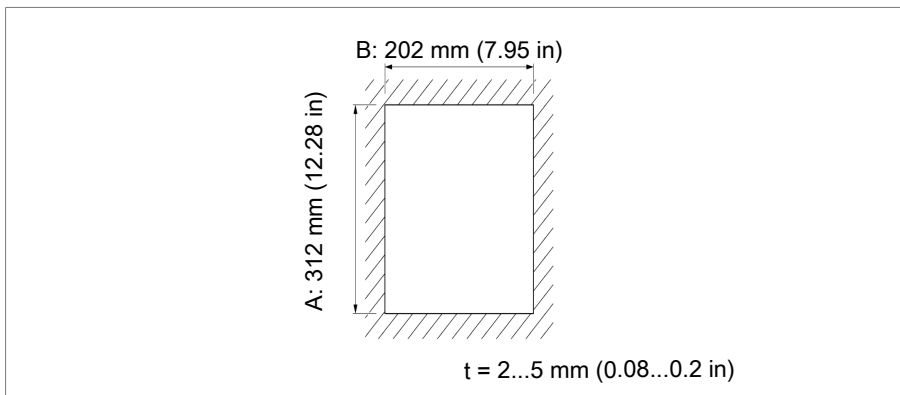

Figure 17: Dimensions for the cutout

1. Cut out the section for the control panel.

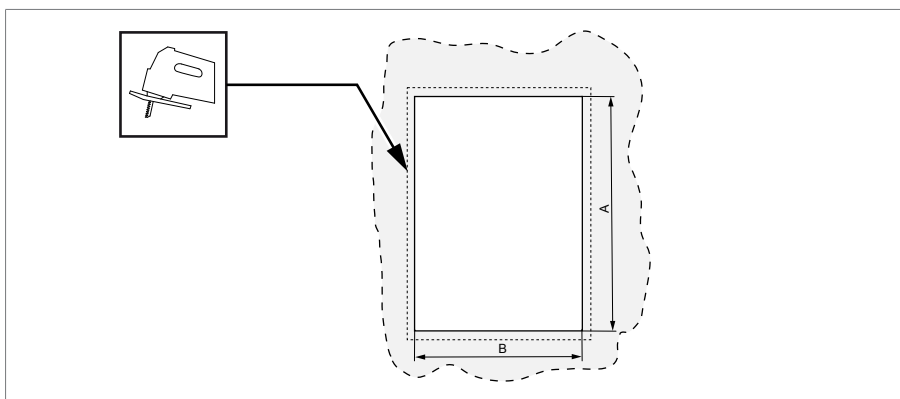

Figure 18: Cutting out the section for the control panel

2. Slide the device into the cutout from the front and insert tension clamps.

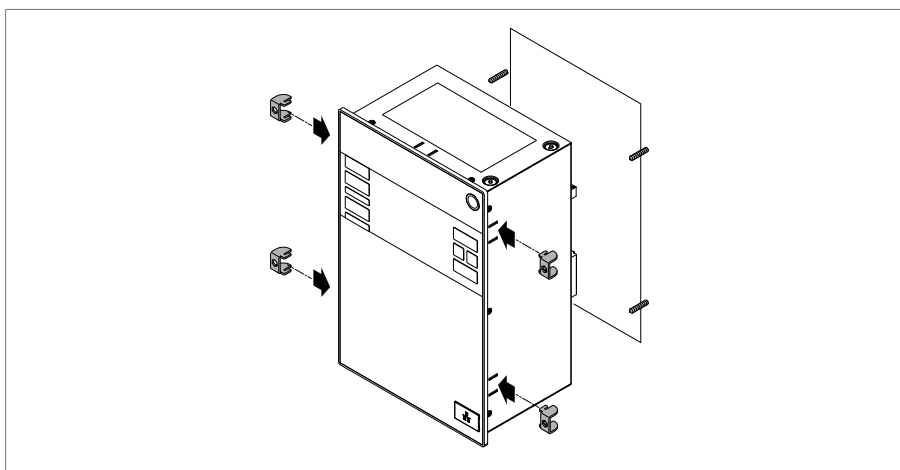

Figure 19: Inserting the device into the cutout

3. Secure the device using the tension clamps.

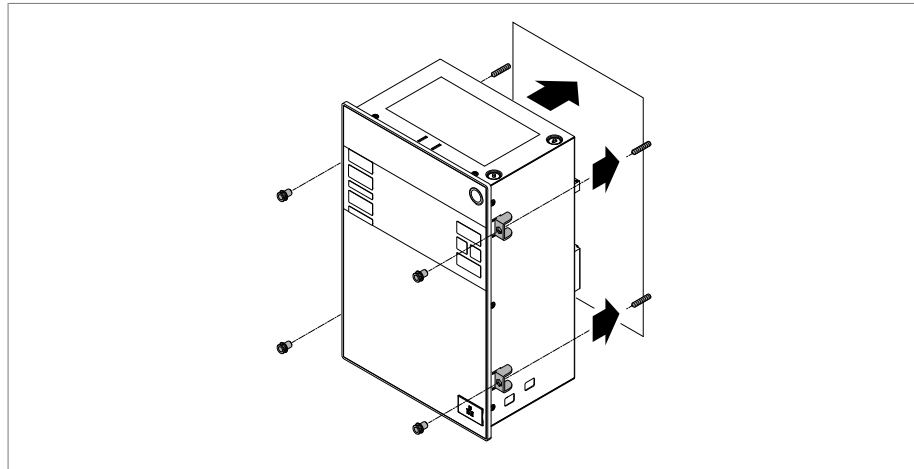

Figure 20: Securing device

⇒ The device is mounted and can be wired up.

### 6.3.2 Wall mounting with housing (optional)

For wall mounting, the device is fixed to the wall in a housing. The housing is an optional accessory.

Drill 4 holes, each 5.5 mm in diameter, in the wall as shown in the drilling template below.

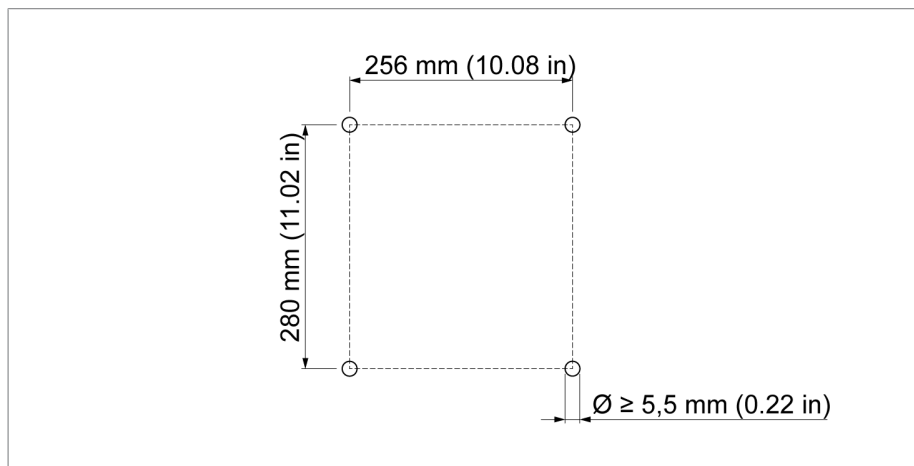

Figure 21: Drilling template for wall mounting

✓ Close the device door.



The screws for wall mounting are not included in the scope of supply. The screw length required depends on the wall thickness.

► Fix the device on the wall from behind using 4 screws (M5) **2**.

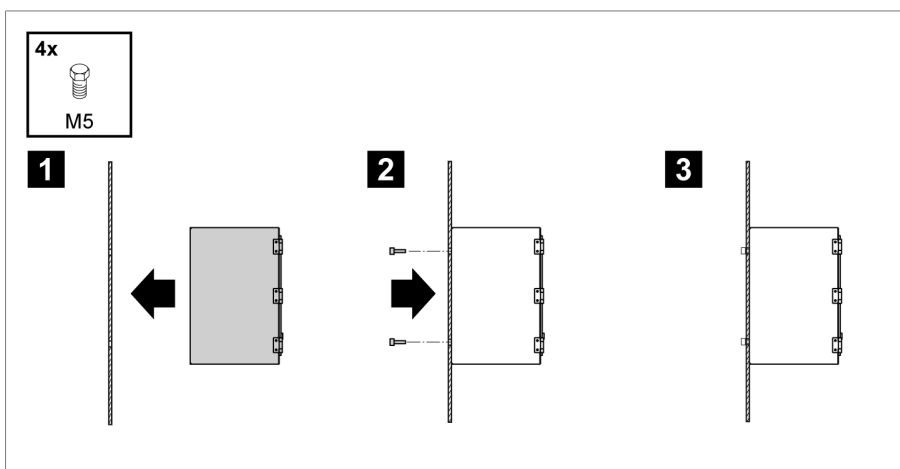

Figure 22: Wall mounting

⇒ The device is mounted and can be wired up **3**.

Proceed with wiring as shown in the connection diagram and as described in the Connecting device section.

## 6.4 Connecting device

### ▲ WARNING



#### Electric shock!

Connection errors can lead to death, injury or property damage.

- ▶ Ground the device with a protective conductor using the grounding screw on the housing.
- ▶ Note the phase difference of the secondary terminals for the current transformer and voltage transformer.
- ▶ Connect the output relays correctly to the motor-drive unit.



Supply the voltage via separators and ensure that current paths can be short-circuited. Fit the separator, clearly labeled and freely accessible, close to the device's power supply. This ensures that the device can be replaced with ease in the event of a defect.

#### Wiring information

- To obtain a better overview when connecting cables, only use as many cables as necessary.
  - Observe the connection diagram [▶ Section 13.14, Page 149].
  - Only use the specified cables for wiring. Note the cable recommendation [▶ Section 6.4.1, Page 40].
  - Wire the leads to the system periphery.
  - For wall mounting with housing (optional):
    - When wiring the device, use the cable glands below the housing if necessary.
    - **NOTICE!** Damage to the device! If any cable glands remain open, the IP degree of protection cannot be assured. Close off unused cable glands using dummy plugs.
1. Disconnect the connectors required.
  2. Strip insulation from cables and wires.
  3. Crimp stranded wires with wire end sleeves.
  4. Guide leads into corresponding connector terminals.
  5. Fasten screws for the corresponding terminals using a screwdriver.
  6. Plug connectors into the correct slots.

### 6.4.1 Cable recommendation

Please note the following Maschinenfabrik Reinhausen recommendation when wiring the device.



Excessive line capacitance can prevent the relay contacts from interrupting the contact current. In control circuits operated with alternating current, take into account the effect of the line capacitance of long control cables on the function of the relay contacts.

If you want to route Ethernet connections from a control cabinet or building, we recommend using fiber-optic cables (in accordance with the IEC 61850-90-4 recommendation).

Cable	Interface	Cable type	Conductor cross-section	Max. length
Power supply (external)	X9	Unshielded	1.5 mm <sup>2</sup>	
Voltage measurement	UI-X7	Shielded		
Current measurement	UI-X7	Unshielded	2.5 mm <sup>2</sup>	
Digital signal inputs	DI 16	Shielded	4 mm <sup>2</sup>	400 m (<25 Ω/km)
Digital signal outputs	DO 8	Shielded	1.5 mm <sup>2</sup>	
Analog signal inputs	AI 4	Shielded	1 mm <sup>2</sup>	400 m (<25 Ω/km)
RS232, D-SUB 9-pole	COM X3	Shielded	0.25 mm <sup>2</sup>	25 m
RS485	COM-X6	Shielded	0.25 mm <sup>2</sup>	140 m
CAN bus	COM-X6	Shielded	0.75 mm <sup>2</sup>	2000 m (total CAN bus)
Ethernet RJ45	X2, X3	Min. CAT5, shielded S/FTP		100 m
Ethernet FO	COM X4	Duplex LC multi-mode, Om3, 1310 nm		2000 m
110 V DC output	X8	Unshielded	1.5 mm <sup>2</sup>	
RJ45 patch cables		Min. CAT5, shielded S/FTP		approx. 30 cm

Table 10: Recommendation for connection cables

\*) Observe line capacitance, see note above.

## 6.4.2 Electromagnetic compatibility

The device has been developed in accordance with applicable EMC standards. The following points must be noted in order to maintain the EMC standards.

### 6.4.2.1 Wiring requirement of installation site

Note the following when selecting the installation site:

- The system's overvoltage protection must be effective.
- The system's ground connection must comply with all technical regulations.

- Separate system parts must be joined by a potential equalization.
- The device and its wiring must be at least 10 m away from circuit-breakers, load disconnectors and busbars.

### 6.4.2.2 Wiring requirement of operating site

Note the following when wiring the operating site:

- Route the connecting leads in grounded metal cable ducts.
- Do not route lines which cause interference (e.g. power lines) and lines susceptible to interference (e.g. signal lines) in the same cable duct.
- Maintain a distance of more than 100 mm between lines which cause interference and those which are susceptible to interference.

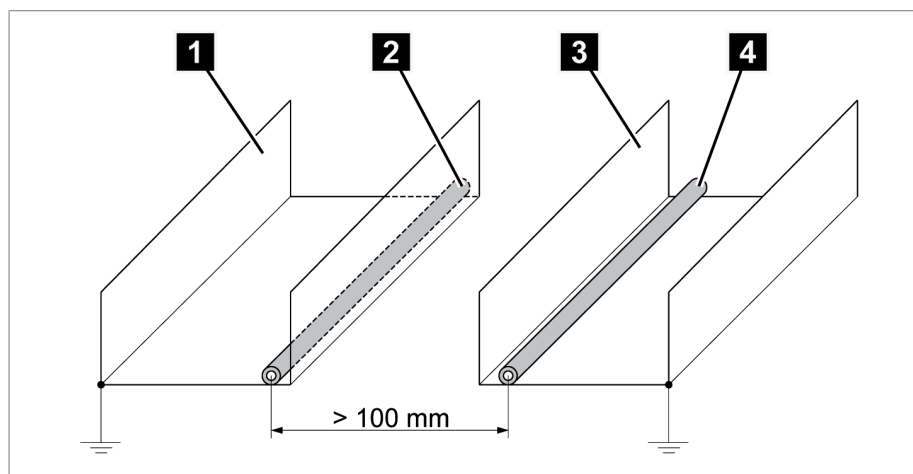

Figure 23: Recommended wiring

1 Cable duct for lines causing interference	3 Cable duct for lines susceptible to interference
2 Line causing interference (e.g. power line)	4 Line susceptible to interference (e.g. signal line)

- Short-circuit and ground reserve lines.
- Never connect the device with a multi-wire collective pipe.
- For signal transmission, use shielded lines with individual conductors (outgoing conductor / return conductor) twisted in pairs.
- Connect full surface of shielding (360°) to device or to a nearby grounding bar.



Using single conductors may limit the effectiveness of the shielding. Connect close-fitting shielding to cover all areas.

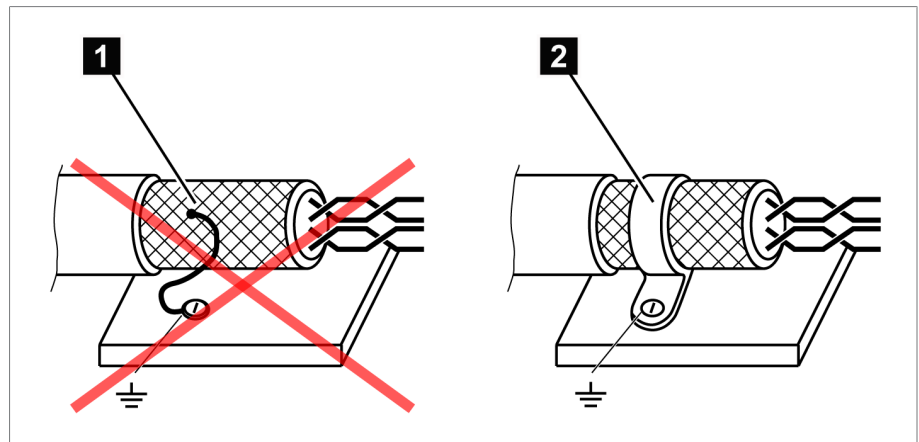

Figure 24: Recommended connection of the shielding

1 Connection of the shielding via a single conductor

2 Full-surface connection of the shielding

#### 6.4.2.3 Wiring requirement in control cabinet

Note the following when wiring in the control cabinet:

- The control cabinet where the device will be installed must be prepared in accordance with EMC requirements:
  - Functional division of the control cabinet (physical separation)
  - Constant potential equalization (all metal parts are joined)
  - Line routing in accordance with EMC requirements (separation of lines which cause interference and those susceptible to interference)
  - Optimum shielding (metal housing)
  - Overvoltage protection (lightning protection)
  - Collective grounding (main grounding rail)
  - Cable bushings in accordance with EMC requirements
  - Any contactor coils present must be interconnected
- The device's connection cables must be laid in close contact with the grounded metal housing or in metallic cable ducts with a ground connection.
- Signal lines and power lines/switching lines must be laid in separate cable ducts.
- The device must be grounded on the provided screw, the protective ground connection, with a ground strap (cross-section of min. 8 mm<sup>2</sup> (0.32 in<sup>2</sup>)).

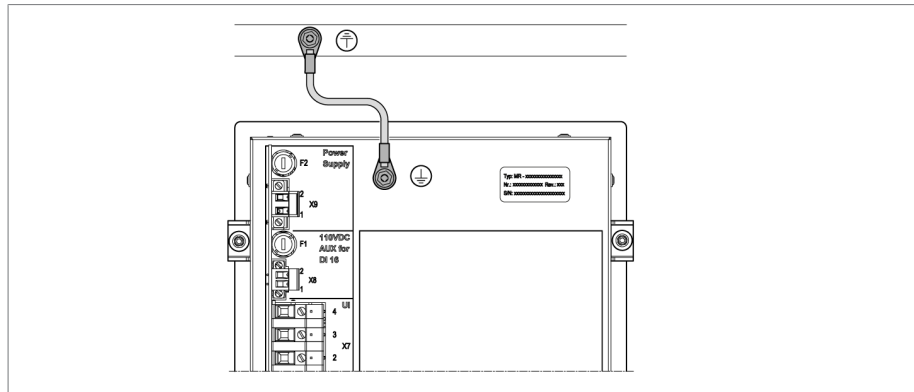

Figure 25: Ground strap connection

### 6.4.3 Connecting cables to the system periphery



To obtain a better overview when connecting cables, only use as many leads as necessary.

To connect cables to the system periphery, proceed as follows:

- ✓ Only use the specified cables for wiring. Note the cable recommendation [► Section 6.4.1, Page 40].
- Connect the lines to be wired to the device to the system periphery as shown in the connection diagrams supplied.

### 6.4.4 Connecting the CAN bus

#### 6.4.4.1 Shielding the CAN bus

In order for the CAN bus to operate faultlessly, you have to connect the shielding using one of the following variants. If you are not able to use any of the variants detailed below, we recommend using fiber-optic cables. Fiber-optic cables decouple the devices and are not sensitive to electromagnetic interference (surge and burst).

#### NOTICE

#### Damage to the device!

If you connect the CAN bus cable to devices with different potentials, current may flow across the shielding. This current may damage the device.

- Connect the devices to a potential equalization rail to equalize the potential.
- If both devices have different potentials, only connect the CAN bus cable shielding to one device.

**Variant 1: The connected devices share the same potential**

1. Connect all devices to a potential equalization rail to equalize the potential.
2. Connect the CAN bus cable shielding to all connected devices.

**Variant 2: The connected devices have different potential levels**

Note that the shielding is less effective with this variant.

- ✓ Connect the CAN bus cable shielding to **just one** device.
- ✓ Connect the wires of the shielded CAN bus cable in pins 10 (CAN H), 9 (CAN GND) and 8 (CAN L) of the COM-X6 connector.

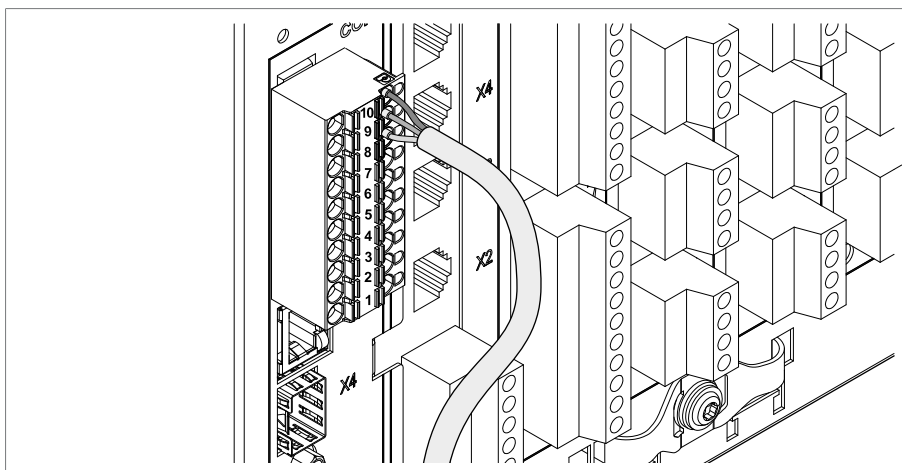

Figure 26: Connecting wires in pins 10, 9, 8

- ▶ Position the cable shielding; screw into place using the shield clamp provided and provide strain relief (using a cable tie).

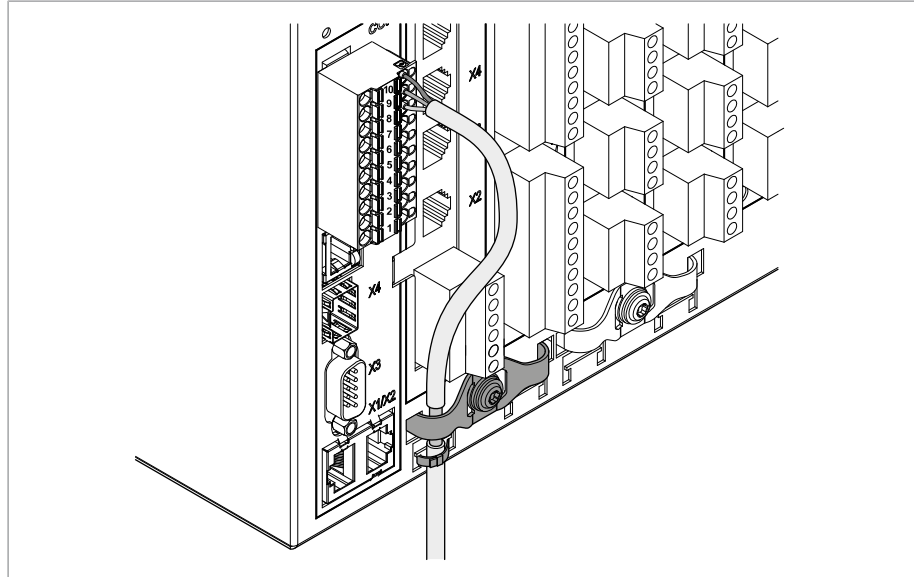

Figure 27: Shield clamp and strain relief

#### 6.4.4.2 Mounting terminating resistor of CAN bus

If you want to operate the device in parallel operation, you need to mount a 120  $\Omega$  terminating resistor at both ends of the CAN bus.

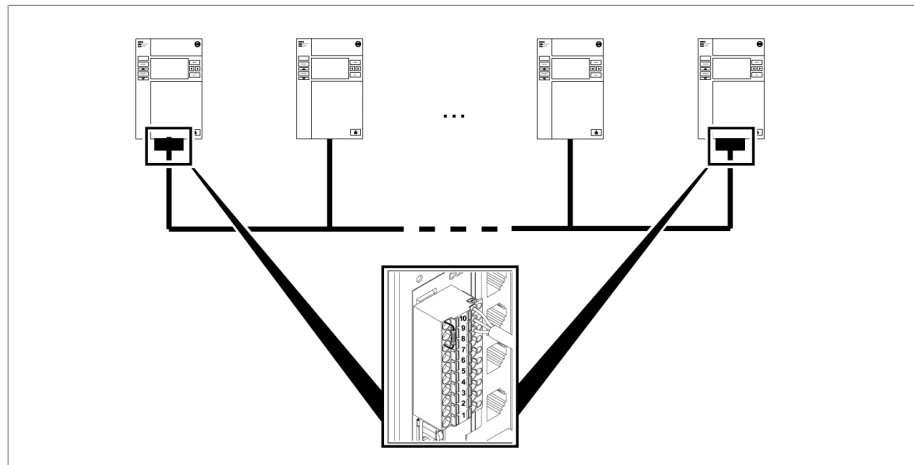

Figure 28: Terminating resistor of the CAN bus

- ▶ Mount terminal resistors in pins 10, 9 and 8 of the COM-X6 connector.

### 6.4.5 Connecting SCADA

#### NOTICE

#### Damage to the device!

Using the wrong data cable may damage the device.

► Only use data cables which comply with the description below.

Depending on the control system used, you have to connect the device with one of the following versions.

#### 6.4.5.1 Serial interface RS485 (COM-X6)

If you want to use the RS485 serial interface, you need to mount a 120  $\Omega$  terminating resistor at both ends of the RS485 bus.

1. Connect the wires of the shielded cable in pins 7 (Data +), 6 (GND) and 5 (Data-) of the COM-X6 connector.

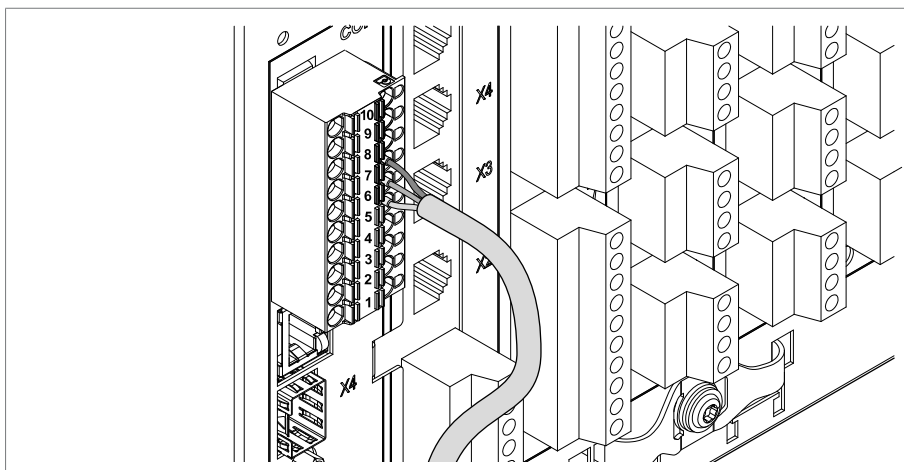

Figure 29: Connecting wires in pins 7, 6, 5

2. Position the cable shielding, screw it into the shield clamp provided, and provide strain relief (using a cable tie).

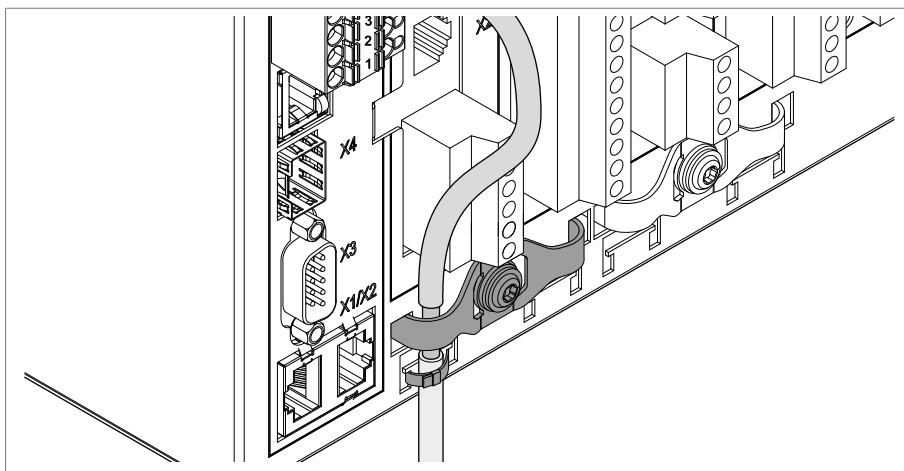

Figure 30: Shield clamp and strain relief

3. Connect the COM-X1 RJ45 interface and the CPU-X4 interface together using the patch cable.

#### 6.4.5.2 Serial RS232 (D-SUB 9-pole) interface

##### Data cable

To connect the device via the RS232 interface, use a data cable with the following structure:

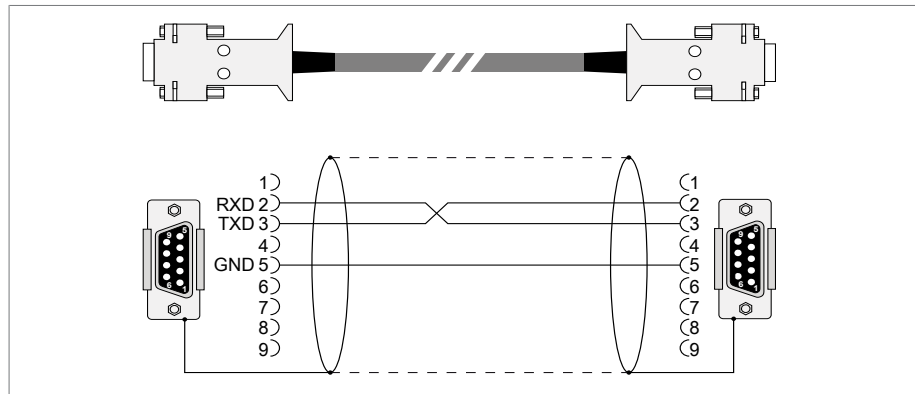

Figure 31: RS232 data cable (9-pole)

##### D-SUB 9-pole plug connection

Only use 9-pole D-SUB plugs with the following characteristics:

- Plug housing is metallic or metal-plated
- Cable shielding is connected with the plug using one of the following two variants:
  - Shielding is screwed down with traction relief.
  - Shielding is soldered to the plug housing.

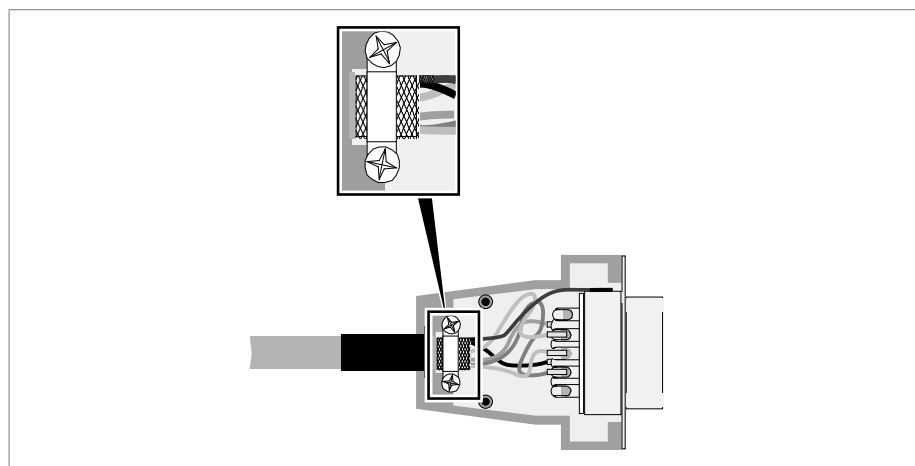

Figure 32: Example of a soldered shielding on a plug housing

### Connection

1. Connect the D-SUB 9-pole connector to the COM-X3 interface.
2. Connect the COM-X1 RJ45 interface to the CPU-X5 interface using the supplied patch cable.

#### 6.4.5.3 Fiber-optic cable

To ensure error-free data transmission, observe the information from the manufacturer of the fiber-optic cable and the following instructions:

- Radii must not fall below the minimum permissible bend radii (do not bend fiber-optic cable).
- The fiber-optic cables must not be over-stretched or crushed. Observe the permissible load values.
- The fiber-optic cables must not be twisted.
- Be aware of sharp edges because they can damage the fiber-optic cable's coating during laying or can place mechanical loads on the coating later on.
- Provide a sufficient cable reserve near distributor cabinets. Lay the reserve such that the fiber-optic cable is neither bent nor twisted when tightened.

#### Fiber-optic cable, 1,310 nm Multimode

1. Slide the SFP module into the COM-X4 interface **1** and fold down the clasp **2**.

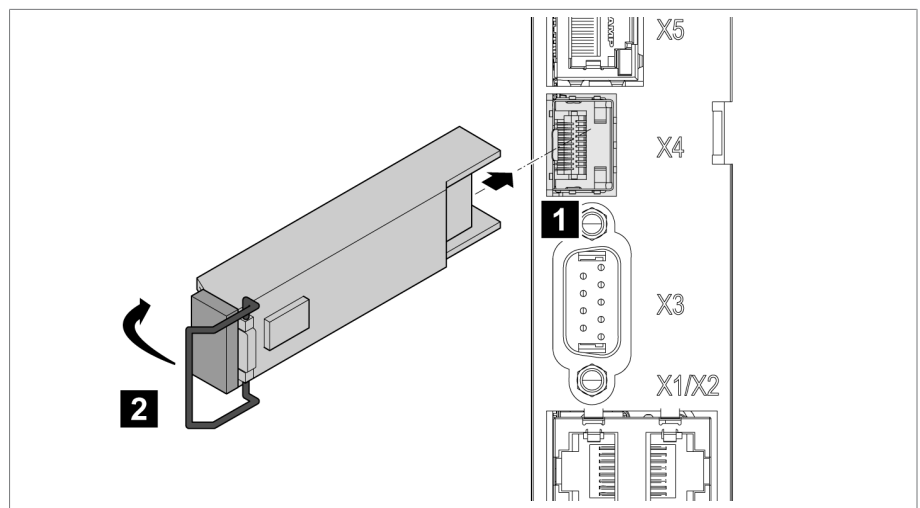

Figure 33: Engaging the SFP module

2. Remove the SFP module dust plug.

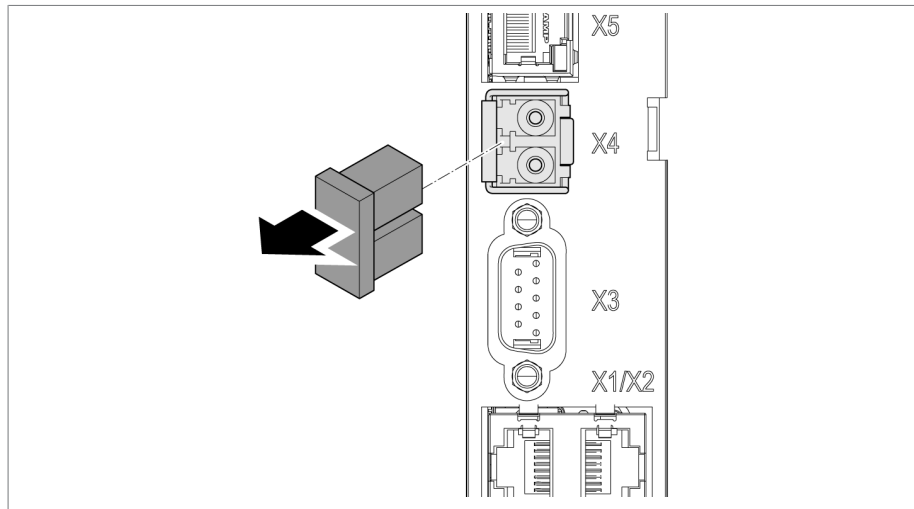

Figure 34: Remove the dust protection

3. Insert the fiber-optic cable with LC duplex into the SFP module COM-X4 interface.

4. Connect the COM-X5 to the CPU-X2 using the supplied patch cable.

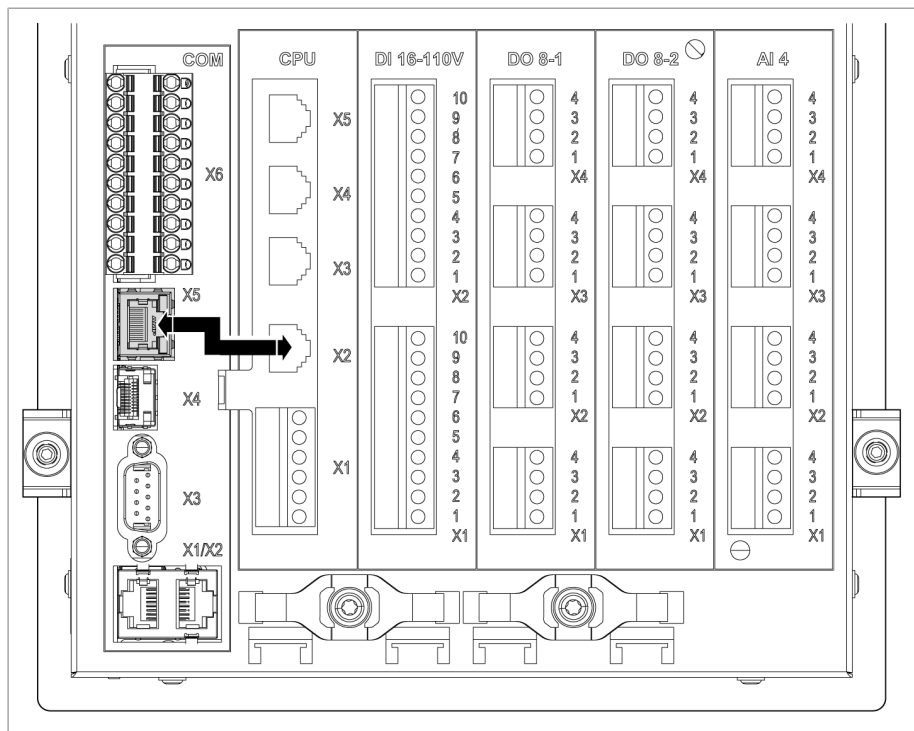

Figure 35: Connecting CPU-X5 and COM-X2

### Serial fiber-optic cable

You will need the CM-0847 FO converter if you want to connect your control system via the serial fiber-optic cable.

- ▶ Connect the serial fiber-optic cable and the converter to the CPU-X5 interface.

#### 6.4.5.4 Ethernet interface

- ▶ Connect the Ethernet cable (RJ45 connector) to the COM-X3 interface.

### 6.4.6 Wiring voltage measurement/current measurement UI

You must fuse the voltage measurement circuit in accordance with the conductor cross section used. You can use the following fuse types:

	Miniature circuit breaker	Safety fuse
Standard	IEC 60947-2	IEC 60269
Rated voltage	400 V (L-L) or 230 V (L-N)	
Rated current	30 mA...16 A	
Characteristics	B, C, K or Z	Fast-acting, medium-acting or delayed-acting
Rated switching capacity	50 kA	

For installation in accordance with  
IEC 61010-2-30 CAT II: 10 kA

Table 11: Permissible fuse types

1. Voltage measurement: Feed the wires into the terminals UI:X7-4 (N conductor) and UI:X7-3 (L conductor) and fasten them using a screwdriver.

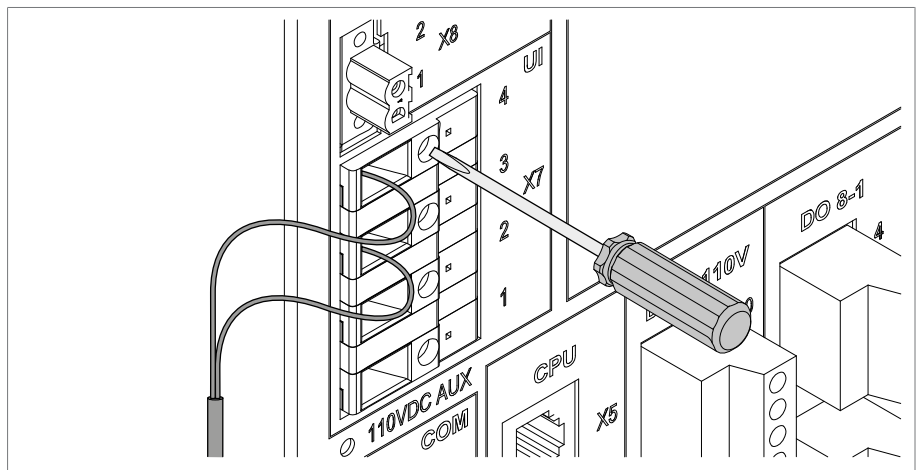

Figure 36: UI:X7-4/3

2. Current measurement: Feed the wires into the terminals UI:X7-2 (l) and UI:X7-1 (k) and fasten them using a screwdriver.

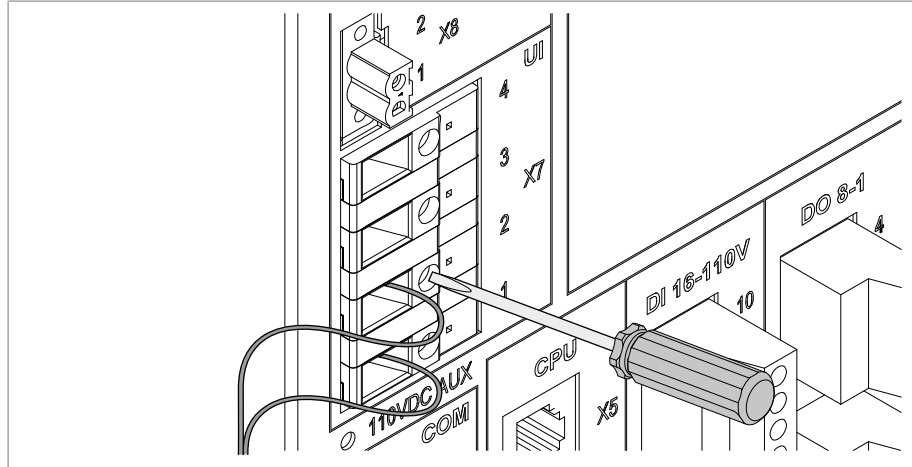

Figure 37: UI:X7-2/1

#### 6.4.7 Wiring analog inputs AI

##### NOTICE

##### Damage to the device and sensors!

Incorrectly connected and configured analog inputs/outputs may result in damage to the device and sensor.

- ▶ Follow information about connecting analog sensors.
- ▶ Configure analog inputs and outputs according to the connected sensors.

You can connect the following types of analog sensors:

- 0/4...20 mA
- 0 to 10 V
- PT100/PT1000 (2-wire, 3-wire, 4-wire) indirectly via measuring transducer

In order to correctly record the analog signals, you must place the cable shielding on the grounding bar. The cable shielding should only be removed just prior to connecting to ensure that the section with unshielded cables is kept as short as possible. The shielding must be connected with shielding clips.

### Block diagram and wiring versions

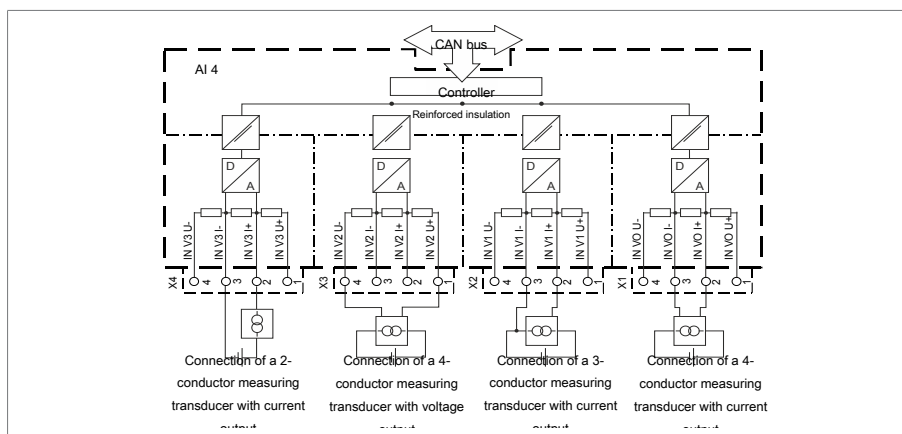

Figure 38: Block diagram for analog inputs

1. Lead the wires into the connector and fasten them using a screwdriver.
2. Insert the plug into the respective slot in accordance with the connection diagram [► Section 13.14, Page 149] and screw into place.

#### 6.4.8 Wiring digital inputs DI

If you use digital inputs, these have to be supplied with an auxiliary voltage of 110 V DC.

1. Feed the wires into the terminal of the DI 16-110V plug in accordance with the connection diagram [► Section 13.14, Page 149] and fasten them using a screwdriver.
2. Plug the connector into the respective slot and screw it into place.

#### Auxiliary power supply for digital inputs

1. Feed the wires into the terminals X8:2 and X8:1 of the X8 plug in accordance with the connection diagram [► Section 13.14, Page 149] and fasten them using a screwdriver.
2. Plug the connector into the respective slot and screw it into place.

### 6.4.9 Wiring digital outputs DO

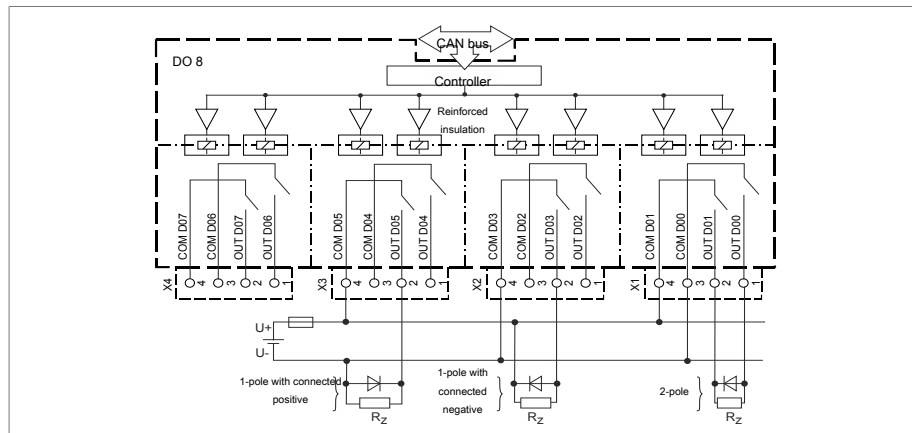

Figure 39: Block diagram for digital outputs

1. Feed the wires into the terminal of the plug connection diagram and fasten them using a screwdriver.
2. Plug the connector into the respective slot and screw it into place.

### 6.4.10 Wiring resistor contact series

Connect the resistor contact series to the COM X6 and AI 4 interfaces in accordance with the connection diagram [► Section 13.14, Page 149].

### 6.4.11 Connecting the power supply

You may only connect the device to circuits with an external overcurrent protective device and an all-pole isolating device, allowing the equipment to be fully de-energized if required (service, maintenance etc.).

Suitable equipment includes isolating devices in accordance with IEC 60947-1 and IEC 60947-3 (e.g. circuit breakers). Observe the properties of the relevant circuits (voltage, maximum currents) when selecting the circuit breaker type. In addition, observe the following:

- It must be easy for the operator to access the isolating device
- The isolating device must be labeled for the device and the circuits to be isolated
- The isolating device may not be a part of the power line
- The isolating device may not interrupt the main protective conductor

**Miniature circuit breaker** You must fuse the power supply circuit with a miniature circuit breaker. The miniature circuit breaker must have the following properties:

- Rated current: 6...10 A
- Triggering characteristic: C, K or Z

**Conductor cross-section** For the power supply circuit, use a conductor cross-section suitable for the miniature circuit breaker that you have selected, but at least 1.5 mm<sup>2</sup> (AWG 15).



### Connecting the power supply

- ▶ Connect the power supply in accordance with the connection diagram [▶ Section 13.14, Page 149].



## 6.5 Performing tests

### NOTICE

#### Damage to device and system periphery!

An incorrectly connected device can cause damage to the device and system periphery.

- ▶ Check the entire configuration before commissioning.
- ▶ Prior to commissioning, check the supply voltage and the measured voltage.
  
- ▶ Connecting the device to mains.
  - ⇒ The display shows the MR logo and then the operating screen.
  - ⇒ The *voltage display* LED on the top left of the device's front panel lights up.



## 7 Initial steps

**NOTICE**

**Damage to device and system periphery!**

An incorrectly connected device can cause damage to the device and system periphery.

- ▶ Check the entire configuration before commissioning.

As soon as the device has powered up and the start screen is displayed, you will be asked to make the following settings.

### 7.1 Establishing connection to visualization

A connection to the visualization can be established using two interfaces:

- Front interface (for local access)
- Optional: Interface X3 on the rear of the device (for access via remote display, control center etc.)

**System requirements**

To access the web-based visualization, you need a PC with an HTML5-capable browser. The display is optimized for the following browsers:

- Microsoft® Internet Explorer 11
- Google Chrome™

**Establishing a connection via front interface**

1. Remove the interface cover on the front of the device.
2. Connect the COM-X2 to the CPU-X3 using the supplied patch cable.

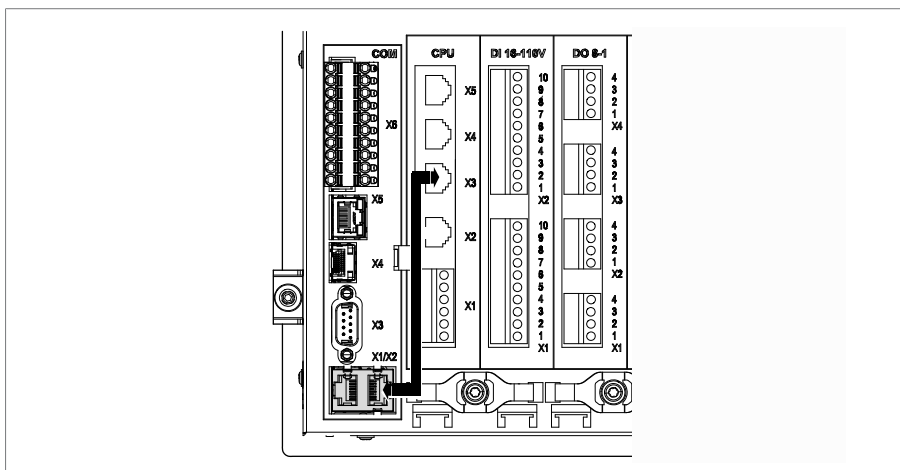

Figure 40: Patch cable on the rear

3. Connect the PC and the device via the front interface using an Ethernet cable (RJ45 plug).

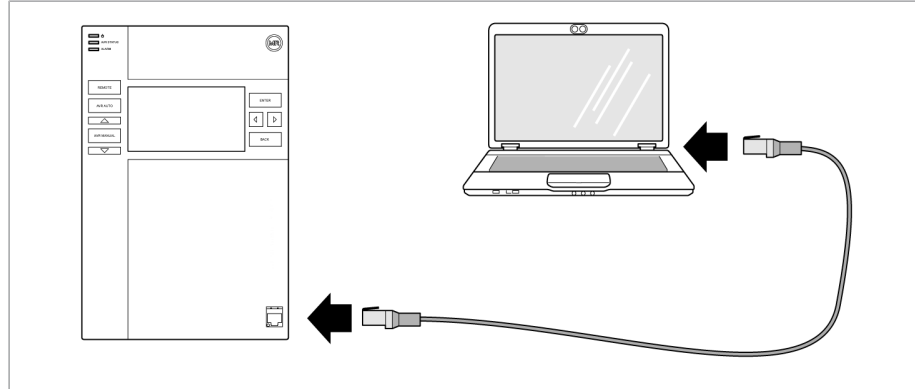

Figure 41: Establishing a connection via the front interface

4. Enter the visualization's IP address `http://192.168.165.1`, or if SSL encryption is active, enter `https://192.168.165.1` in the browser on the PC.

⇒ The visualization is accessed.

#### Establishing a connection via the rear CPU-X3 interface

1. Connect the PC and device via the rear CPU-X3 interface using the pre-assembled patch cable.
2. Go to **Communication** on the device to display the device's IP address.
3. Assign a unique IP address to the PC in the same subnet as the device (e.g. `192.0.1.100`).
4. Enter the visualization's IP address (e.g. `http://192.0.1.230`; if SSL encryption is active enter `https://192.0.1.230`) in the browser on the PC.

⇒ The visualization is accessed.

#### Setting the language

English	Italian
German	Portuguese
French	Russian
Spanish	Chinese
Korean	Polish

Table 12: Available display languages

1. Press the  EN button in the status bar.
2. Select the desired language from the list field.
3. Press the Accept button to adopt the parameter.
  - ⇒ The "Restart device" dialog is displayed.



4. Restart the device to apply the changed language setting.

### **Downloading the operating instructions**

Download the operating instructions from the device to start device parameterization.

▶ Select  in the status line.

⇒ The operating instructions will be downloaded.

The document is also available for download in the MR Customer Portal and on our website [www.reinhausen.com](http://www.reinhausen.com).

## 8 Commissioning

### NOTICE

#### Damage to device and system periphery!

An incorrectly connected device can cause damage to the device and system periphery.

- ▶ Check the entire configuration before commissioning.

### 8.1 Commissioning wizard

If you want the device to help when setting the relevant parameters, you can use the commissioning wizard. The commissioning wizard provides a selection of parameters that you can configure in order.

A detailed description of each of the parameters can be found in the Operation [▶ Section 9, Page 67] chapter.



To call up the commissioning wizard, you will need the necessary access rights [▶ Section 9.1.10, Page 81].



When in delivery status, you can log in as the administrator as follows:

- User name: `admin`
  - Password: `admin`
1. Log in as a user with the necessary access rights.
  2. Go to **Settings > Commissioning wizard**.
  3. Press the **Next** button to launch the commissioning wizard.
  4. Follow the on-screen instructions.

Once you have entered all of the parameters relevant to commissioning, continue with the function test [▶ Section 8.2, Page 60].

### 8.2 Function tests

Before switching from manual mode to auto mode, Maschinenfabrik Reinhausen recommends carrying out function tests. These function tests are described in the following sections. Note the following points for all function tests:

- You must ensure that REMOTE mode is disabled before you can control the on-load tap-changer manually in manual mode.
- You can only activate the on-load tap-changer manually in manual mode using the  and  keys.
- You have to be logged in to the device as a user with a parameter configurator or administrator user role.



When in delivery status, you can log in as the administrator as follows:

- User name: admin
- Password: admin

During the function test, you must set the most important parameters. Details on the parameters listed can be found in the Operation [► Section 9, Page 67] chapter.

### 8.2.1 Checking measured values and status of digital inputs and outputs

Upon commissioning the device, check whether the measured values and status of digital inputs and outputs are plausible. To do so, use an additional measuring device if necessary to check the individual measured values.

1. Go to **Information > Hardware**.
2. Select the individual **assemblies** one after another and check the individual measured values or the status of digital inputs and outputs.
3. If errors arise, check the measurement path and the wiring [► Section 6.4, Page 40].

### 8.2.2 Testing the device control function

✓ Supply voltage must be present.

1. Press **AVR MANUAL** to select manual mode.
2. Set the transmission ratio for the voltage transformer, current transformer and transformer circuit.
3. Measure actual voltage and compare with the measured value displayed on the device's main screen.
4. Select the **Measured values** menu item to display the operating values for current and power and compare them with the values of the operation measurement instruments.
5. Control the on-load tap-changer manually using the **▲** or **▼** keys until the measured voltage  $U_{\text{actual}}$  reaches the desired voltage  $U_{\text{desired}}$  ("desired value 1").
6. Set the desired value to the value you want.
7. Set the bandwidth depending on the step voltage [► Page 107].
8. Set the delay time T1 to 20 seconds [► Page 108].
9. Set the time response T1 to linear [► Page 108].
10. Press **▲** to raise the on-load tap-changer one step.
11. Press **AVR AUTO** to select auto mode.
  - ⇒ If the actual voltage is outside the bandwidth, the device returns the on-load tap-changer to the original operating position after 20 seconds.
12. Press **AVR MANUAL** to select manual mode.
13. Press **▼** to lower the on-load tap-changer one step.

14. Press **AVR AUTO** to select auto mode.
  - ⇒ If the actual voltage is outside the bandwidth, the device returns the on-load tap-changer to the original operating position after 20 seconds.
15. Press **AVR MANUAL** to select manual mode.
16. Set the delay time T1 [► Page 108] to the desired value.



We recommend a temporary setting of 100 seconds for **delay time T1** when commissioning the transformer. Depending on the operating conditions, you can also specify the delay time following a longer observation period. In this regard, it is useful to register how the actual voltage progresses and the number of tap-change operations per day.

### 8.2.3 Checking parallel operation

To ensure that parallel operation functions correctly, the device must be commissioned in independent mode. Make sure that the conditions below have been met.

- All devices are set to the same operating parameters for "desired value" and "delay time T1" [► Page 108]
- The "Activate parallel operation" parameter is set to **ON**
- The desired Parallel operation method is selected.
- A different CAN bus address ( $\neq 0$ ) is set for all devices.
- All devices are in the same parallel operation group:
  - With parallel operation detection via group input: A signal is present at the same group input on all devices.
  - With parallel operation detection via topology: The circuit breakers are configured and connected so that the devices participate in parallel operation.

#### 8.2.3.1 Testing circulating reactive current minimization

Note that the following prerequisites must be met for the "circulating reactive current minimization" parallel operation method:

- You must use current transformers with the same connection values for all transformers in parallel operation.
- If you wish to operate in parallel operation with existing devices, you have to activate the Retrofit TAPCON® 2xx parameter.

Consult the section Circulating reactive current minimization for more information.

To set the circulating reactive current sensitivity, proceed as follows:

1. Select the "Circulating reactive current" parallel operation method.
2. Set circulating reactive current sensitivity to a value of 0%.
3. If necessary, activate the Retrofit TAPCON® 2xx function.



4. Adjust both transformers in independent mode to the same actual voltage using the on-load tap-changers.
5. Connect the transformers in parallel and enable parallel control.
  - ⇒ The status display in the **Parallel operation** menu lights up blue.
  - ⇒ Both devices must be within the bandwidth.
6. Set the desired value of both voltage regulators to the voltage currently measured.
7. On one of the two transformers, raise the tap position of the on-load tap-changer by one setting; on the second transformer, lower the tap position of the on-load tap-changer by one setting.
  - ⇒ Both devices remain within the bandwidth.
8. Increase the circulating reactive current sensitivity in small steps until the control deviation dU in the main screen is outside the bandwidth (depending on the device, greater than or less than the bandwidth).
9. Press **AVR AUTO** to select auto mode on all devices.
  - ⇒ All devices return the on-load tap-changers to the original tap positions.



If an on-load tap-changer does not switch back to its original tap position, you have to increase the circulating reactive current sensitivity.

If one of the on-load tap-changers switches one or more tap positions higher and the other switches the same amount lower, you need to reduce the circulating reactive current sensitivity.

After you have set the circulating reactive current sensitivity, continue with the function test for the circulating reactive current blocking limit described in the next section.

### 8.2.3.2 Testing the circulating reactive current blocking limit

This section describes how to run the function test for circulating reactive current blocking.

✓ Set the circulating reactive current blocking limit to a value of 20%.

1. Press **AVR MANUAL** on one voltage regulator to select manual mode.
2. Using manual control, adjust the relevant motor-drive unit upwards (for example 1...2 steps) by the maximum permitted tap difference in operating positions between the parallel operating transformers.



When setting the circulating reactive current blocking in the following process step, wait approximately 2 to 3 seconds between the individual steps.

3. In the **Parallel operation > Parallel operation method** menu item, set the **circulating reactive current** parallel operation method.

4. Reduce the circulating reactive current blocking limit parameter from the set value of 20% in steps of 1% until the message *Circulating reactive current blocking limit exceeded* is displayed.
  - ⇒ Any further regulation is blocked.
  - ⇒ After the set delay time for the parallel operation error message has elapsed, the circulating reactive current blocking message is displayed.
5. Increase the circulating reactive current blocking limit parameter again until the message *Circulating reactive current limit exceeded* disappears.
6. Press **AVR AUTO** to select auto mode.
  - ⇒ The motor-drive unit automatically returns to the original operating position.
7. Also set the value determined for the "circulating reactive current blocking limit" on the parallel operation voltage regulators.



If one or all voltage regulators display *Circulating reactive current blocking limit exceeded*, even though the control inputs are correctly connected for all voltage regulators, all voltage regulators will be blocked.

This could be due to various causes. Further information is given in the Troubleshooting [▶ Section 11, Page 131] section.

- ⇒ The function test for the circulating reactive current blocking limit is complete.

### 8.2.3.3 Checking tap synchronization method

#### NOTICE

#### Damage resulting from formation of a circulating reactive current!

If the parameters are not set correctly, damage may result from the formation of circulating reactive current and the resulting overload of transmission lines and transformers.

- ▶ Check the transformer nameplate.
- ▶ Set device parameters in accordance with the transformer configuration.



In parallel operation in accordance with the **Automatic tap synchronization** method, the tap positions of the transformers running in parallel are compared. It is therefore necessary that the transformers have the same position designation and that the *Raise* and *Lower* signals produce the same voltage change in all transformers.

Before starting the function test, you must carry out the following steps:

1. Assign the master function to one device.
2. Assign the follower function to the other devices.

3. Compare the tap position displays **3** of master **1** and follower **2**. All devices must display the same tap position. If this is not the case, switch all devices to the same tap position.

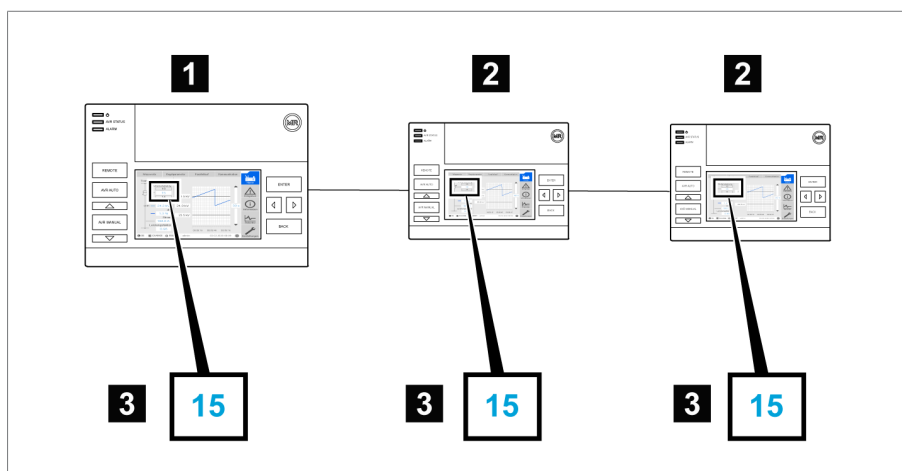



Figure 42: Comparing the tap position

1 Master	3 Tap position display
2 Follower	

4. Press **AVR MANUAL** on the follower to select manual mode.
5. If necessary, set the follower tapping direction.
6. Press **AVR MANUAL** on the master to select manual mode.
7. Press **▲** or **▼** on the master to manually change the tap position.
8. Press **AVR AUTO** on the follower to select auto mode.
  - ⇒ The follower switches to the same tap position as the master.
9. Press **AVR AUTO** on the master to select auto mode.
10. Press **AVR MANUAL** on the follower to select manual mode.
11. Press **▲** or **▼** on the follower to manually change the tap position.
  - ⇒ After expiration of the set delay time for parallel operation errors, there is a tap difference from the follower to the master.
12. Press **▲** several times on the follower to manually increase the tap position by the number of permitted steps ("Maximum permitted tap difference") and then one further step.
  - ⇒ After expiration of the set delay time for parallel operation errors, there is a tap difference to follower on the master.
  - ⇒ After expiration of the set delay time for parallel operation errors, there is a tap difference to master on the follower.
13. Press **AVR AUTO** on the follower to select auto mode.
  - ⇒ There is no response. All devices remain blocked.
14. Press **AVR MANUAL** on the master and follower to select manual mode.



15. Press  or  on the master and follower to manually set the desired step.

⇒ The function tests for the tap synchronization method are complete.

Installation and commissioning of the device is complete.



## 9 Operation

This chapter describes all the functions and setting options for the device.

### 9.1 System

#### 9.1.1 General

You can set general parameters in this menu item.

##### 9.1.1.1 Setting general device functions

You can set general device functions with the following parameters.

1. Go to **Settings > Parameters > System > General**.
2. Select the desired parameter.
3. Set the parameter.
4. Press the **Accept** button to save the modified parameter.

##### Commissioning wizard

You can use this parameter to set whether the commissioning wizard is to launch automatically when the device is restarted.

##### Measured value display

You can use this parameter to set whether the displayed measured values and control parameters are to refer to the primary side or secondary side of the measuring transducers.

##### Transformer name

You can use this parameter to enter a transformer name for identification purposes. The transformer name will be displayed on the main screen in the visualization.

##### Remote behavior

You can use this parameter to select the behavior of the device in REMOTE operating mode. You can set the remote behavior as follows.

- Using the visualization
- Setting using digital inputs

Select settings:

Setting	Description
Hardware only	The device accepts commands through digital inputs.
SCADA only	The device accepts commands via SCADA.
Hardware and SCADA	The device accepts commands via digital inputs and SCADA.

Table 13: Selecting remote behavior

### 9.1.1.2 Set up automatic logout

You can change the settings so that the device of a logged-in user automatically logs the user out after a certain period of inactivity.



These settings apply to all users. If you have activated the Auto login function for a user, then this user will not be automatically logged out.

1. Go to **Settings > Parameters > System > General**.
2. Select the desired parameter.
3. Set the parameter.
4. Press the **Accept** button to save the modified parameter.

#### Auto logout

You can use this parameter to activate the automatic logout function.

#### Time until auto logout

You can use this parameter to set the time period of inactivity after which a user is automatically logged out.

### 9.1.1.3 Activating/deactivating service user access

The device is equipped with user access for the Maschinenfabrik Reinhausen GmbH Technical Service department. This access is for error diagnostics and troubleshooting in the event of device faults.

You can use this parameter to activate or deactivate service user access. To safeguard IT security, only activate service user access for a limited time period for remedying faults.



If you deactivate the service user access and lose your password for the administrator role, it is not possible to reset the administrator password. If the administrator password is lost, the device must be reset to the default settings. When doing so, all information stored on the device (parameters, measured values, etc.) will be lost.

You must be assigned the administrator role to set parameters.



When in delivery status, you can log in as the administrator as follows:

- User name: `admin`
  - Password: `admin`
1. Go to **Settings > Parameters > System > General > Service user access activation**.
  2. Select the desired option.
  3. Press the **Accept** button to save the modified parameter.
  4. Restart the device to adopt the change.

#### Service user access activation

You can use this parameter to activate or deactivate service user access.

#### Control system protocol

You can use this parameter to set which control system protocol the device should use.

### 9.1.2 Configuring the network

You can use this menu item to configure the necessary network interface.

You must wire the device in accordance with the respective control system protocol [► Section 6.4.5, Page 47]. The following protocols are available:

- Modbus TCP
  - Modbus RTU
1. Go to **Settings > Parameters > System > Network settings**.
  2. Select the desired parameter.
  3. Set the parameter.
  4. Press the **Accept** button to save the modified parameter.

#### IP address

You can use this parameter to assign an IP address to the device.



Assign IP addresses to both web-based visualization and SCADA (optional) in different subnets. Otherwise you will not be able to establish a connection.

#### Subnet mask

You can use this parameter to set the subnet mask.



Be sure to enter a valid network mask that is not 0.0.0.0, otherwise it will not be possible to connect to the device.

**Gateway address**

You can use this parameter to set the gateway's IP address.



If you set the value to 0.0.0.0, no gateway is used.

**SSL/TLS encryption**

You can use this parameter to set whether the process for accessing the visualization should be carried out over an SSL/TLS-encrypted connection.

**TLS version**

You can use this parameter to set the accepted TLS versions. If you would like to establish an encrypted connection to the visualization, you must use an accepted TLS version. You can select the following options:

Option	Accepted TLS versions
>= 1.0	<ul style="list-style-type: none"> <li>▪ 1.0</li> <li>▪ 1.1</li> <li>▪ 1.2</li> </ul>
>= 1.1	<ul style="list-style-type: none"> <li>▪ 1.1</li> <li>▪ 1.2</li> </ul>
>= 1.2 <sup>1)</sup>	<ul style="list-style-type: none"> <li>▪ 1.2</li> </ul>

Table 14: TLS version

<sup>1)</sup> This option can be selected only if the TLS version is supported by the connected peripheral equipment.

**9.1.3 Setting the device time**

You can set the the device time manually or automatically via an SNTP time server. The device must be connected to an SNTP time server via Ethernet for this purpose.

1. Go to **Settings > Parameters > System > Time synchronization**.
2. Select the desired parameter.
3. Set the parameter.
4. Press the **Accept** button to save the modified parameter.



### Time synchronization via SNTP

You can use this parameter to activate time synchronization using an SNTP time server.

#### SNTP time server

You can use this parameter to enter the IP address of a SNTP time server. If you are using a time server, the device uses the time of the time server as the system time.



Be sure to enter a valid time server address that is not 0.0.0.0, otherwise it will not be possible to connect to the device.

#### Synchronization interval

You can use this parameter to set the interval at which the device is to call up the time from the time server.

#### Time zone

If the time information is transmitted to the device by a network service (SNTP or SCADA), this time is transferred depending on the set reference time. To adjust the device time to your local time, you can use the time shift parameter to set the time shift to UTC.

Example:

Region	Time shift to UTC
Mumbai, India	UTC +5:30 h
Beijing, China	UTC +8:00 h
Brasilia, Brazil	UTC -3:00 h

Table 15: Time shift to UTC (Coordinated Universal Time)

#### Time

You can use this parameter to set the date and time manually.

#### SNTP time server 2 (optional)

You can use this parameter to enter the IP address of the second time server (optional).

### 9.1.4 Setting the screensaver

To increase the service life of the display on the front panel of the device, you can activate and set a screensaver. The following functions are available for this purpose:

- Switching off the display
  - Dimming the brightness of the display
1. Go to **Settings > Parameters > System > Screensaver**.
  2. Select the desired parameter.
  3. Set the parameter.
  4. Press the **Accept** button to save the modified parameter.

#### Screensaver

If you activate this function, the device fully switches off the display when the adjustable waiting period has expired if no key is pressed. The display switches on again if you press any key.



Deactivating the screensaver has a negative impact on the service life of the display. Maschinenfabrik Reinhausen recommends that you activate the screensaver and set a waiting period of 15 minutes.

#### Screensaver waiting time

You can use this parameter to set the screensaver waiting time.

#### Dimming

When you activate this function, the device reduces the brightness of the display when the adjustable waiting time has expired if no key is pressed. The device then switches back to full brightness when you subsequently press any key.



If the screensaver and brightness dimming are activated, you have to press any key twice in order to reactivate the display at full brightness.

#### Dimming waiting time

You can use this parameter to set the dimming waiting time.

#### Brightness dimming

Setting for the brightness when the display is dimmed. 100% corresponds to full brightness, 10% to the lowest brightness.



### 9.1.5 Configuring syslog

The device supports the transmission of log messages via the syslog protocol in accordance with the standards RFC 5424 and RFC 3164.

1. Go to **Settings > Parameters > System > Syslog**.
2. Select the desired parameter.
3. Set the parameter.
4. Press the **Accept** button to save the modified parameter.

#### Activate syslog

You can use this parameter to activate transmission of syslog messages via the device.

#### Syslog standard

You can use this parameter to adjust the transmission process and the format for the syslog messages. You can select the following options:

Standard	Transport	Message format
RFC 5425 (recommended)	TLS	RFC 5424
RFC 5426	UDP	
RFC 6587	TCP	
RFC 3164	UDP	RFC 3164

Table 16: Syslog standard



If you use the standard RFC 5245 (TLS), you have to import the root certificate and the client certificate with the corresponding key to the syslog server. For more information, refer to the section titled Importing data.

#### Syslog server

You can use this parameter to set the IP address of the syslog server.

#### Syslog server port

You can use this parameter to set the port of the syslog server.

#### Reconnect delay time

You can use this parameter to determine how long the device will wait before it attempts to reconnect after the connection has been interrupted earlier or a syslog message could not be transmitted (only for TCP or TLS).

#### Device designation

You can use this parameter to set the device designation that the device will be identified with on the syslog server.



### Severity level

You can set which syslog messages the device will send. You can also activate or deactivate messages for each severity level.

Severity level	Description
Emergency	The system is unusable.
Alert	Immediate intervention required.
Critical	Critical state
Error	Error state
Warning	Warning state
Notice	Notice state
Info	Information state
Debug	Debug state

Table 17: Severity levels

### 9.1.6 SCADA

The following section describes how you can configure the device for connection to a control system (SCADA). You can download the data points with the help of the export manager [► Section 9.1.13, Page 85].

#### 9.1.6.1 Configuring Modbus

If you want to use the Modbus control system protocol, you must set the corresponding parameters depending on the Modbus type selected. Also refer to the section Configuring the network if you want to use Modbus TCP.

1. Go to **Settings > Parameters > System > Modbus**.
2. Select the desired parameter.
3. Set the parameter.
4. Press the **Accept** button to save the modified parameter.

#### Modbus type

You can use this parameter to set the Modbus type. You can select the following options:

- RTU
- TCP
- ASCII

#### TCP port

You can use this parameter to set the TCP port.



**Receiver IP address**

You can use this parameter to set the IP address of the receiver.

**Modbus address**

You can use this parameter to set the Modbus address.

**Serial interface**

You can use this parameter to select the serial interface for data transmission. You can select the following options:

- RS232
- RS485

**Baud rate**

You can use this parameter to set the serial interface's baud rate. You can select the following options:

- 9600 baud
- 19200 baud
- 38400 baud
- 57600 baud
- 115200 baud

**9.1.7 Linking signals and events**

The device enables you to link 12 digital inputs (GPI) and control system commands (SCADA) with device functions, digital outputs (GPO) and control system messages.

The digital inputs available are each permanently linked to a *General purpose input* event message and the control system commands available are each permanently linked to a *Generic SCADA command* event message for this purpose.

Input/command	Event message
Digital input 1	General purpose input 1
Digital input 2	General purpose input 2
...	...
Generic SCADA command 1	Generic SCADA command 1
Generic SCADA command 2	Generic SCADA command 2
...	...

Table 18: Linking of digital inputs and control system commands with event messages

You can link the event messages with device functions, digital outputs and control system messages. You can also link all other event messages (e.g. *Undervoltage U<*) with digital outputs and control system messages. Corresponding parameters, for which you need to enter the relevant event number, are provided for this purpose.

### 9.1.7.1 Linking functions

You can link the *General purpose input* or *Generic SCADA command* events with device functions. This allows you to remotely control the device using digital inputs or commands via the control system (SCADA).

To establish the link, you have to enter the corresponding event number in the desired parameter.



Note that you can only enter the event numbers of the *General purpose input* or *Generic SCADA command* events.

If you enter event number 500, the link is disabled.

✓ The desired event number is known [► Section 9.1.9, Page 79].

1. Go to **Settings > Parameters > System > Link functions**.
2. Select the desired parameter.
3. Enter the desired event number.
4. Press the **Accept** button to save the modified parameter.

#### Master parallel operation method

If the assigned event is active, the device activates the master parallel operation method.

#### Follower parallel operation method

If the assigned event is active, the device activates the follower parallel operation method.

#### Automatic tap synchronization parallel operation method

If the assigned event is active, the device activates the automatic tap synchronization parallel operation method.

#### Independent regulation

If the assigned event is active, the device activates the independent regulation independent mode.

#### Blocking

If the assigned event is active, automatic control is blocked.



**High-speed return**

If the assigned event is active, the device activates high-speed return. With high-speed return, the device ignores the set delay time of automatic voltage regulation.

**Target-tap-position operation**

If the assigned event is active, the device switches to the defined target tap position.

**Activate desired value 1**

If the assigned event is active, the device activates the desired value 1.

**Activate desired value 2**

If the assigned event is active, the device activates the desired value 2.

**Activate desired value 3**

If the assigned event is active, the device activates the desired value 3.

**9.1.7.2 Linking digital outputs**

You can link each event with a digital output. The device provides 12 digital outputs (GPO) for this purpose. When you link a digital output to an event, the device issues a signal to this output if the event occurs. The signal persists until the event stops. A parameter is available for each available digital output.



To forward input signals or control system commands, you need to link the digital outputs or control system messages with the *General purpose input* or *Generic SCADA command* events.

✓ The desired event number is known.

1. Go to **Settings > Parameters > System > Link outputs**.
2. Select the desired parameter.
3. Enter the desired event number.
4. Press the **Accept** button to save the modified parameter.

**Generic digital output X**

You can use this parameter to link the digital output with an event message. To do so, enter the desired event number.



If you enter event number 500, the link is disabled.

### 9.1.7.3 Linking status messages

You can link each event with a status message. The device provides 10 generic status messages for this purpose. When you link a message to an event, the device sets the data point to "On" when the event occurs. When the event stops, the device sets the data point to "Off". A parameter is available for each available SCADA message.



To forward control system commands, you need to link the control system messages to the *General purpose input* or *Generic SCADA command* events.

✓ The desired event number is known [► Section 9.1.9, Page 79].

1. Go to **Settings > Parameters > System > Link messages**.
2. Select the desired parameter.
3. Enter the desired event number.
4. Press the **Accept** button to save the modified parameter.

#### Generic status message X

You can use this parameter to link the SCADA message with an event message. To do so, enter the desired event number.



If you enter event number 500, the link is disabled.

### 9.1.8 Configuring digital inputs and outputs

Upon delivery, the configurable digital inputs and outputs of the device are configured as follows:

- Input: High active
- Output: N/O contact (NO)

You can change this configuration if necessary.



Ensure that the configuration of the digital inputs and outputs is suitable for the functions used. Otherwise, malfunctions may occur in the device and the connected periphery.



The following information is displayed in tabular form for configuring the digital inputs and outputs. Grayed-out elements cannot be changed.

Property	Options
Function	Function of the digital input (I: ...) or the digital output (O: ...). You can adjust the designation.
Signal type	Select signal type: Digital input
Configuration	DI: High active or low active DO: N/O contact (NO), N/C contact (NC); Note: If the device is disconnected or in the event of an error, the digital outputs are always open (no bi-stable relay).
Assembly/channel	Channel of the DI/DO interfaces to which the function is linked. Functions that are not linked with a channel are identified with "-". Note the connection diagram supplied.

Table 19: Configuration of the digital inputs and outputs



The operation described below is only possible if you access the visualization using a computer. You can only change the configuration of the digital inputs and outputs if you have a Parameter Configurator or Administrator role.

When in delivery status, you can log in as the administrator as follows:

- User name: admin
- Password: admin

**Creating a backup** You need to create a backup to be able to reset the system in the event that any incorrect configuration settings are made. To do so, proceed as follows:

1. Go to **Settings > Export**.
2. Go to the option **Settings** to export a backup copy of the current settings.
3. Select the desired **Interface** (USB or PC).
4. Press the **Export** button to start the export.

**DI/DO configuration**

1. Go to **Settings > DI configuration/DO configuration**.
2. Where necessary, select the buttons ▲ or ▼ to sort the properties in a column alphabetically.
3. Configure the properties as desired.
4. Press the **Accept** button.
5. Confirm the security prompt with **Yes** to save the changes.

### 9.1.9 Event management

The device is equipped with event management, which allows you to detect various device operating statuses and to adapt the behavior of the device. An overview of all possible events is given in the Event messages chapter.

### 9.1.9.1 Displaying and acknowledging events

#### Displaying events

- ▶ Go to **Events**.

⇒ A list of currently pending events appears.

#### Acknowledging events

Acknowledgeable events must be acknowledged in the event overview so that they are no longer displayed. All other events are automatically removed once the cause has been fixed (e.g. limit value is no longer exceeded).

To acknowledge the events, proceed as follows:

- ▶ To acknowledge the events, highlight the desired events in the  column, then press the **Acknowledge** button.

⇒ The events have been acknowledged.

### 9.1.9.2 Displaying event memory

Past events are stored in the event memory. The following information is displayed:



Column	Description
#	Consecutive number of events
No.	Event number for clear identification
	Event category: <ul style="list-style-type: none"> <li>▪ Error (red)</li> <li>▪ Warning (yellow)</li> <li>▪ Info (gray)</li> </ul>
Event	Event text
Time	Date and time of event (DD-MM-YYYY, HH:MM:SS/ms)
	Event coming/going: <ul style="list-style-type: none"> <li>➤ Event coming</li> <li>➤ Event going</li> </ul>

Table 20: Event memory

1. Go to **Events**.
2. Press the **Log** button.

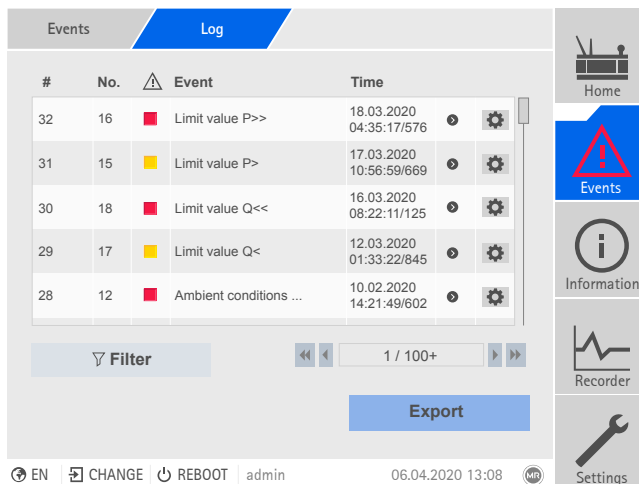

Figure 43: Event memory

### Filtering events

1. Press the **Filter** button.
2. Enter the desired time period.
3. Select the checkbox and enter the desired event number.  
⇒ The event text is displayed.
4. Select the desired event categories and the desired event status.
5. Press the **Search** button to display the desired events.

### Exporting events

You can export the event memory entries currently displayed as a csv file. If you first create a filter, only the filtered entries are exported.

To export the events, proceed as follows:

- ✓ First connect using Connect PC or connect a storage medium to the USB port on the CPU I module.
1. Press the **Export** button.
  2. Select the desired option for data transmission (PC or USB).  
⇒ The data is exported.

### 9.1.10 User administration

User administration is based on a system of roles. You must assign a role to every user. You can define access rights to parameters and events for each role.



### 9.1.10.1 Activating/deactivating service user access

The device is equipped with user access for the Maschinenfabrik Reinhausen GmbH Technical Service department. This access is for error diagnostics and troubleshooting in the event of device faults.

You can use this parameter to activate or deactivate service user access. To safeguard IT security, only activate service user access for a limited time period for remedying faults.



If you deactivate the service user access and lose your password for the administrator role, it is not possible to reset the administrator password. If the administrator password is lost, the device must be reset to the default settings. When doing so, all information stored on the device (parameters, measured values, etc.) will be lost.

You must be assigned the administrator role to set parameters.

When in delivery status, you can log in as the administrator as follows:

- User name: `admin`
  - Password: `admin`
1. Go to **Settings > Parameters > System > General > Service user access activation**.
  2. Select the desired option.
  3. Press the **Accept** button to save the modified parameter.
  4. Restart the device to adopt the change.

### 9.1.10.2 User roles

The access rights to the device functions and settings are controlled using a hierarchical system of roles. The system has five different roles with different access rights. Some of these access rights are fixed, but you can configure the access rights to particular parameters and events. Note the Setting access rights to parameters and events section.



If you are not logged in on the device, you will assume the "Data display" user role.



Upon delivery, the following roles are provided:

Role	Description
Data display	User who can only view data of relevance to operation. <ul style="list-style-type: none"> <li>▪ Display all parameters</li> <li>▪ Display all events</li> </ul>
Diagnostics	User who can view data and log data of relevance to operation. <ul style="list-style-type: none"> <li>▪ Display all parameters</li> <li>▪ Display all events</li> <li>▪ Export log data</li> </ul>
Operator	User who can view data of relevance to operation and acknowledge events. The user can perform manual tap-change operations using the device's controls. <ul style="list-style-type: none"> <li>▪ Display all parameters</li> <li>▪ Display and acknowledge all events</li> </ul>
Parameter configurator	User who can view and modify data of relevance to operation. <ul style="list-style-type: none"> <li>▪ Display and modify all parameters</li> <li>▪ Import and export parameters</li> <li>▪ Display, modify, and acknowledge all events</li> </ul>
Administrator	User who can view and modify all data. <ul style="list-style-type: none"> <li>▪ Read all parameters</li> <li>▪ Display, modify, and acknowledge all events</li> </ul>

Table 21: Roles in delivery status

Access to the following areas of the device is linked to the roles:

Function	Data display	Diagnostics	Operator	Parameter configurator	Administrator
Administration	-	-	-	-	+
Restart device	-	-	+	+	+
Import	-	-	-	+	+
Export	-	+	-	+	+
Set date and time	-	-	+	+	+
Calibrate resistor contact series	-	-	-	+	+
Actuation of the RAISE, LOWER, REMOTE, AVR AUTO, and AVR MANUAL keys	-	-	+	+	+
Configuring analog inputs	-	-	-	+	+
Configuring digital inputs and outputs	-	-	-	+	+

Table 22: Access rights permanently linked to the roles



### 9.1.10.3 Changing password

All users can change their passwords provided that the user account is not set up as a group account. You can only change a group account's password if you are logged in as the administrator.

Note that the password must satisfy the following requirements:

- At least eight characters
- At least three of the four following character types
  - Upper case letters
  - Lower case letters
  - Numbers
  - Special characters

1. Select the **user name** in the status line.
2. Enter the new **password** twice.
3. Press the **Accept** button to save the changed password.

### 9.1.10.4 Creating, editing and deleting users

Adjustable options

- Username and password
- Role: You can assign a role to every user. The access rights to parameters and events are linked to the roles.
- Group account: With this option, you can declare a user account to be a group account (e.g. for access by different people). Users with a group account cannot change their own password. The password can only be changed by the administrator.
- Active: You can activate or deactivate the user. Deactivated users cannot log in. The user data is still stored in the device.
- Auto login: You can activate the Auto-login function for a user. This user is automatically logged in when the system is restarted or another user logs out.



You can only create, edit, and delete users if you are assigned an administrator role.

When in delivery status, you can log in as the administrator as follows:

- User name: `admin`
- Password: `admin`

#### Creating users

1. Go to **Settings > Administration > User**.
2. Press the **Create user** button.
3. Enter the **user name** once and the **password** twice.



4. Select the **role** you want.
5. If necessary, activate the **Group account**, **Active** or **Auto login** options.
6. Press the **Accept** button to save the user.

#### **Editing users**

1. Go to **Settings > Administration > User**.
2. Select the desired user in the list.
3. Make the amendments desired.
4. Press the **Accept** button to save the user.

#### **Deleting a user**

1. Go to **Settings > Administration > User**.
2. Select the desired user in the list.
3. Press the **Delete user** button.
4. Press the **Accept** button to delete the user.

### **9.1.11 Hardware**

Under Hardware, you can display information about the device's hardware. You will find information about the signal level of the individual channels for the assemblies.

1. Go to **Information > System > Hardware**.
2. Select the desired **Assembly** in order to display the signal levels of the channels.

### **9.1.12 Software**

Under Software, you can display the version status of the software components of the device.

- ▶ Go to **Information > System > Software**.

### **9.1.13 Import/export manager**

The device is equipped with an import/export manager which can be used to transmit data using a PC via the web-based visualization system.

#### **9.1.13.1 Exporting data**

You can export the following data from the device:



Option	Description
System image	Complete image of the system (software and configuration). If you are using the option "with history", all of the event memory entries are also exported.
System configuration	System configuration
Event log	All event memory entries.
Parameter list	Parameter list with descriptive text and values (min, max, current).
Event list	Complete list of all possible events.
SCADA configuration	Control system configuration
Operating instructions	Operating instructions, protocol specifications.
Settings	Configuration of parameters and events.
Security log	Logbook of all instances of access and changes relating to security.
Licenses	Copyright and disclaimers of the software components used.

Table 23: Exporting data

1. Go to **Settings > Export**.
2. Select the desired option for the export.



### 9.1.13.2 Importing data

You can import the following data:

Option	Description
System image	Complete image of the system (software and configuration), with or without history.
Settings	All device settings: <ul style="list-style-type: none"> <li>▪ Parameter settings</li> <li>▪ Event settings</li> <li>▪ Administrative settings (users, access rights)</li> </ul> The settings can also be imported from another device.
SSL certificate	Import of an SSL certificate with associated key: <ul style="list-style-type: none"> <li>▪ Server certificate (.crt + .pem)</li> <li>▪ Client certificate (.crt + .pem)</li> <li>▪ Client CA (.crt)</li> </ul> For the import, you will have to compress the certificate (*.crt) and key (*.pem) in a zip file. You can import certificates with the following key authentication: <ul style="list-style-type: none"> <li>▪ RSA with 1024 bits</li> <li>▪ ECDSA with 256 bits ("secp256r1" or "prime256v1" curve).</li> </ul>

Table 24: Importing data

**NOTICE**

**Damage to the file system!**

The file system can become damaged due to an incorrect data transmission process. A damaged file system can lead to the device no longer being functional.

► Do not disconnect the device from the power supply during the import.

1. Go to **Settings > Import**.
2. Press the **Browse** button, select the file to be imported and then press the **Start upload** button.
  - ⇒ The file is checked.
3. Press the **Start update** button to start the import.
4. Press the **OK** button to restart the device following a successful import.



## 9.2 Power grid

### 9.2.1 Transformer data

The transformation ratios and measuring set-up for the voltage and current transformers used in the system can be set with the following parameters. The device uses this information to calculate the corresponding measured values on the primary side of the current transformer (and therefore the transformer) from the recorded measured values. These are then displayed.

#### 9.2.1.1 Setting transformer data

You can use the following parameters to set the transformer data. Also note the Examples for standard circuits for current transformers and voltage transformers.

1. Go to **Settings > Parameters > Grid > Transformer data**.
2. Select the desired parameter.
3. Set the desired parameter.
4. Press the **Accept** button to save the modified parameter.

##### 9.2.1.1.1 Nominal voltage measuring range

You can use this parameter to set the measuring range of the nominal voltage. Since a voltage transformer is not connected upstream of the TAPCON® 230 AVT, you can set the following measuring ranges:

Setting	Range of values
230 V	20...280 V
400 V <sup>1)</sup>	20...510 V

Table 25: Ranges

<sup>1)</sup> Factory setting

After each time this parameter is changed, check all set voltage parameters and adjust them if necessary.

#### Primary transformer current

You can use this parameter to set the primary current of the current transformer.

#### Secondary transformer current

You can use this parameter to set the secondary current of the current transformer. You can select the following options:

- 1 A
- 5 A



**Phase angle correction**

You can use this parameter to set the phase angle correction for your transformer circuit.

**Voltage-transformer circuit**

You can use this parameter to set your voltage transformer's circuit. You can select the following options:

Option	Description
1 Ph phase voltage	Measurement in 1-phase grid between the conductor and neutral conductor.
3 Ph differential voltage	Measurement in 3-phase grid between 2 conductors
3 Ph phase voltage	Measurement in 3-phase grid between the conductor and neutral conductor

Table 26: Voltage-transformer circuit

**Current-transformer circuit**

You can use this parameter to set the circuit for your current transformer. You can select the following options:

Option	Description
1 Ph phase current	Measurement of phase current in 1-phase grid.
3 Ph total current	Measurement of differential current in 3-phase grid.
3 Ph phase current	Measurement of phase current in 3-phase grid.

Table 27: Current-transformer circuit

**9.2.1.2 Circuit examples for voltage transformers and current transformers**

Below you will find different examples of circuits for voltage transformers and current transformers and the corresponding settings.

9.2.1.2.1 1-phase measurement

Circuit 1-A

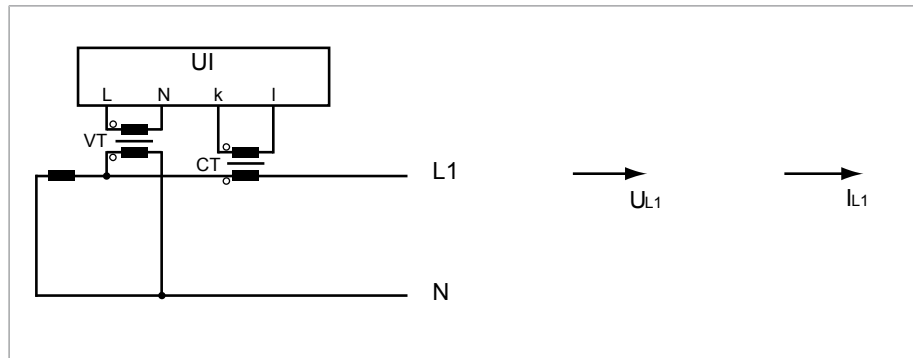

Figure 44: Circuit 1-A

- The voltage transformer VT is connected to the phase conductor and the neutral conductor.
- The current transformer CT is looped into the phase conductor.
- The voltage  $U_{L1}$  and current  $I_{L1}$  are in phase.
- The voltage drop on a phase conductor is determined by the current  $I_{L1}$ .

If you use this circuit, set the device as follows:

Parameter	Option
Voltage-transformer circuit	1 Ph phase voltage
Current-transformer circuit	1 Ph phase current
Phase angle correction	0°

Table 28: Circuit 1-A

Circuit 1-B

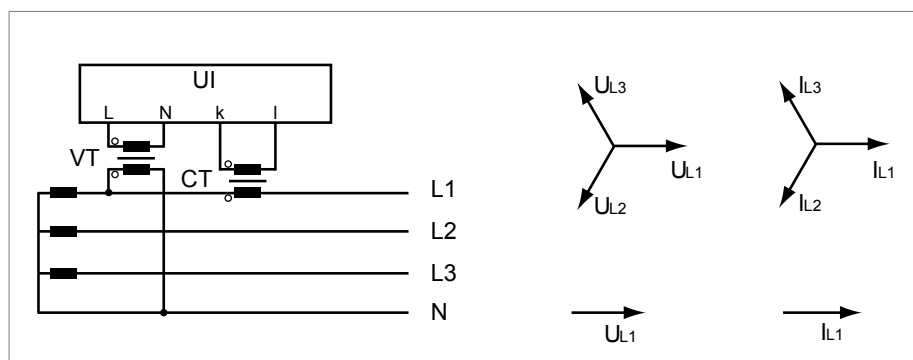

Figure 45: Circuit 1-B

- The voltage transformer VT is connected to the phase conductor L1 and the neutral conductor.
- The current transformer CT is looped into the phase conductor L1.

- The voltage  $U$  and current  $I$  are in phase.
- The voltage drop on a phase conductor is determined by the current  $I_{L1}$ .

If you use this circuit, set the device as follows:

Parameter	Option
Voltage-transformer circuit	3 Ph phase voltage
Current-transformer circuit	3 Ph phase current
Phase angle correction	0°

Table 29: Circuit 1-B

### Circuit 1-C

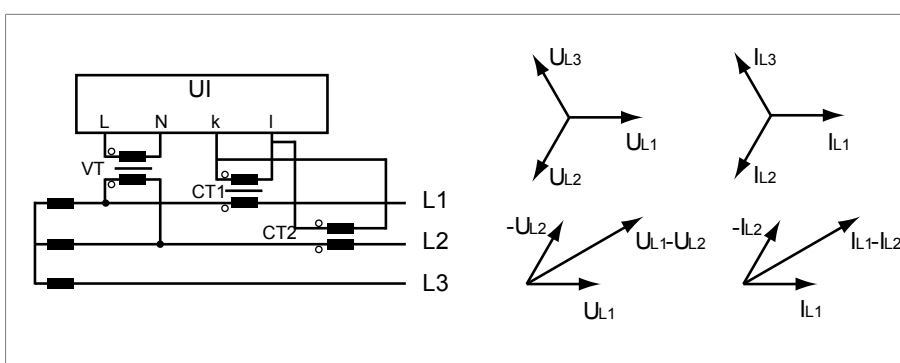

Figure 46: Circuit 1-C

- The voltage transformer VT is connected to the phase conductors L1 and L2.
- The current transformer CT1 is looped into the phase conductor L1 and CT2 is looped into the phase conductor L2.
- The current transformers CT1 and CT2 are connected crosswise in parallel (total current =  $I_{L1} + I_{L2}$ ).
- The total current  $I_{L1} + I_{L2}$  and voltage  $U_{L1}-U_{L2}$  are in phase.
- The voltage drop on a phase conductor is determined by the current:  $(I_{L1} + I_{L2}) / \sqrt{3}$ .

If you use this circuit, set the device as follows:

Parameter	Option
Voltage-transformer circuit	3 Ph differential voltage
Current-transformer circuit	3 Ph total current
Phase angle correction	0°

Table 30: Circuit 1-C

**Circuit 1-D**

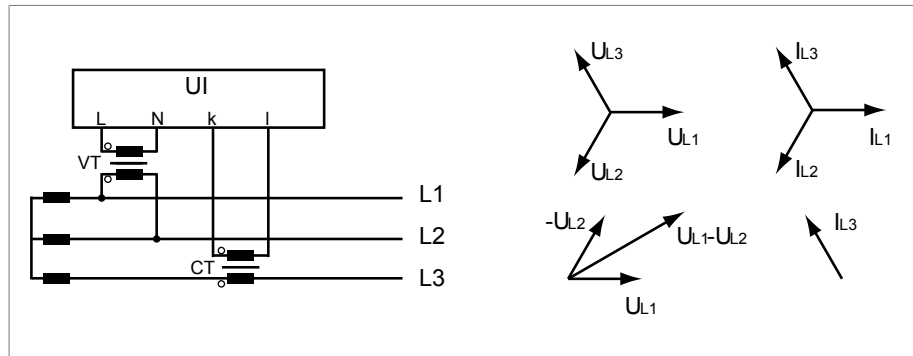

Figure 47: Circuit 1-D

- The voltage transformer VT is connected to the phase conductors L1 and L2.
- The current transformer CT is looped into the phase conductor L3.
- The current  $I_{L3}$  is ahead of voltage  $U_{L1-U_{L2}}$  by  $90^\circ$ . This corresponds to a phase shift of  $-90^\circ$ .
- The voltage drop on a phase conductor is determined by the current  $I_{L3}$ .

If you use this circuit, set the device as follows:

Parameter	Option
Voltage-transformer circuit	3 Ph differential voltage
Current-transformer circuit	3 Ph phase current
Phase angle correction	$90^\circ$

Table 31: Circuit 1-D

**Circuit 1-E**

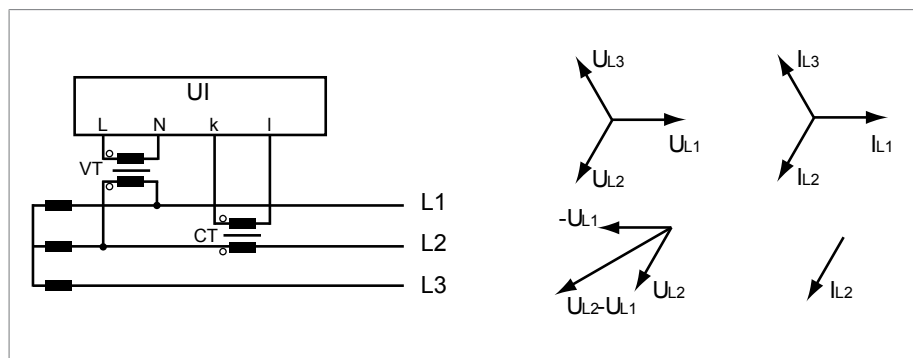

Figure 48: Circuit 1-E

- The voltage transformer VT is connected to the phase conductors L1 and L2.
- The current transformer CT is looped into the phase conductor L2.

- The current  $I_{L2}$  is ahead of voltage  $U_{L2}-U_{L1}$  by  $30^\circ$ . This corresponds to a phase shift of  $-30^\circ$ .
- The voltage drop on a phase conductor is determined by the current  $I_{L2}$ .

If you use this circuit, set the device as follows:

Parameter	Option
Voltage-transformer circuit	3 Ph differential voltage
Current-transformer circuit	3 Ph phase current
Phase angle correction	$30^\circ$

Table 32: Circuit 1-E

### Circuit 1-F

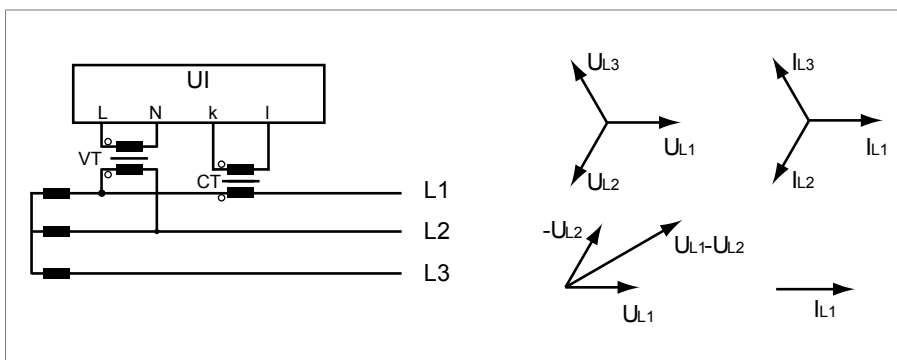

Figure 49: Circuit 1-F

- The voltage transformer VT is connected to the phase conductors L1 and L2.
- The current transformer CT is looped into the phase conductor L1.
- The current  $I_{L1}$  lags behind voltage  $U_{L1}-U_{L2}$  by  $30^\circ$ . This corresponds to a phase shift of  $+30^\circ$  and a correction value of  $-30^\circ$ .
- The voltage drop on a phase conductor is determined by the current  $I_{L1}$ .

If you use this circuit, set the device as follows:

Parameter	Option
Voltage-transformer circuit	3 Ph differential voltage
Current-transformer circuit	3 Ph phase current
Phase angle correction	$-30^\circ$

Table 33: Circuit 1-F

### 9.2.2 Voltage monitoring

In order to monitor the transformer's current output voltage, you can set 4 limit values:

- Undervoltage  $U \ll$ : Lower limit 2
- Undervoltage  $U <$ : Lower limit 1

- Overvoltage  $U>$ : Upper limit 1
- Overvoltage  $U>>$ : Upper limit 2

If the measured value is higher than the upper limit ( $>$  or  $>>$ ) or lower than the lower limit ( $<$  or  $<<$ ), the device transmits an event message.

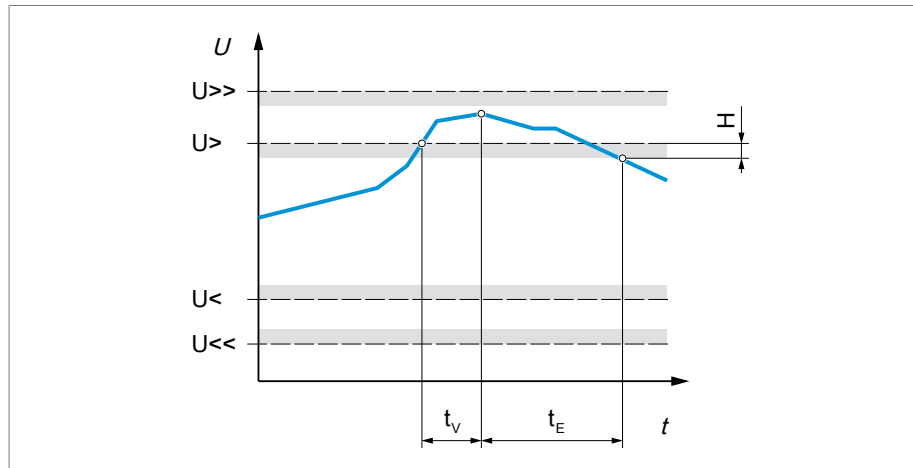

Figure 50: Example of voltage monitoring with the limit value Overvoltage  $U>$  being exceeded

$U>>$ Overvoltage $U>>$	$U>$ Overvoltage $U>$
$U<$ Undervoltage $U<$	$U<<$ Undervoltage $U<<$
$t_v$ Delay time	$t_E$ Event duration
H Hysteresis	

1. Go to **Settings > Parameters > Grid > Voltage monitoring**.
2. Select the desired parameter.
3. Set the desired parameter.
4. Press the **Accept** button to save the modified parameter.

You can set additional parameters for each limit value:

### Mode

You can use this parameter to set which limit value you would like to use:

- Absolute: The device uses the absolute limit value in V.
- Relative: The device uses the relative limit value in %, relative to the desired voltage value.



### Reaction

You can use this parameter to set the behavior of the device if the measured value is higher than the upper limit (> or >>) or lower than the lower limit (< or <<). You can select the following options:

Setting	Behavior
Off	No reaction.
High-speed return	<p>For <math>U &lt; U_{&lt;&lt;}</math>: The device performs tap-change operations in the raise voltage direction (U+) until the measured voltage is back above the limit value.</p> <p>For <math>U &gt; U_{&gt;&gt;}</math>: The device performs tap-change operations in the lower voltage direction (U-) until the measured voltage is back below the limit value.</p> <p>With high-speed return, the device ignores the set delay time of automatic voltage regulation.</p>
Auto blocking	<p>Automatic regulation is blocked.</p> <p>You can continue to perform tap-change operations in manual mode.</p>
Auto/manual blocking	<p>Automatic regulation is blocked.</p> <p>You <b>cannot</b> perform tap-change operations in manual mode.</p>

Table 34: Behavior when an event message is issued

### Hysteresis

You can use this parameter to set the hysteresis. You can use this to avoid the unnecessary generation of messages if the measured value fluctuates around a threshold value.

### Delay time

You can use this parameter to set the delay time in order to delay the issuing of the event message.

#### 9.2.3 Current monitoring

For monitoring the transformer's current load current, you can set 4 limit values:

- $I_{<<}$ : Lower limit 2
- $I_{<}$ : Lower limit 1
- $I_{>}$ : Upper limit 1
- $I_{>>}$ : Upper limit 2

If the measured value is higher than the upper limit (> or >>) or lower than the lower limit (< or <<), the device transmits an event message.

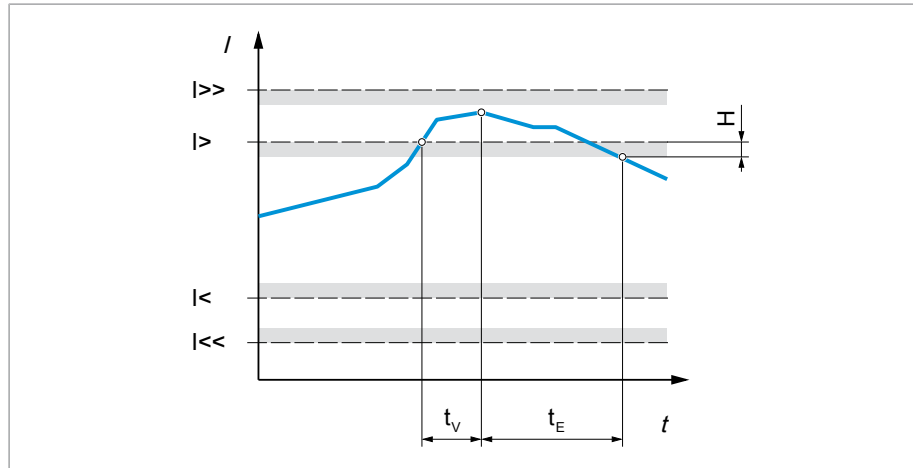

Figure 51: Example of current monitoring with the limit value  $I>$  being exceeded

$I>>$ Upper limit 2	$I>$ Upper limit 1
$I<$ Lower limit 1	$I<<$ Lower limit 2
$t_v$ Delay time	$t_E$ Event duration
H Hysteresis	

1. Go to **Settings > Parameters > Grid > Current monitoring**.
2. Select the desired parameter.
3. Set the desired parameter.
4. Press the **Accept** button to save the modified parameter.

You can set additional parameters for each limit value:

### Mode

You can use this parameter to set which limit value you would like to use:

- Absolute: The device uses the absolute limit value in A/kA.
- Relative: The device uses the relative limit value in %, relative to the rated current of current transformer.

### Hysteresis

You can use this parameter to set the hysteresis. You can use this to avoid the unnecessary generation of messages if the measured value fluctuates around a threshold value.

### Delay time

You can use this parameter to set the delay time in order to delay the issuing of the event message.



### Reaction

You can use this parameter to set the behavior of the device if the measured value is higher than the upper limit (> or >>) or lower than the lower limit (< or <<). You can select the following options:

Setting	Behavior
Off	No reaction.
Auto blocking	Automatic regulation is blocked. You can continue to perform tap-change operations in manual mode.
Auto/manual blocking	Automatic regulation is blocked. You <b>cannot</b> perform tap-change operations in manual mode.

Table 35: Behavior when an event message is issued

### 9.2.4 Power monitoring

For monitoring the transformer's current power, you can set the following limit values:

Measured value	Lower limit 2	Lower limit 1	Upper limit 1	Upper limit 2
Apparent power	S<<	S<	S>	S>>
Active power	P<<	P<	P>	P>>
Reactive power	Q<<	Q<	Q>	Q>>
Power factor (amount)	cos φ <<	cos φ <	-	-

Table 36: Limit values for power monitoring

1. Go to **Settings > Parameters > Grid > Power monitoring**.
2. Select the desired parameter.
3. Set the desired parameter.
4. Press the **Accept** button to save the modified parameter.

You can set additional parameters for each limit value:

#### Absolute

You can use this parameter to specify a limit value.

#### Hysteresis

You can use this parameter to set the hysteresis. You can use this to avoid the unnecessary generation of messages if the measured value fluctuates around a threshold value.



### Delay time

You can use this parameter to set the delay time in order to delay the issuing of the event message.

### Reaction

You can use this parameter to set the behavior of the device if the measured value is higher than the upper limit (> or >>) or lower than the lower limit (< or <<). You can select the following options:

Setting	Behavior
Off	No reaction.
Auto blocking	Automatic regulation is blocked. You can continue to perform tap-change operations in manual mode.
Auto blocking position-	The automatic control does not perform a tap-change operation in the direction of a lower tap position (position-). You can continue to perform tap-change operations in manual mode.
Auto blocking position+	The automatic control does not perform a tap-change operation in the direction of a higher tap position (position+). You can continue to perform tap-change operations in manual mode.
Auto/manual blocking	Automatic regulation is blocked. You <b>cannot</b> perform tap-change operations in manual mode.
Auto/manual blocking position-	The automatic control does not perform a tap-change operation in the direction of a lower tap position (position-). You <b>cannot</b> perform a tap-change operation in the direction of a lower tap position (position-) in manual mode.
Auto/manual blocking position+	The automatic control does not perform a tap-change operation in the direction of a higher tap position (position+). You <b>cannot</b> perform a tap-change operation in the direction of a higher tap position (position+) in manual mode.

Table 37: Behavior when an event message is issued



### 9.2.5 Power flow monitoring

A reversal of power flow occurs if the active power is negative. You can set the following parameters for this:

- Hysteresis
- Delay time
- Behavior

1. Go to **Settings > Parameters > Grid > Power flow monitoring**.
2. Select the desired parameter.
3. Set the desired parameter.
4. Press the **Accept** button to save the modified parameter.

#### Hysteresis

You can use this parameter to set the hysteresis. You can use this to avoid the unnecessary generation of messages if the measured value fluctuates around a threshold value.

#### Delay time

You can use this parameter to set the delay time in order to delay the issuing of the event message.

#### Behavior for reversal of power flow

You can use this parameter to set the behavior in the event of a reversal of power flow. You can select the following options:

Setting	Behavior
Off	<ul style="list-style-type: none"> <li>▪ The negative power flow is ignored.</li> <li>▪ Automatic regulation remains active.</li> </ul>
Event only	<ul style="list-style-type: none"> <li>▪ The <i>Reversal of power flow</i> event is issued.</li> <li>▪ Automatic regulation remains active.</li> </ul>
Auto blocking	<ul style="list-style-type: none"> <li>▪ The <i>Reversal of power flow</i> event is issued.</li> <li>▪ Automatic regulation is blocked.</li> </ul>

Setting	Behavior
Auto/manual blocking	<ul style="list-style-type: none"> <li>The <i>Reversal of power flow</i> event is issued.</li> <li>Automatic regulation is blocked.</li> <li>You cannot perform tap-change operations in manual mode.</li> </ul>
Target tap position	<ul style="list-style-type: none"> <li>The <i>Reversal of power flow</i> event is issued.</li> <li>The device triggers a tap-change operation to the tap position you defined in the "Target tap position" parameter.</li> <li>The device blocks further tap-change operations.</li> <li>The target-tap-position operation is ignored if there is no tap-position capture. Automatic regulation is blocked.</li> </ul>

Table 38: Behavior in the event of a reversal of power flow

### 9.2.6 TAPCON® 2xx retrofit

The TAPCON® 2xx retrofit function allows you to operate the device in parallel operation with existing devices. Parallel operation with the following existing devices is supported:

- Predecessor devices: TAPCON® 230 pro/expert
- TAPCON® 240
- TAPCON® 250
- TAPCON® 260
- TRAFOGUARD® with "Voltage regulation" options package

If you wish to operate several devices in parallel operation with existing devices, you have to activate the TAPCON® 2xx retrofit function on each device.

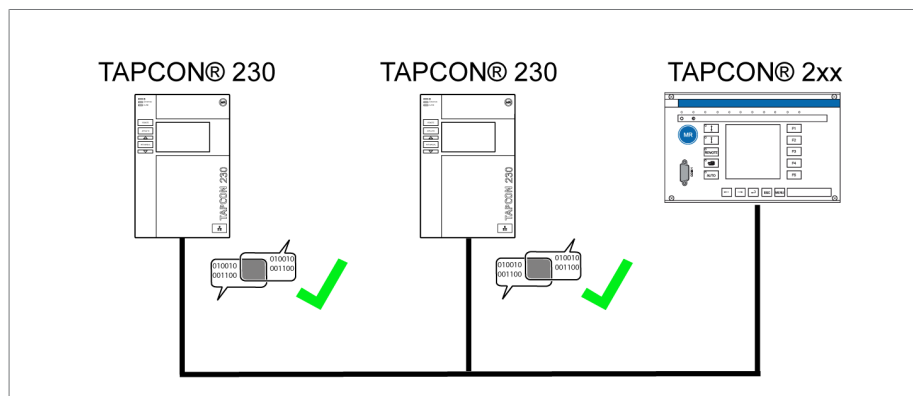

Figure 52: Parallel operation of 2 devices with one TAPCON® 2xx

1. Go to **Settings > Parameters > Grid > TAPCON® 2xx retrofit**.
2. Select the desired parameter.
3. Set the desired parameter.



4. Press the **Accept** button to save the modified parameter.

**TAPCON® 2xx retrofit**

You can use this parameter to activate or deactivate the Retrofit TAPCON® 2xx function.



If you activate this parameter, you have to reverse the prefix of the "Phase angle correction" parameter for the transformer data (from - to + or from + to -).

## 9.3 On-load tap-changer regulator

### 9.3.1 Voltage regulation

All of the parameters required for the control function are described in this section.

1. Go to **Settings > Parameters > On-load tap-changer regulator > Voltage regulation**.
2. Select the desired parameter.
3. Set the desired parameter.
4. Press the **Accept** button to save the modified parameter.

#### 9.3.1.1 Setting the desired value

You can set three different desired values. The device always uses one of the set desired values for control. You can define which desired value is used for regulation with the "Change remote desired value setting" parameter. You can define up to 3 desired values.



The device only processes commands via digital inputs or the control system when it is in the Remote mode. You must also set the Remote behavior [► Page 67] parameter accordingly.

#### Setting desired value 1...3

You can set the desired value with this parameter.

1. Go to **Settings > Parameters > On-load tap-changer > Voltage regulation > Desired value**.
2. Enter the desired value.
3. Press the **Accept** button to save the modified parameter.

#### Changing the remote desired value setting

You can use this parameter to select the type of remote desired value setting which the device is to use for regulation. You can select between 3 options:

- Remote desired value setting using 3 digital desired values
  - For this option, make sure that the corresponding digital inputs are connected.
- Remote desired value setting using analog desired values
  - For this option, make sure that the corresponding analog input is connected.
- Remote desired value setting using TDSC

1. Go to **Settings > Parameters > On-load tap-changer > Voltage regulation > Change remote desired value setting**.
2. Select the desired option in the list.
3. Press the **Accept** button to save the modified parameter.

#### Selecting a desired value

You can use this parameter to select the desired value used for control. You can choose between desired value 1, desired value 2 and desired value 3.

✓ Type of remote desired value setting [▶ Page 102] selected.

1. Go to **Settings > Parameters > On-load tap-changer > Voltage regulation > Desired value**.
2. Select the desired value from the list.
3. Press the **Accept** button to save the modified parameter.

#### 9.3.1.1.1 Analog setting of the desired value

With the analog setting of the desired value, the desired value for the automatic voltage regulation can be variably adapted using an analog signal (e.g. 4...20 mA).

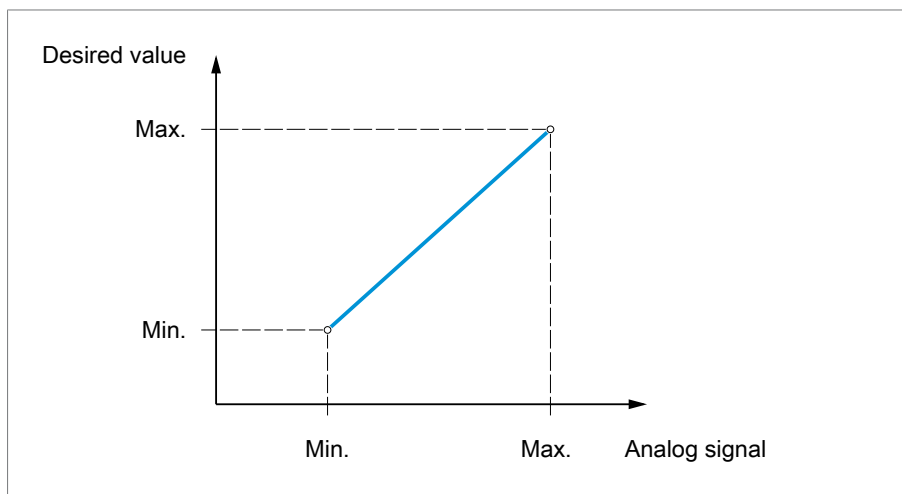

Figure 53: Analog setting of the desired value

In order to configure the analog setting of the desired value, you can set the parameters as described below.



To specify the desired value using an analog signal, you need to create a signal at the *Desired value setting release* input. If this is not done, the device uses the set desired value 1.

#### Setting desired value 1

1. Go to **Settings > Parameters > Grid > Control > Desired value**.
2. Enter the desired value.



3. Press the **Accept** button to save the modified parameter.

**Setting max. desired value setting**

With this parameter, you can set the desired value that corresponds to the maximum level of the analog signal level (e.g. 20 mA for 4...20 mA signal).

1. Go to **Settings > Parameters > Control > Setting max. desired value**.
2. Enter desired value.
3. Press the **Accept** button to save the modified parameter.

**Setting min. desired value setting**

With this parameter, you can set the desired value that corresponds to the minimum level of the analog signal (e.g. 4 mA for 4...20 mA signal).

1. Go to **Settings > Parameters > Control > Setting min. desired value**.
2. Enter desired value.
3. Press the **Accept** button to save the modified parameter.

**9.3.1.1.2 Active power-dependent adjustment of desired voltage value**

The TAPCON® Dynamic Setpoint Control (TDSC) function is used to adapt the desired voltage value depending on the measured active power. This allows you to compensate for a voltage drop during increased load or a voltage increase due to a decentralized feed-in.

Depending on whether positive or negative active power is measured, the desired value calculation is based on 2 linear equations (see example in diagram below).

Parameter	Function	Settings (see diagram below)
$U_{max}$ : Maximum desired value	Maximum set desired value is activated when $P_{max}$ is exceeded.	403.0 V
$U_{min}$ : Minimum desired value	Minimum set desired value is activated when value falls below $P_{min}$ .	399.0 V
$U_0$ : Desired value at 0 active power	Set desired value is activated when measured active power is 0 MW.	400.00 V
$P_{max}$ : Active power at max. desired value	Set maximum active power value above which the power-dependent desired value is to attain the maximum value $U_{max}$ .	20.0 MW
$P_{min}$ : Active power at min. desired value	Set minimum active power value below which the power-dependent desired value is to attain the minimum value $U_{min}$ .	-20.0 MW

Table 39: Parameters to be set for active power-dependent adjustment of desired voltage value

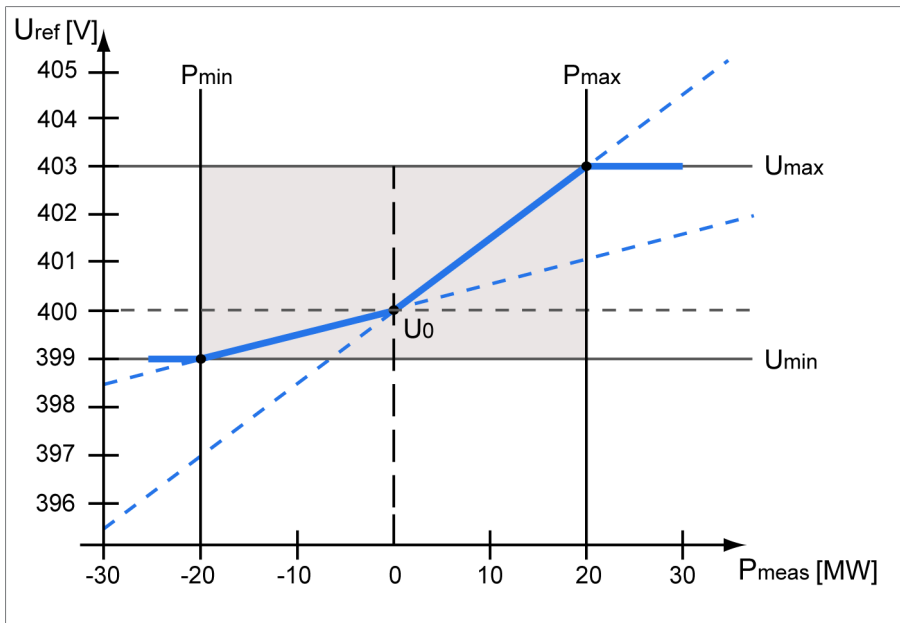

Figure 54: Active power-dependent adjustment of desired voltage value

$U_{ref}$	Desired value	$U_{min}$	Minimum desired value
$P_{meas}$	Measured active power	$U_{max}$	Maximum desired value
$P_{min}$	Active power at minimum desired value	$U_0$	Set desired value when measured active power = 0
$P_{max}$	Active power at maximum desired value		

**Response to active power  $P_{max}$  being exceeded**

If the measured active power  $P_{meas}$  exceeds the set parameter  $P_{max}$ , the value  $U_{max}$  is adopted as the desired value.

$$U_{ref} = U_{max}$$

**Response to value falling below active power  $P_{min}$**

If the measured active power  $P_{meas}$  falls below the set parameter  $P_{min}$ , the value  $U_{min}$  is adopted as the desired value.

$$U_{ref} = U_{min}$$

**Response to a measured active power  $P_{meas} = 0$  MW:**

If the measured active power  $P_{meas} = 0$ , the set parameter  $U_0$  is adopted.

$$U_{ref} = U_0$$

**Linear dependency with negative active power:**

If the measured active power  $P_{\min} \leq P_{\text{meas}} \leq 0$ , the desired value is calculated using the following equation:

$$U_{\text{ref}} = \frac{U_0 - U_{\min}}{0 - P_{\min}} \times P_{\text{meas}} + U_0$$

**Linear dependency with positive active power:**

If the measured active power  $0 \leq P_{\text{meas}} \leq P_{\max}$ , the desired value is calculated using the following equation:

$$U_{\text{ref}} = \frac{U_{\max} - U_0}{P_{\max}} \times P_{\text{meas}} + U_0$$

To activate the active power-dependent adjustment of the desired voltage value, you need to set the following parameters:

**Activating TDSC**

The TDSC function is only active when the device can calculate the active power (correct current measurement and voltage measurement) and the required parameters are set. If this is not the case, voltage regulation is in accordance with the set desired value. You can activate or deactivate the power-dependent adjustment of the desired voltage value as follows:

- Parameter
- Digital inputs *TDSC on* and *TDSC off*
- Control system command

**Activating/deactivating TDSC**

1. Go to **Settings > Parameters > Control > Activate TDSC**.
2. Select the desired option.
3. Press the **Accept** button to save the modified parameter.

**TDSC Umax/Umin**

You can use these parameters to set the maximum and minimum desired value. The maximum or minimum desired value is activated when the measured active power reaches the set minimum or maximum active power.

1. Go to **Settings > Parameters > Control > TDSC Umax/Umin**.
2. Enter maximum/minimum desired value.
3. Press the **Accept** button to save the modified parameter.



### TDSC U0

You can use this parameter to set the desired value which is to be used when the measured active power is 0.

1. Go to **Settings > Parameters > Control > TDSC U0**.
2. Enter desired value at active power 0.
3. Press the **Accept** button to save the modified parameter.

### TDSC Pmax/Pmin

You can use these parameters to set the maximum and minimum active power value at which the maximum and minimum active power-dependent desired value is to be used for regulation.

1. Go to **Settings > Parameters > Control > TDSC Pmax/Pmin**.
2. Enter active power for maximum/minimum desired value.
3. Press the **Accept** button to save the modified parameter.

### Bandwidth

You can use this parameter to set the maximum permissible deviation of the measured voltage  $U_{\text{actual}}$  from the desired value  $U_{\text{desired}}$ .



In order to set the correct value, the transformer step voltage and nominal voltage must be known. Note that a large bandwidth will result in a large control deviation.

The bandwidth must always be greater than the following value:

$$|\pm B| \geq 0,6 \times \frac{U_{n-1} - U_n}{U_N} \times 100\%$$

$U_{n-1}$	Step voltage of tap position n-1
$U_n$	Step voltage of tap position n
$U_N$	Nominal voltage



The following transformer values are used to determine the minimum bandwidth:

Nominal voltage  $U_N = 11000 \text{ V}$

Step voltage in tap position 4  $U_{\text{Step4}} = 11275 \text{ V}$

Step voltage in tap position 5  $U_{\text{Step5}} = 11000 \text{ V}$

$$[\pm B\%] \geq 0,6 \cdot \frac{U_{\text{Step4}} - U_{\text{Step5}}}{U_{\text{nom}}} \cdot 100\%$$

$$[\pm B\%] \geq 0,6 \cdot \frac{11275 \text{ V} - 11000 \text{ V}}{11000 \text{ V}} \cdot 100\%$$

$$[\pm B\%] \geq 1,5\%$$

### Delay time T1

Delay time T1 delays the issuing of a tap-change command for a defined period. This prevents unnecessary tap-change operations if the tolerance bandwidth is exited briefly.

### Response to delay time T1

If the control variable **5** is within the set bandwidth **6**, no control commands are issued to the motor drive unit for the tap change. Control commands will also not be issued to the motor-drive unit if the control variable returns to the bandwidth **4** within the set delay time T1 **6**. However, if the control variable deviates from the set bandwidth for a long period **C**, a tap-



change command **D** is issued after expiration of the set delay time T1. The on-load tap-changer carries out a tap-change in a raise or lower direction to return to the tolerance bandwidth.

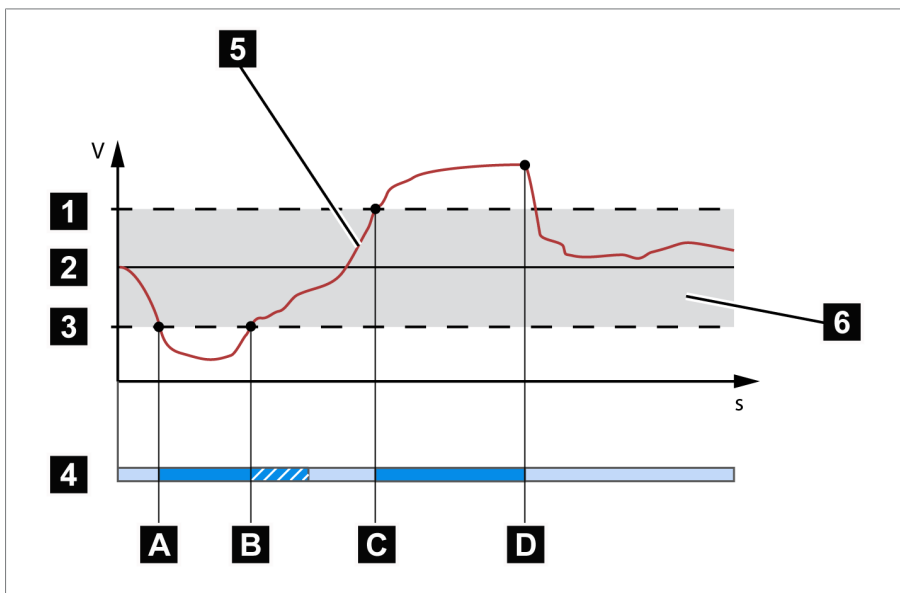

Figure 55: Behavior of the control function with delay time T1

1 Upper limit of bandwidth	4 Set delay time T1
2 Desired value	5 Control variable measured value
3 Lower limit of bandwidth	6 Bandwidth range
A Control variable is outside of the bandwidth. Delay time T1 starts.	B Control variable returned to within the bandwidth before delay time T1 has expired.
C Control variable is outside of the bandwidth. Delay time T1 starts.	D Control variable is still outside the bandwidth after delay time T1 has expired. Tap-change operation is initiated.

### 9.3.2 Parallel operation

Parallel transformer operation is used to increase the throughput capacity or short-circuit capacity at one location. The device provides you with specific functions for regulating transformers.

#### Conditions for parallel operation

Compliance with the following general conditions is required for operating transformers in parallel:

- Identical rated voltages
- Transformer power ratio (< 3 : 1)
- Maximum deviation of short-circuit voltages ( $U_k$ ) for transformers connected in parallel < 10%

- The same number of switching groups
- For parallel operation with CAN communication: Current transformers with the same connection values must be used for all devices operating in parallel

### 9.3.2.1 Parallel operation methods

You can undertake parallel operation with various parallel operation methods.

#### 9.3.2.1.1 Tap synchronization

With the **tap synchronization** parallel operation method, one voltage regulator works as the master and all others as followers.

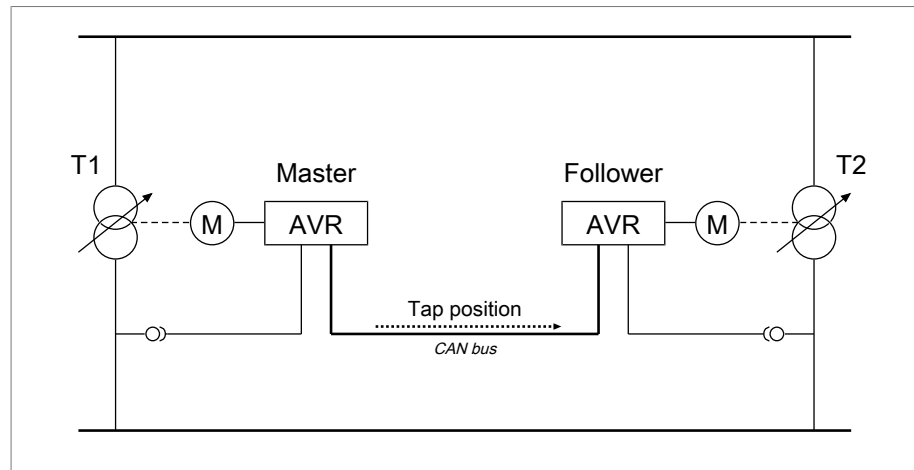

Figure 56: Tap synchronization

The master handles voltage regulation and transmits its current tap positions to all followers via the CAN bus. The followers compare the tap position received with their own tap position. If the tap position is not the same, the followers switch to the tap position received from the master. This ensures that the transformers operating in parallel are always in the same tap position.

You can set whether the master transmits the change in tap position to the followers before or after its own tap-change operation. The devices then either change position sequentially (first the master, then the followers) or in synch (master and followers at the same time).

If there is a tap difference between the master and followers, the master refrains from issuing any control commands to the motor-drive unit until all of the followers have reached the same tap position. If the tap difference persists for longer than the set delay time for parallel operation error messages, the master triggers the *Step difference to follower* event.

You can explicitly designate the voltage regulators as master and followers, or set automatic designation using the CAN bus address.

For the tap synchronization parallel operation method, you have to set the following parameters:

Parameter	Auto	Master	Follower
Activating parallel operation		Yes	
Parallel operation method	Auto. tap sync.	Master	Follower
CAN bus address		Yes	
Circulating reactive current blocking limit	Optional, if master/follower current blocking is active		
Master/follower current blocking		Yes	
Master/follower switching characteristics		Yes	
Maximum tap difference	Yes (if follower)	No	Yes
Error if no communication present		Yes	
Behavior if no communication present		Yes	
Parallel operation error delay time		Yes	

Table 40: Parameter

### 9.3.2.1.2 Circulating reactive current minimization with CAN bus communication

With the **circulating reactive current** parallel operation method, parallel operation is carried out using the circulating reactive current minimization method.

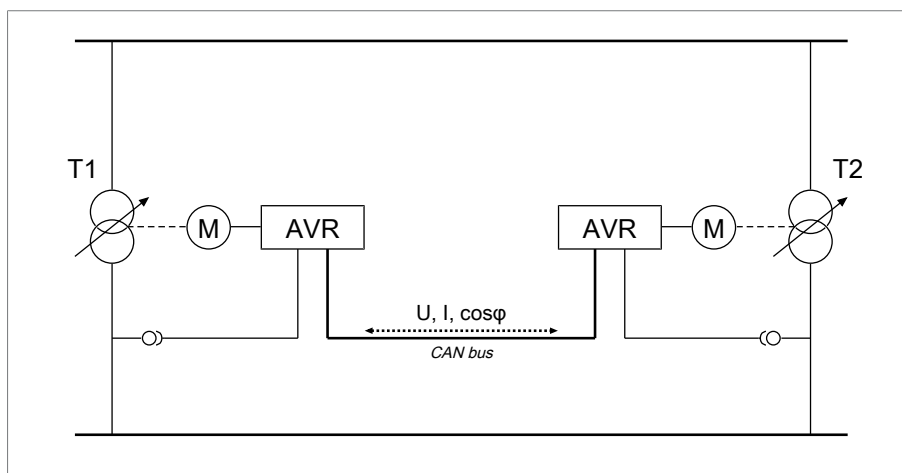

Figure 57: Circulating reactive current minimization with CAN bus communication

The circulating reactive current is calculated from the transformer currents and their phase angles. The voltage regulators in the parallel operation group share this information via CAN bus. An extra control deviation propor-



tional to circulating reactive current is added to the independently regulating voltage regulators as a correction for the control deviation determined on the basis of the measurement voltage. You can use the circulating reactive current sensitivity parameter to decrease or increase this extra control deviation.

The circulating reactive current method is suited to transformers connected in parallel with a similar nominal output and short-circuit voltage  $U_K$  and to vector groups with the same and different step voltages. This does not require any information about the tap position.

Note that the following prerequisites must be met for the "circulating reactive current minimization" parallel operation method:

- You have to use current transformers with the same rated values for all transformers in parallel operation.
- If you wish to operate in parallel operation with existing devices, you have to activate the Retrofit TAPCON® 2xx parameter.

For the circulating reactive current minimization parallel operation method with CAN communication, you have to set the following parameters:

- Activate parallel operation
- Parallel operation method: Circulating reactive current
- CAN bus address
- Circulating reactive current sensitivity
- Circul. reactive current blocking limit
- Error if no communication present
- Behavior if no communication present
- Parallel operation error delay time

### 9.3.2.1.3 Circulating reactive current minimization without CAN bus communication

With this method, you can operate several voltage regulators without a communication connection (CAN bus) in parallel with circulating reactive current minimization.

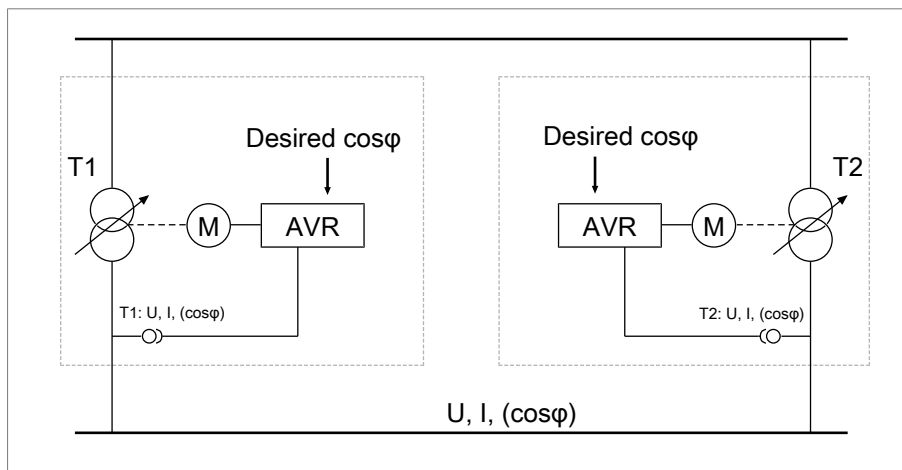

Figure 58: Circulating reactive current minimization without CAN bus communication

The circulating reactive current is calculated using the desired power factor parameter, the desired load stress type parameter, and the measured transformer current. An extra control deviation proportional to circulating reactive current is added to the independently regulating voltage regulators as a correction for the control deviation determined on the basis of the measurement voltage. This extra control deviation depends on how much the measured power factor deviates from the desired power factor.

To use the power factor method, you need to know the conditions of your network in order to correctly set the device parameters.

The power factor method is suited to transformers connected in parallel with a similar nominal output and short-circuit voltage  $U_K$  and to vector groups with the same and different step voltages. This does not require any information about the tap position.

For the circulating reactive current minimization parallel operation method without CAN communication, you have to set the following parameters:

- Activating parallel operation
- Parallel operation method: Power factor
- Circulating reactive current sensitivity
- Circulating reactive current blocking limit
- Desired power factor
- Desired load stress type
- Parallel operation error delay time



Note that the parameters "Error if no communication" and "Behavior if no communication" have no function in the circulating reactive current minimization without CAN communication parallel operation method.

### 9.3.2.2 Configuring parallel operation

In the **Parallel operation** menu item, you can set the parameters needed for parallel transformer operation.

1. Go to **Settings > Parameters > Grid > Parallel operation > .**
2. Select the desired parameter.
3. Set the desired parameter.
4. Press the **Accept** button to save the modified parameter.

#### 9.3.2.2.1 Activating parallel operation

You can use this parameter to activate or deactivate parallel operation.

#### 9.3.2.2.2 Setting parallel operation method

You can use this parameter to set the parallel operation method. You can select the following options:



Only change the parallel operation method when the on-load tap-changers are not performing tap-change operations.

Option	Description
Master	The device is designated as the master. Tap synchronization parallel operation method
Follower	The device is designated as the follower.
Auto. tap sync.	Automatic assignment of master or follower. If a master is not detected, the device with the lowest CAN bus address is automatically designated as the master. All other devices are designated as followers.
Circulating reactive current	Circulating reactive current minimization with CAN bus communication parallel operation method
Power factor	Circulating reactive current minimization without CAN bus communication parallel operation method

Table 41: Setting parallel operation method



### 9.3.2.2.3 Assigning a CAN bus address

You can use this parameter to assign a CAN bus address to the device. So that all devices can communicate using the CAN bus, each device requires a unique identifier. If the value is set to 0, then no communication takes place.

### 9.3.2.2.4 Setting circulating reactive current sensitivity

You can use this parameter to set the influence of circulating reactive current on how the control deviation is calculated. The higher the set value, the greater the calculated control deviation as a result of circulating reactive current.

To determine the ideal circulating reactive current sensitivity, note the relevant section in the Commissioning chapter.

### 9.3.2.2.5 Setting the circulating reactive current blocking limit

You can use this parameter to set the limit value for the maximum permissible circulating reactive current. This value is based on the rated current of the current transformer. If, during parallel operation, the circulating reactive current exceeds the set limit value, the device triggers the *Circulating reactive current blocking limit exceeded* event. All devices operating in the parallel operation group are blocked.

#### Desired power factor

You can use this parameter to set the power factor, which the transformer has under normal operating conditions. If the measured power factor deviates from the desired one, the device calculates a correction which is added to the control deviation.



Enter a desired power factor other than 0. If you enter a desired power factor of 0, the device is not able to calculate the voltage correction.

#### Desired load stress type

You can use this parameter to set the load stress type, which the transformer has under normal operating conditions.

You can determine the load stress type using the phase angle difference between voltage and current. You calculate the phase angle difference as follows:

$$\varphi_{UI} = \varphi_U - \varphi_I$$

Figure 59: Calculation of phase angle difference

$\varphi_{UI}$	Phase angle difference between voltage and current
$\varphi_U$	Phase angle of voltage
$\varphi_I$	Phase angle of current

Depending on the calculated phase angle difference, you have to select the following option:

- $\varphi_{UI} > 0$ : Inductive
- $\varphi_{UI} < 0$ : Capacitive

#### 9.3.2.2.6 Setting master/follower current blocking

You can use this parameter to activate the circulating reactive current blocking limit for the tap synchronization parallel operation method. The device thereby calculates and monitors the circulating reactive current in the same manner as the parallel operation method for circulating reactive current minimization, and provides you with the safety function of circulating reactive current blocking. The Circulating reactive current blocking parameter is used to set the limit value.

#### 9.3.2.2.7 Setting master/follower switching characteristics

You can use this parameter to set the switching characteristics for the tap synchronization parallel operation method. You can select the following options:

- **Sequentially:** When a tap-change operation takes place, the master communicates its new tap position to the followers via the CAN bus as soon as the master has completed its tap-change operation. The tap-change operations of the master and followers thereby take place one after another (sequentially).
- **In sync:** When a tap-change operation takes place, the master communicates its new tap position to the followers via the CAN bus as the master starts its tap-change operation. The tap-change operations of the master and followers thereby take place at almost the same time (in synch).

#### 9.3.2.2.8 Setting the maximum tap difference

You can use this parameter to set the maximum permissible tap difference between followers and master on the follower.



If the tap difference is greater than the set maximum tap difference to the master, the follower blocks and no longer attempts to attain the master's tap position. After the set delay time for parallel operation error messages has elapsed, the follower issues the *Permitted tap difference to master exceeded* message.

**9.3.2.2.9 Setting error if no communication present**

You can use this parameter to set whether it is an error if the device does not receive any messages via the CAN bus or if there are no other CAN bus participants in the same parallel operation group.

**9.3.2.2.10 Setting behavior if no communication present**

You can use this parameter to set how the voltage regulator behaves if communication via the CAN bus is not possible.



The setting for this parameter is only effective if you have selected the **Error** option for the **Error if no communication present** parameter.

You can select the following options:

Option	Description
Independent regulation	The device switches from parallel operation to normal automatic voltage regulation
Auto blocking	Automatic voltage regulation is blocked.
cosφ interpolation	Continuation of parallel operation with interpolated values (only possible with circulating reactive current parallel operation method)
Power factor	Circulating reactive current minimization without CAN bus communication parallel operation method

Table 42: Behavior if no communication present

**9.3.2.2.11 Setting delay time for parallel operation error messages**

You can use this parameter to set the delay time for a parallel operation error message so that brief fault messages are not received if the motor-drive units involved in the parallel operation have different runtimes.

### 9.3.2.3 Parallel operation

In the parallel operation menu, you can display information about the devices that are connected by CAN bus.



	Description
	Parallel operation status: <ul style="list-style-type: none"> <li>▪ - = Independent mode</li> <li>▪ ✓ = Parallel operation is active</li> <li>▪  = Parallel operation error</li> </ul>
CAN	CAN bus address
Grp.	Parallel operation group
Method	Active parallel operation method
Position	Current tap position
U	Voltage
I <sub>p</sub>	Active current
I <sub>q</sub>	Reactive current
Block.	Blocking: <ul style="list-style-type: none"> <li>▪ Gray: Parallel operation not blocked</li> <li>▪ Red: Parallel operation blocked</li> </ul>

Table 43: Information about parallel operation

► Go to **Information > Parallel operation**.

### 9.3.3 U bandwidth monitoring

The following limit values are monitored via bandwidth monitoring. The set bandwidth [► Page 107] (upper/lower) of the voltage regulation is used for this purpose.

**Behavior** If the measured value is higher than the upper limit or lower than the lower limit, the device triggers the *Upper bandwidth limit value / Lower bandwidth limit value* message.

The "Function monitoring" function is used to detect long periods when values are above or below the bandwidth. Long periods when values are above or below the bandwidth indicate a problem with the device function because the device is not able to correct the control deviation.

If the value is above or below the set bandwidth [► Page 107], the *Function monitoring* event is displayed after the set delay time for function monitoring has elapsed. The event is automatically acknowledged as soon as the measured value is back within the set bandwidth.

The following parameters are available for setting function monitoring:

- Function monitoring
- Hysteresis
- Delay time



1. Go to **Settings > Parameters > On-load tap-changer regulator > U bandwidth monitoring**.
2. Select the desired parameter.
3. Set the desired parameter.
4. Press the **Accept** button to save the modified parameter.

You can set additional parameters for each limit value:

### Function monitoring

You can use this parameter to activate function monitoring. You can select the following options:

Setting	Behavior
Off	Function monitoring is deactivated.
Only Auto	Function monitoring is only active in AVR AUTO operating mode.
Auto and Manual	Function monitoring is active in AVR AUTO and AVR MANUAL operating modes

Table 44: Activate function monitoring

### Hysteresis

You can use this parameter to set the hysteresis. You can use this to avoid the unnecessary generation of messages if the measured value fluctuates around a threshold value.

### Delay time

You can use this parameter to set the delay time in order to delay the issuing of the event message.



## 9.4 On-load tap-changer

### 9.4.1 Tap position monitoring

You can set the limit value parameter for tap position monitoring:

1. Go to **Settings > Parameters > On-load tap-changer > Tap position monitoring**.
2. Select the desired parameter.
3. Set the desired parameter.
4. Press the **Accept** button to save the modified parameter.

#### Delay time

You can use this parameter to set the delay time in order to delay the issuing of the event message.

#### Behavior limit value

You can use this parameter to set the behavior of the device when the event message is issued. You can select the following options:

Setting	Behavior
Off	Tap position monitoring is disabled.
Auto blocking position+	The automatic control does not perform a tap-change operation in the direction of a higher tap position (position+). You can still perform a tap-change operation in the direction of a higher tap position (position+) in manual mode.
Auto blocking position-	The automatic control does not perform a tap-change operation in the direction of a lower tap position (position-). You can still perform a tap-change operation in the direction of a lower tap position (position-) in manual mode.
Auto/manual blocking position+	The automatic control does not perform a tap-change operation in the direction of a higher tap position (position+). You cannot perform a tap-change operation in the direction of a higher tap position (position+) in manual mode.
Auto/manual blocking position-	The automatic control does not perform a tap-change operation in the direction of a lower tap position (position-). You cannot perform a tap-change operation in the direction of a lower tap position (position-) in manual mode.

#### Operations counter

The device's operations counter is automatically increased with every tap-change operation. You can use this parameter to set the number of tap-change operations, such as for a comparison with the operations counter of the motor-drive unit.



## 9.4.2 Tap position capture method

The current tap position of the on-load tap-changer is transmitted from the motor-drive unit to the device. You can use this parameter to select the type of tap position capture.



In order to ensure proper function of the tap position capture, make sure that the inputs of the corresponding tap position capture method are activated and correctly wired.

1. Go to **Settings > Parameters > On-load tap-changer > Tap position monitoring > Tap position capture method**.
2. Select the desired tap position method.
3. Press the **Accept** button to save the modified parameter.

The tap position is transmitted in one of the following ways:

### 9.4.2.1 Digital tap position capture

The tap position can be transmitted as a digital signal from the motor-drive unit to the device. The following variants are available:

- BCD
- Dual code
- Gray code
- N/O contact series

### 9.4.2.2 Analog tap position capture

The tap position can be transmitted as an analog signal from the motor-drive unit to the device. The following variants are available:

#### 9.4.2.2.1 Injected current (0/4...20 mA)

For the analog tap position capture, you must set which tap positions correspond to the minimum analog signal and maximum analog signal.

##### Pos. at max. analog signal

You can use this parameter to set the tap position of the on-load tap-changer corresponding to the maximum analog signal (e.g. 20 mA for 4...20 mA signal).

1. Go to **Settings > Analog tap position capture > Pos. at max. analog signal**.
2. Set the tap position.
3. Press the **Accept** button to save the modified parameter.

### Pos. at min. analog signal

You can use this parameter to set the tap position of the on-load tap-changer corresponding to the minimum analog signal (e.g. 4 mA for 4...20 mA signal).

1. Go to **Settings > Analog tap position capture > Pos. at min. analog signal**.
2. Set the tap position.
3. Press the **Accept** button to save the modified parameter.

#### 9.4.2.2.2 Resistor contact series



Carry out the calibration at an ambient temperature that corresponds to normal operating conditions. This allows you to reduce measurement errors due to temperature fluctuations.

To capture the tap positions via resistor contact series, you need to perform a calibration. In order to do this, you have to set the on-load tap-changer's tap positions corresponding to the maximum and minimum analog signal. Then you have to carry out on-load tap-change operations across the entire tap position range. The entire calibration process is performed using wizards.

1. Go to **Settings > Calibrate hardware > Calibrate RCS**.
2. Select the **Pos. at max. analog signal** parameter.
3. Set the tap position.
4. Press the **Accept** button to save the modified parameter.
5. Select the **Pos. at min. analog signal** parameter.
6. Set the tap position.
7. Press the **Accept** button to save the modified parameter.
8. Click on the **Start** button.
  - ⇒ The calibration wizard is started.
9. Press the **Next** button.
10. Step 1: Manually switch on-load tap-changer to the highest tap position.
11. Press the **Next** button.
  - ⇒ Step 2: The device calibrates the current output and once complete moves on to step 3.
12. Step 3: Manually switch the on-load tap-changer to the lowest tap position.
  - ⇒ Step 4: The device determines the offset and once complete moves on to step 5.
13. Step 5: Press the **Next** button to complete calibration.
  - ⇒ Calibration of tap position capture using the resistor contact series has been performed successfully.



### 9.4.3 Target-tap-position operation

When target-tap-position operation is activated, the device automatically switches to this target tap position.

1. Go to **Settings > Parameters > On-load tap-changer > Move to the defined target tap position**.
2. Enter the target tap position.
3. Press the **Accept** button to save the modified parameter.

#### Target tap position

You can use this parameter to define a target tap position.

### 9.4.4 OLTC data

In this menu, you can set parameters for the on-load tap-changer (OLTC).

1. Go to **Settings > Parameters > On-load tap-changer > OLTC data**.
2. Select the desired parameter.
3. Set the desired parameter.
4. Press the **Accept** button to save the modified parameter.

#### 9.4.4.1 Tap-change operations waiting time



This parameter can only be set by the Maschinenfabrik Reinhausen GmbH Technical Service department.

You can set the waiting time between 2 consecutive tap-change operations with this parameter. This function is used to prevent the on-load tap-changer from overheating due to frequent tap-change operations.

### 9.4.5 Information about the on-load tap-changer

Under "OLTC" you can display information about the on-load tap-changer:

- Current tap position
- Total tap-change operations (operations counter)
- ▶ Go to **Information > On-load tap-changer > OLTC**.

## 9.5 Motor-drive unit and control cabinet

### 9.5.1 Control of the motor-drive unit



#### 9.5.1.1 Setting the switching pulse for controlling the motor-drive unit

You can use the parameters Switching pulse type, Switching pulse time and Switching pulse pause to adapt the device switching pulse to the requirements of the motor-drive unit controller.

1. Go to **Settings > Parameters > Motor and control cabinet > Motor control**.
2. Select the desired parameter.
3. Set the parameter.
4. Press the **Accept** button to save the modified parameter.

#### Switching pulse type

You can use this parameter to toggle the switching pulse between a continuous pulse or a time-controlled switching pulse.

**Continuous pulse** Selecting the "Continuous pulse" option causes the device to issue the switching pulse in AVR Auto operating mode until the measured value is back within the bandwidth. In AVR Manual operating mode, the device issues the switching pulse for as long as you press the  or  key.

If the device is operated as a follower in parallel operation in this case, then the voltage regulator will issue the switching pulse until one of the following requirements has been met:

- The set motor runtime has been reached
- The *Motor running* signal switches from state 1 to 0
- The tap position required by the master has been reached

A pause is enforced after every switching pulse before another switching pulse is issued.

**Time-controlled switching pulse** Selecting the "Time-controlled switching pulse" option causes the device to issue the switching pulse for a set duration. A pause **1** is enforced after every switching pulse **2** before another switching pulse is issued.



If you use a motor-drive unit from Maschinenfabrik Reinhausen GmbH, you need to select the "Time-controlled switching pulse" option.

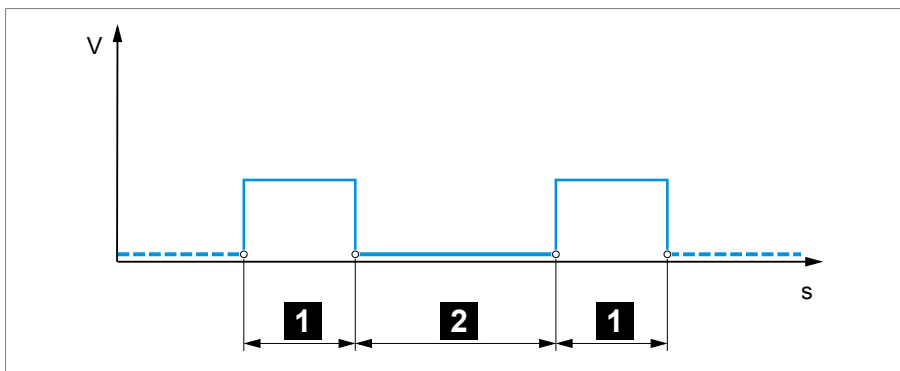

Figure 60: Switching pulse time and switching pulse pause

1 Switching pulse time

2 Switching pulse pause

### Switching pulse time

You can use this parameter to set the maximum duration of the switching pulse. The switching pulse resets after the switching pulse time has elapsed or if the device receives the *Motor running* signal beforehand or the tap position is changed.

### Switching pulse pause

You can use this parameter to set the switching pulse pause between 2 switching pulses. The device can only issue another switching pulse once the switching pulse pause has elapsed.

#### 9.5.1.2 Setting motor runtime monitoring

The motor-drive unit's runtime can be monitored by the device. This function is used to identify motor-drive unit malfunctions during the tap-change operation and to trigger any actions needed.

**Behavior** The motor-drive unit issues the *Motor-drive unit running* signal during the tap-change operation. This signal is present until the tap-change operation is complete. The device compares the duration of this signal with the set motor runtime. If the set motor runtime is exceeded, the device triggers the following actions:

1. *Motor runtime exceeded* event.
2. Pulse signal via *Trigger motor protective switch* output relay



Note that motor-drive units with pass-through positions or motor-drive units without stepped switching behavior will run for longer under certain circumstances. Set a longer motor runtime for such units.

1. Go to **Settings > Parameters > Motor and control cabinet > Motor control**.
2. Select the desired parameter.



3. Set the parameter.
4. Press the **Accept** button to save the modified parameter.

**Motor runtime**

You can use this parameter to set the motor runtime.

**Motor runtime monitoring**

You can use this parameter to activate or deactivate motor runtime monitoring.

**9.5.1.3 Setting the switching direction**

You can set the switching direction of the motor-drive unit.

1. Go to **Settings > Parameters > Motor and control cabinet > Motor control**.
2. Select the desired parameter.
3. Set the parameter.
4. Press the **Accept** button to save the modified parameter.

**U switching direction**

You can use this parameter to set the switching direction for voltage regulation. You can use this to adjust the behavior of the device based on how your on-load tap-changer and motor-drive unit are configured. You can select the following options:

Setting	Meaning
Standard	The device issues a signal via the <i>Raise</i> output to increase the voltage. The device issues a signal via the <i>Lower</i> output to reduce the voltage.
Swapped	The device issues a signal via the <i>Lower</i> output to increase the voltage. The device issues a signal via the <i>Raise</i> output to reduce the voltage.

Table 45: Behavior



## 10 Maintenance and care

### 10.1 Cleaning the device

You can clean the device with a dry cloth.

### 10.2 Updating application software

#### NOTICE

#### Damage to the device due to incompatible wiring and configuration.

If the configuration of the device inputs and outputs is changed as a result of updating the application software, the device can become damaged due to incompatible wiring.

- ▶ Before updating the device application software, wire it according to the connection diagram provided with the device.

If you want to update the application software using web-based visualization on a PC, proceed as follows:

1. Copy the application software to the PC [▶ Section 10.2.1, Page 127].
2. Establish a connection to the visualization [▶ Section 10.2.2, Page 128].
3. Update the application software [▶ Section 10.2.3, Page 129].

#### 10.2.1 Copy the application software to the PC

You can download the latest version of the application software from the Maschinenfabrik Reinhausen GmbH customer portal. To do so, proceed as follows:

1. Call up the website [www.reinhausen.com](http://www.reinhausen.com).
2. Press the **Customer Portal** button.
3. Login with your login data or register.
4. In the **Transformer** section at the **My Devices** tile, press the **Open** button.
5. If the desired device does not appear in the list, press the **Add device** button and enter the device data (serial number, name, location, etc.).
6. Select the desired device in the list.
7. Select the device in the **Firmware** tab and select the **Create firmware** button in the **MR Versions** entry for the desired version. If the firmware cannot be generated automatically, you will see the **Request** button, which you can use to send a request to Maschinenfabrik Reinhausen GmbH.
  - ⇒ The firmware is generated. You will receive an email when the firmware is available for download.
8. Press the **Download** button to save the firmware to the PC.
9. Press the ... button to display the hash value for verifying the download.

- Calculate the hash value of the downloaded zip file on your PC and compare it with the hash value displayed in the customer portal. If both values are identical, the file was downloaded correctly.



Depending on your operating system, you can calculate the hash value of the file in different ways. If you run your PC with Windows 10, you can calculate the hash value in the command line with the following command:

```
certutil -hashfile <filename>.zip sha256
```

- Unzip the zip file on your PC.
  - ⇒ The application software has been downloaded correctly.

### 10.2.2 Establishing connection to visualization

A connection to the visualization can be established using two interfaces:

- Front interface (for local access)
- Optional: Interface X3 on the rear of the device (for access via remote display, control center etc.)

#### System requirements

To access the web-based visualization, you need a PC with an HTML5-capable browser. The display is optimized for the following browsers:

- Microsoft® Internet Explorer 11
- Google Chrome™

#### Establishing a connection via front interface

- Remove the interface cover on the front of the device.
- Connect the COM-X2 to the CPU-X3 using the supplied patch cable.

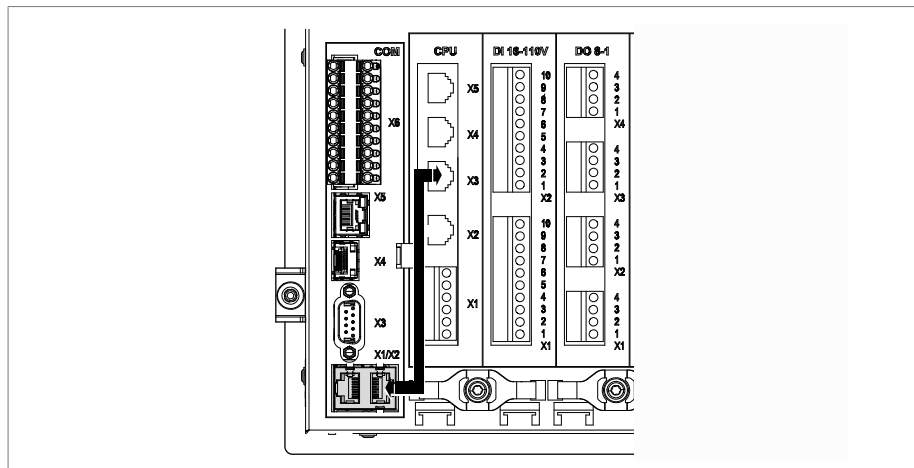

Figure 61: Patch cable on the rear

3. Connect the PC and the device via the front interface using an Ethernet cable (RJ45 plug).

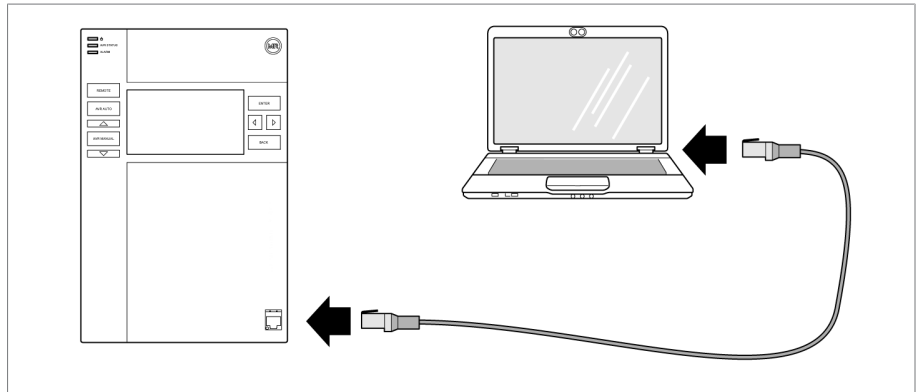

Figure 62: Establishing a connection via the front interface

4. Enter the visualization's IP address `http://192.168.165.1`, or if SSL encryption is active, enter `https://192.168.165.1` in the browser on the PC.

⇒ The visualization is accessed.

#### Establishing a connection via the rear CPU-X3 interface

1. Connect the PC and device via the rear CPU-X3 interface using the pre-assembled patch cable.
2. Go to **Communication** on the device to display the device's IP address.
3. Assign a unique IP address to the PC in the same subnet as the device (e.g. `192.0.1.100`).
4. Enter the visualization's IP address (e.g. `http://192.0.1.230`; if SSL encryption is active enter `https://192.0.1.230`) in the browser on the PC.

⇒ The visualization is accessed.

### 10.2.3 Updating application software

#### NOTICE

#### Damage to the file system!

The file system can become damaged due to an incorrect data transmission process. A damaged file system can lead to the device no longer being functional.

- ▶ Do not disconnect the device from the power supply during the import.

When in delivery status, you can log in as the administrator as follows:

- User name: `admin`
- Password: `admin`



To load the application software, proceed as follows:

1. Press the **LOGIN** button and log in as a user with a parameter configurator or administrator user role.
2. Go to **Information > Software** and take note of the application software version.
3. Go to **Settings > Export > System image** to export a backup copy of the current system.
4. Select the option **With history** and press the **Start export** button to start the export.
5. Go to **Settings > Import**.
6. Press the **Browse** button, select the application software (rhp file) to be imported and then press the **Start upload** button.  
⇒ The file is checked.
7. Select the options **Retain historical data**, **Retain user settings** and **Retain device settings**.
8. Press the **Start update** button to start the import.  
⇒ The application software is updated.
9. Press the **OK** button to restart the device following a successful update.
10. Go to **Information > Software** and compare the application software version with the version noted down. The version number must be higher.



## 11 Fault elimination

This chapter describes how to rectify simple operating faults.

### 11.1 General faults

Characteristics/details	Cause	Remedy
No function	No power supply.	Check the power supply.
<ul style="list-style-type: none"> <li>▪ <i>Power supply</i> LED does not light up</li> </ul>	Fuse tripped.	Contact Maschinenfabrik Reinhausen GmbH.
No function	Configuration error	Contact Maschinenfabrik Reinhausen GmbH.
<ul style="list-style-type: none"> <li>▪ <i>AVR STATUS</i> LED does not light up</li> </ul>		
Relay chatter	High EMC load.	Use shielded cables or external filters.
	Poor grounding.	Check the functional ground.

Table 46: General faults

### 11.2 No regulation in AUTO mode

Characteristics/details	Cause	Remedy
Device control commands have no effect.	Local/Remote switch in motor-drive unit switched to LOCAL.	Check operating mode. Correct if necessary.
	No connection	Check wiring as per connection diagram.
Automatic voltage regulation is blocked. <ul style="list-style-type: none"> <li>▪ <i>ALARM</i> LED lights up in accordance with event configuration and a corresponding event is active.</li> </ul>	Limit value with auto blocking or auto/manual blocking behavior has been exceeded.	Check parameters. Correct if necessary.
	The switching direction monitoring has recorded a malfunction and triggered the associated event.	Check cause of event and then acknowledge event.
	The motor protective switch has triggered. Motor protective switch event active.	Check what caused the motor protective switch to trigger and engage motor protective switch if necessary.
Automatic voltage regulation is blocked.	Signal at "Block automatic voltage regulation" input.	Check signal source.
	Target-tap-position operation active	Check configuration of target-tap-position operation function. If necessary, remedy cause.
	"Blocking" function is linked to a digital input or control system message.	Check signal source or control system. If necessary, reset.
Automatic voltage regulation is blocked. <ul style="list-style-type: none"> <li>▪ Measured voltage too low (&lt; 30 V)</li> </ul>	Voltage measurement incorrect	Check voltage measurement.
Bandwidth set too high	-	Determine the recommended bandwidth.



Characteristics/details	Cause	Remedy
Parallel operation active.	Device is follower in parallel operation.	No error. If necessary, deactivate parallel operation.
CAN bus communication failure	"Auto blocking" behavior is set.	Check configuration.

Table 47: No regulation in AUTO mode

### 11.3 Human-machine interface

Characteristics/details	Cause	Remedy
Display ▪ No display.	Power supply interrupted.	Check the power supply.
	Fuse faulty.	Contact Maschinenfabrik Reinhausen.
Connection cannot be established with visualization	Connection cable defective.	Check connection cable.
	SSL encryption active.	Accept SSL certificate in browser. Call up IP address using <code>https://</code> . Deactivate SSL encryption.
	PC not in same subnet as visualization.	Check the setting of IP addresses of the device and PC and correct if necessary.
Incorrect display of visualization in the web browser.	Access to the visualization using a web browser after a software update.	Delete the web browser's cache.

Table 48: Human-machine interface

### 11.4 Incorrect measured values

Characteristics/details	Cause	Remedy
Measured voltage ▪ No measured value available.	Connection has no contact in the plug terminal.	Check the wiring and plug terminal.
	Insulation trapped.	
	Wire is not inserted far enough.	
Measured voltage ▪ Measured value too low	Miniature circuit breaker has tripped.	Check the fuse.
	Voltage drop on the measuring line.	Check the measured voltage.
Measured voltage ▪ Measured value fluctuates	Possible sources of interference: ▪ Cables laid in parallel. ▪ Tap-change operations.	Check the measured voltage.
		Increase the distance from the source of interference.
		Install a filter if necessary.



Characteristics/details	Cause	Remedy
Measured current <ul style="list-style-type: none"> <li>No measured value</li> </ul>	Line to the current transformer interrupted.	Check wiring.
	Short-circuiting jumper in current transformer is not removed.	Remove the short-circuiting jumper.
Measured current <ul style="list-style-type: none"> <li>Measured value too high</li> <li>Measured value too low</li> </ul>	Current transformer not correctly parameterized.	Correct parameterization.

Table 49: Incorrect measured values

### 11.5 Parallel operation faults

Characteristics/details	Cause	Remedy
Problem with CAN bus. <ul style="list-style-type: none"> <li>Device not listed.</li> </ul>	Device incorrectly connected.	Check connections. Connect as shown in connection diagram.
	Devices have the same CAN bus addresses.	Set different CAN bus addresses.
	CAN bus address of device set to "0".	Set CAN bus address (anything but 0).
Problem with parallel operation.	Different parallel operation methods set for devices in the parallel operation group.	Check configuration.
Problem with master/follower parallel operation method.	More than 1 device is configured as master in the parallel operation group.	Check configuration.
	No device configured as master in the parallel operation group.	Check configuration.
	Invalid tap position of master or follower.	Check tap position. Check wiring. Connect as shown in connection diagram.
Problem with master/follower parallel operation method: <ul style="list-style-type: none"> <li>Master/follower switching characteristics is "in synch".</li> </ul>	Master and followers have different tap positions.	Check tap position capture or check why the tap-change operation has not been undertaken (e.g. mechanical defect), then perform one of the following steps: <ul style="list-style-type: none"> <li>Manually correct the master's tap position.</li> <li>Restart master.</li> <li>Set master/follower switching characteristics to "sequential".</li> <li>Change master device to follower and define a different device as the master.</li> </ul>
Problem with circulating reactive current minimization parallel operation method.	Circulating reactive current cannot be calculated.	Check wiring. Connect as shown in connection diagram.
	Circulating reactive current blocking limit exceeded.	Check configuration.

Table 50: Parallel operation faults



## 11.6 Tap position capture incorrect

Characteristics/details	Cause	Remedy
Position indicator incorrect. ▪ Leading sign incorrect.	Incorrect wiring.	Check wiring. Connect as shown in the connection diagram.
	Minimum value of the analog input signal not configured correctly.	Check parameters.
Position indicator incorrect. ▪ Display fluctuates.	Interference.	Shield the line.
		Increase the distance from the source of interference.
		Lay interference lines separately.
No position indicator. ▪ "- -" is displayed.	No measurement signal.	Connect the signal as shown in the connection diagram.
	No L- for digital input.	Check wiring. Connect as shown in the connection diagram.
Tap position capture over resistor contact series faulty.	Faulty calibration.	Calibrate the tap position capture over resistor contact series.
	Modified contact resistance values of the resistor contact series (e.g. due to weather or age).	Calibrate the tap position capture over resistor contact series.

Table 51: Tap position capture

## 11.7 Other faults

If you cannot resolve a problem, please contact Maschinenfabrik Reinhausen. Please have the following data ready:

- Serial number
  - Nameplate
  - Info screen
- Software version [► Section 9.1.12, Page 85]

Please provide answers to the following questions:

- Has the software been updated?
- Has there previously been a problem with this device?
- Have you previously contacted Maschinenfabrik Reinhausen about this issue? If yes, then who was the contact?



## 12 Disposal

Observe the national requirements applicable in the country of use.

## 13 Technical data

### 13.1 Display elements

Display	5" TFT colour display
LEDs	3 LEDs for operation display and messages <ul style="list-style-type: none"> <li>▪ POWER, AVR STATUS, ALARM</li> <li>▪ RAISE, LOWER, AUTO, MANUAL, REMOTE</li> </ul>

### 13.2 Materials

Front	Aluminum, plastic
Tray/rear	Stainless steel

### 13.3 Dimensions

W x H x D	218 mm x 324 mm x 130 mm (8.58 in x 12.76 in x 5.12 in) (without mating connector) Mating connector 20 mm (0.79 in)
-----------	--

### 13.4 Power supply

Permissible voltage range	85 to 265 V AC / V DC U <sub>N</sub> : 100...240 V AC U <sub>N</sub> : 100...240 V DC
Max. nominal power consumption	25 W
Permissible frequency range	50/60 Hz
Overvoltage category	OC III
Surge test voltage	5 kV, 1.2 µs/50 µs (IEC 60255-27)
Internal fuse	250 V AC, 1.25 A, 5 x 20 mm, T characteristic (slow acting), breaking capacity H (min. 1,500 A), operating temperature -30°C...+100°C)

Table 52: Power supply

Interface	Pin	Description
	2	L
	1	N

Table 53: Connection X9



### Auxiliary power supply AUX DC DI 110 V DC for digital inputs

The auxiliary power supply is used exclusively for the acquisition of up to 16 floating contacts.

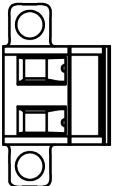
Output voltage	$U_N$ : 110 V DC $\pm$ 2% (short-circuit proof)
Max. output power	5 W
Overvoltage category	OC III
Surge test voltage	5 kV, 1.2 $\mu$ s/50 $\mu$ s (IEC 60255-27)
Fuse	250 V AC, 0.08 A, 5 x 20 mm, TT characteristic (very slow acting), breaking capacity L (min. 35 A), operating temperature -30°C...+85°C

Table 54: Auxiliary power supply

Interface	Pin	Description
	2	L
	1	N

Table 55: Connection X8

## 13.5 Voltage measurement and current measurement

### Voltage measurement

Measuring range (switchable)	132...280 V AC	228...510 V AC
Nominal voltage $U_N$	230 V AC	400 V AC
Accuracy	$< \pm 0.3\% \times U_N$ in the operating temperature range	
Measurement category (IEC 61010-2-30)	CAT III at an altitude of 2,000 m CAT II at an altitude of 3,000 m	
Continuous overvoltage	550 V AC	
Surge test voltage	5 kV, 1.2 $\mu$ s / 50 $\mu$ s (IEC 60255-27)	

### Current measurement

Frequency	45...65 Hz
Nominal current $I_N$	1 A or 5 A (switchable)
Accuracy	$< \pm 0.5\% \times I_N$ in the operating temperature range
Load resistance	$< 0.1 \text{ VA}$

Overload capability continuous	12.5 A
Overload capacity short-term	500 A / 1 s
Surge test voltage	5 kV, 1.2 $\mu$ s / 50 $\mu$ s (IEC 60255-27)

Interface	Pin	Description
	4	N VT (U <sub>N</sub> : 100/230/400 V AC)
	3	L VT
	2	I CT
	1	k CT

Table 56: Connection UI:X7

### 13.6 Central processing unit

Processor	ARM Cortex A9 processor 800 MHz
RAM	512 MB
NVRAM (SRAM with battery backup)	256 kB
Application memory	2 GB
Digital relay outputs	2; galvanically isolated
Nominal voltage	DC 24/48/60 V
Max. continuous current	1 A (ohmic load)
Max. switching capacity	30 W
Rated impulse voltage	2.0 kV

#### Response behavior of the watchdog/error relay:

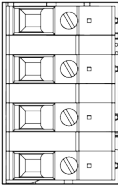
	Error relay	Watchdog relay
Power off	OFF	OFF
Startup	ON	OFF
Ready (no error pending)	OFF	ON
Ready (pending error)	ON	ON

ON: Relay is energized

OFF: Relay is de-energized

**Interfaces**

Interface	Pin	Description
	6	ER_NO
	5	ER_NC
	4	ER_COM
	3	WD_NO
	2	WD_NC
	1	WD_COM

Table 57: Plug terminal CPU:X1

Interface X2, X3	Pin	Description
	8	NC
	7	NC
	6	RXD-
	5	NC
	4	NC
	3	RXD+
	2	TXD-
	1	TXD+

Table 58: Ethernet interface CPU:X2/X3

Interface X4	Pin	Description
	8	NC
	7	NC
	6	GND
	5	NC
	4	NC
	3	NC
	2	TXD+/RXD+
	1	TXD-/RXD-

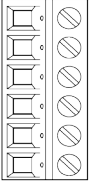
Table 59: Serial interface RS485 CPU:X4

Interface X5	Pin	Description
	8	DTR (O)
	7	DCD (I)
	6	GND
	5	RXD (I)
	4	TXD (O)
	3	VCC/OUT 5 V/12 V
	2	RTS (O)
	1	CTS (I)

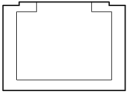
Table 60: Serial interface RS232 CPU:X5

### 13.7 Digital inputs

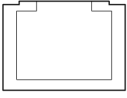
DI 16-110V	
Inputs (plug-based electrical isolation)	2 x 8
Nominal voltage	110 VDC
Max. operating voltage	143 VDC
Logical 0	≤ 55 VDC
Logical 1	≥ 82.5 VDC
Input current	0.9 mA
Simultaneity factor (at 65°C ambient temperature)	Max. 13 inputs

Table 61: DI 16-110V technical data

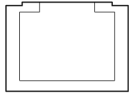
Interface	Pin	Description
	10	Common reference (common)
	9	Common reference (common)
	8	Input 7
	7	Input 6
	6	Input 5
	5	Input 4
	4	Input 3
	3	Input 2
	2	Input 1
	1	Input 0

Table 62: Connector X1 (group 0)



Interface	Pin	Description
	10	Common reference (common)
	9	Common reference (common)
	8	Input 17
	7	Input 16
	6	Input 15
	5	Input 14
	4	Input 13
	3	Input 12
	2	Input 11
	1	Input 10

Table 63: Connector X2 (group 1)

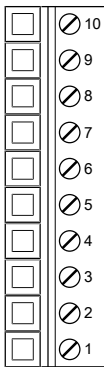
### 13.8 Digital outputs

DO 8	
Outputs (plug-based electrical isolation)	8 relays 4 groups per module
Switching voltage	DC: 24 V, 48 V, 60 V, 110 V, 220 V AC: 110 V, 230 V
Contact load capacity	Min.: 5 V DC, 10 mA Max. DC: See diagram  Max. AC: 250 V; 3 A (8 active outputs) or 5 A (4 active outputs)

Table 64: DO 8 assembly technical data

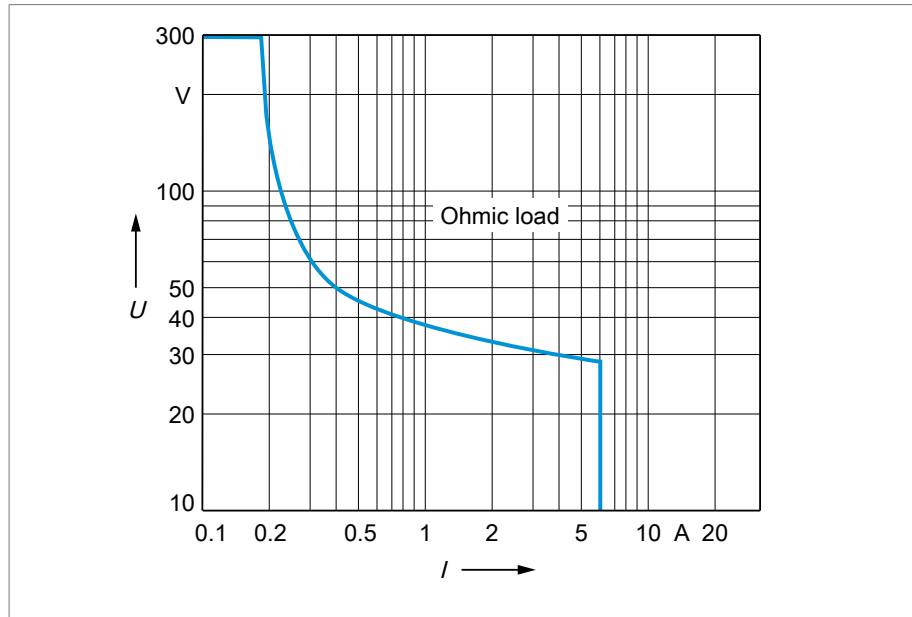

Figure 63: Contact load capacity of digital outputs with resistive load

**CAUTION**



**Electric shock!**

The outputs of the DO assembly have plug-based electrical isolation. A mixture of voltage ranges (e.g. extra low voltage and low voltage) or various phases within a plug can lower the protection against electric shock.

- ▶ Use the same voltage ranges within a plug.
- ▶ Use the same phase within a plug.

Interface	Pin	Description
	4	Common reference (common) output 1
	3	Common reference (common) output 0
	2	Output 1
	1	Output 0

Table 65: Connector X1 (group 0)

Interface	Pin	Description
	4	Common reference (common) output 3
	3	Common reference (common) output 2
	2	Output 3
	1	Output 2

Table 66: Connector X2 (group 1)

Interface	Pin	Description
	4	Common reference (common) output 5
	3	Common reference (common) output 4
	2	Output 5
	1	Output 4

Table 67: Connector X3 (group 2)

Interface	Pin	Description
	4	Common reference (common) output 7
	3	Common reference (common) output 6
	2	Output 7
	1	Output 6

Table 68: Connector X4 (group 3)

### 13.9 Analog inputs

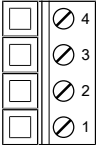
	AI 4
Inputs (electrically isolated)	4 x 1
Measuring range	-20...+20 mA, overcurrent approx. 20% -10...+10 V, overvoltage approx. 30%
Accuracy	0.15% at 25°C Current 0.2% at 0...50°C 0.3% at -20...70°C 0.4% at -40...70°C Voltage 0.4% at 0...50°C 0.5% at -20...70°C 0.6% at -40...70°C
Input impedance	52 Ω at ±20 mA 20.5 kΩ at ±10 V

Table 69: AI 4 assembly technical data

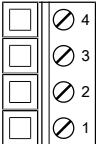
Interface	Pin	Description
	4	V0 U- voltage input
	3	V0 I- current input
	2	V0 I+ current output
	1	V0 U+ voltage output

Table 70: Connector X1 (group 0)

Interface	Pin	Description
	4	V1 U- voltage input
	3	V1 I- current input
	2	V1 I+ current output
	1	V1 U+ voltage output

Table 71: Connector X2 (group 1)

Interface	Pin	Description
	4	V2 U- voltage input
	3	V2 I- current input
	2	V2 I+ current output
	1	V2 U+ voltage output

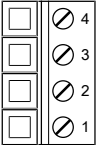
Table 72: Connector X3 (group 2)

Interface	Pin	Description
	4	V3 U- voltage input
	3	V3 I- current input
	2	V3 I+ current output
	1	V3 U+ voltage output

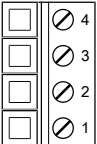
Table 73: Connector X4 (group 3)

### 13.10 Communication interfaces

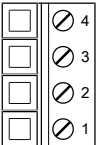
Description	Assembly for converting interfaces and media
Interfaces	1x RS232/RS485 (RJ45): COM X1 2x Ethernet (RJ45): COM X2, COM X5 1x RS232 (D-SUB): COM X3 1x duplex LC (SFP): COM X4 1x plug terminal 10-pin: COM X6
COM X1	Internal system interface for connecting the COM X6 interface to the central processing unit (CPU)
COM X2	Internal system interface for connection the front interface to the central processing unit (CPU)
COM X3	Serial SCADA interface RS232 <ul style="list-style-type: none"> <li>9-pin D-SUB connector</li> </ul>
COM X4	SFP module for converting Ethernet (RJ45) to fiber-optic cable for SCADA <ul style="list-style-type: none"> <li>Max. 2,000 m</li> <li>100 Mbps</li> <li>Light-emitting diode: class 1</li> <li>Wave length: 1,310 nm</li> <li>Max. optical output power: &lt;1 mW (in accordance with IEC 60825-1:2014)</li> </ul>
COM X5	Ethernet connection for SCADA, connection to CPU-X2
COM X6	10-pin plug terminal <ul style="list-style-type: none"> <li>Tap position capture via resistor contact series</li> <li>CAN bus</li> <li>Serial SCADA interface RS485</li> <li>Electrically isolated</li> </ul>

Interface	Pin	Description
	1	CTS (I) (RS232); TXD-/RXD- (RS485)
	2	RTS (O) (RS232); TXD+/RXD+ (RS485)
	3	VCC/OUT 5 V/12 V (RS232)
	4	TXD (O) (RS232)
	5	RXD (I) (RS232)
	6	GND
	7	DCD (I) (RS232)
	8	DTR (O) (RS232)

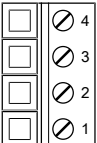
Table 74: COM X1 (RS232/RS485)

Interface	Pin	Description
	1	TxD+
	2	TxD-
	3	RxD+
	4	NC
	5	NC
	6	RxD-
	7	NC
	8	NC

Table 75: COM X2, COM X5 (RJ45)

Interface	Pin	Description
	2	RxD
	3	TxD
	5	GND

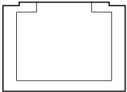
Table 76: COM X3 (RS232)

Interface	Description
	Fiber glass 50/125 and 62.5/125 multimode

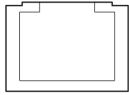
Table 77: COM X4 (duplex LC SFP)

Interface	Pin	Description
	1	GND (resistor contact series)
	2	I out (resistor contact series)
	3	U+ in (resistor contact series)
	4	U- in (resistor contact series)
	5	Data- (RS485)
	6	GND (RS485)
	7	Data+ (RS485)
	8	CAN L (CAN bus)
	9	CAN GND (CAN bus)
	10	CAN H (CAN bus)

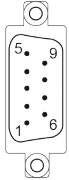
Table 78: COM X6

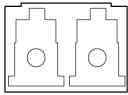

### 13.11 Tap position capture / resistor contact series

Electrical isolation	Test voltage power-frequency withstand voltage: 500 V <sub>eff</sub> ; 50 Hz; 1 min
Tap position capture	35 tap positions, 2,000 ohms

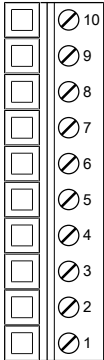
### 13.12 Ambient conditions

Operating temperature	-25...+70°C
Storage temperature	-30...+85°C (with battery)
Relative humidity	5...95%, non-condensing
Contamination level	2
Protection class	I
Degree of protection	Front: IP54 Rear: IP20 With optional housing: IP66
Maximum installation altitude	3,000 m above mean sea level
Minimum clearance to other devices / control cabinet	Above/below: 88.9 mm (3.5 in; equivalent to 2RU), behind 30 mm (1.2 in)

Table 79: Permissible ambient conditions

### 13.13 Standards and directives

Electromagnetic compatibility	IEC 61000-6-2, IEC 61000-6-4, IEC 61000-6-5 EN 60255-26 KN 61000-6-2, KN 61000-6-4 FCC 47 CFR Part 15 B ICES-003
Electrical safety	IEC 61010-1 IEC 61010-2-201 IEC 61010-2-030 EN 61010-1 UL 61010-1 CAN/CSA-C22.2 No. 61010-1
Measurement relays and protective devices	IEC 60255-1:2009 Section 6.10.1, 6.10.2 and 6.10.4 IEC 60255-27:2013 Section 10.6.4.2, 10.6.4.3, 10.6.4.4 and 10.6.5.3



Climatic ambient conditions	IEC 60068-2-1 (-25°C; 96 h) cold IEC 60068-2-2 (+70°C; 96 h) dry heat IEC 60068-2-78 (+40°C / 93% rH, 96 h) moist heat, constant IEC 60068-2-30 (+55°C, 6 cycles 12 + 12 hours) moist heat, cyclical
Degree of protection test	IEC 60529
Environmental durability tests	IEC 60255-21-1 vibrations class 1 (3 cycles, 0.5g acceleration, 1 octave/min or 60 cycles, 1.0g acceleration, 1 octave/min) IEC 60255-21-2 shock class 1 (duration 11 ms, 5g or 15g acceleration, number of axes 3) IEC 60255-21-3 seismic class 1 (frequency 1–35 Hz, 3.5 mm/1g acceleration horizontal, 1.5 mm/0.5g acceleration vertical, 1 octave/min, duration 10 min/axis) IEC 60068-2-6 Vibration sinusoidal IEC 60068-2-27 shock

Table 80: Standards and directives



## 13.14 Connection diagrams

### Also refer to

 TAPCON® 230 AVT [[▶ 150](#)]

# TAPCON® 230 - AVT

POWER SUPPLY

CENTRAL PROCESSING UNIT

DIGITAL OUTPUTS DO 8-1

DIGITAL INPUTS DI 16-110V

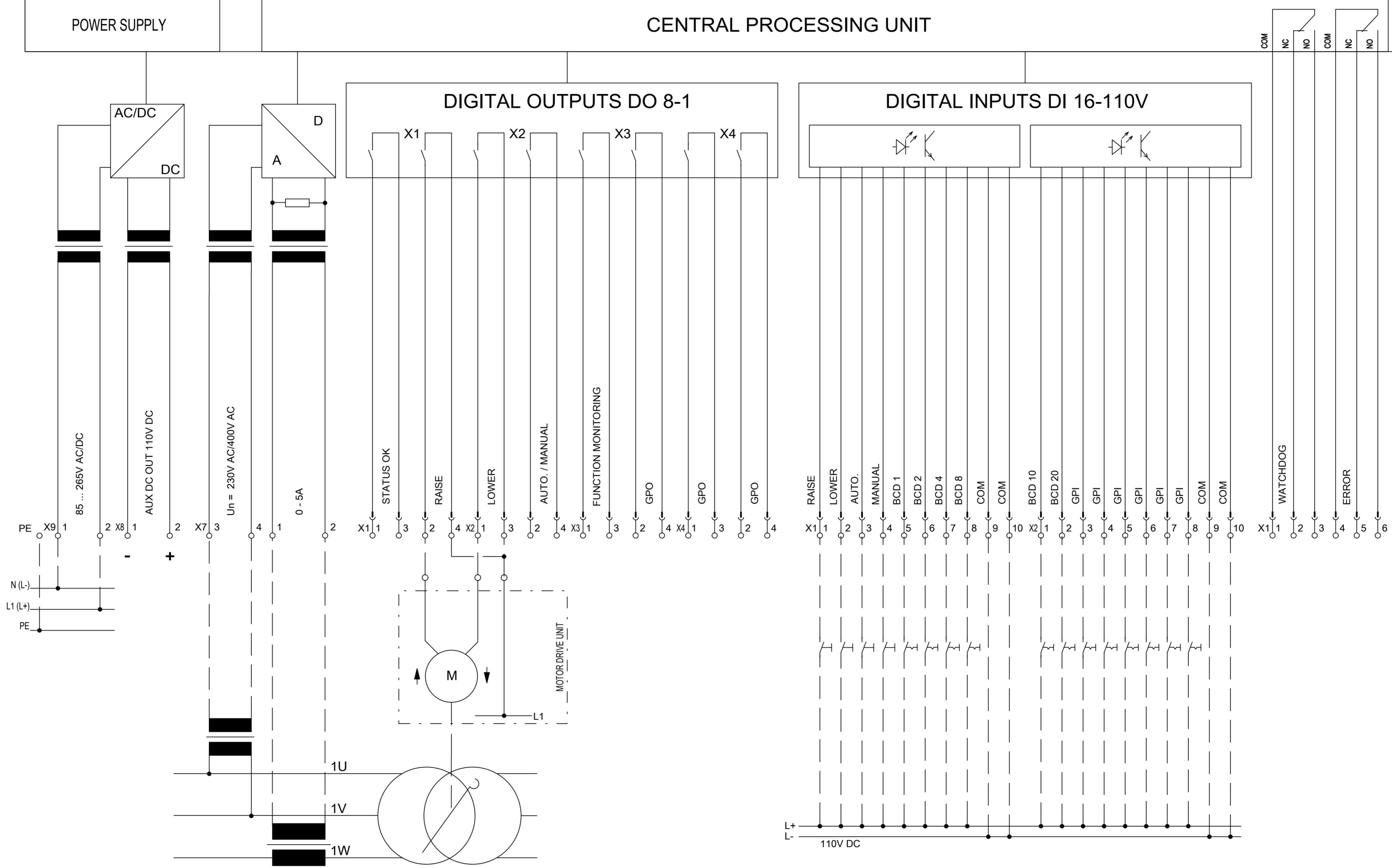

Fuer diese technische Unterlage behalten wir uns gemass  
DIN 34 Abschnitt 2.1 und 2.2 alle Rechte vor.

DRAWING BY CAD  
DO NOT MODIFY MANUALLY

02	X7,X1,X6 connection	01.10.21	LAINER	DATE	22.01.2021
01	BCD SIGNAL	30.06.21	KAHN	EXEC.	BECK
				VERIFIED	AP
NO.	MODIFICATION	DATE	NAME	STANDARD	

ORIGIN	REPL	REPL BY



TAPCON® 230 AVT

LANGUAGE:  
EN

PROJECT:  
7870284\_02

=	
+	
	SHEET 1
	3 SH.

# TAPCON® 230 - AVT

CENTRAL PROCESSING UNIT

COM

DIGITAL OUTPUTS DO 8-2

ANALOG INPUTS AI 4

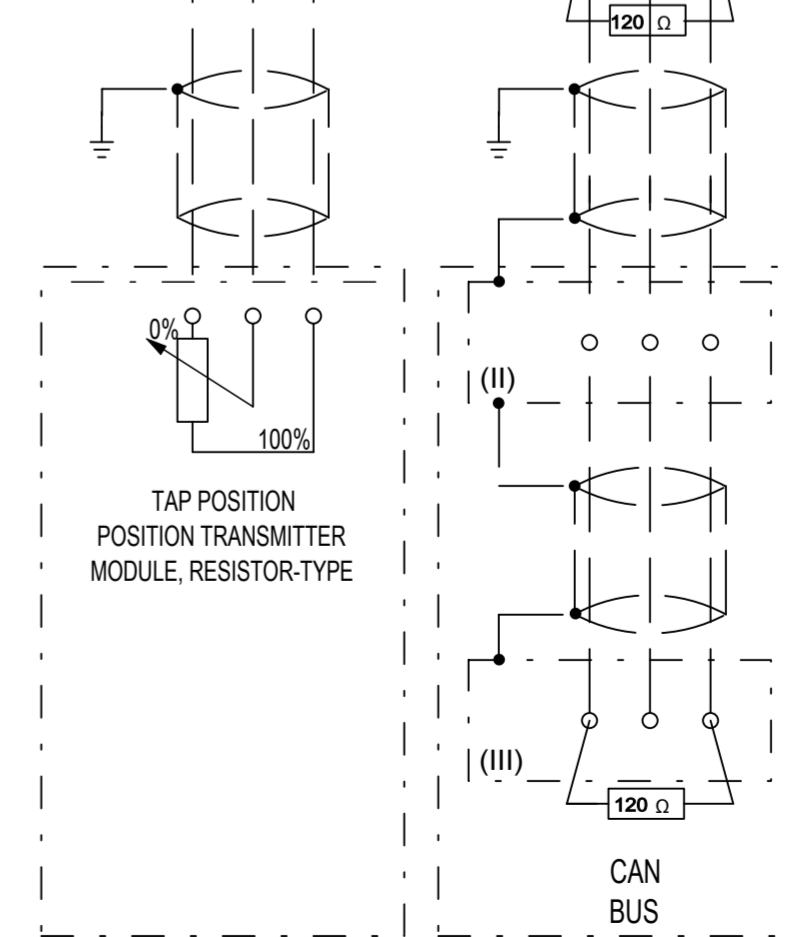
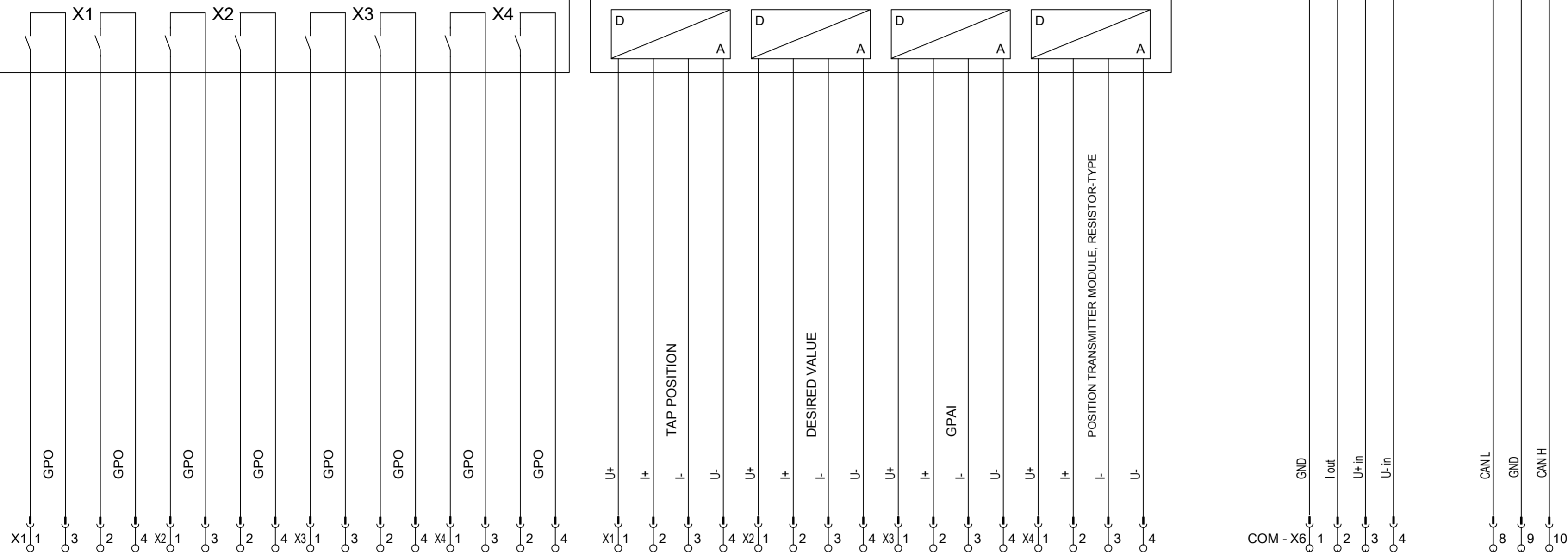

Fuer diese technische Unterlage behalten wir uns gemaess  
DIN 34 Abschnitt 2.1 und 2.2 alle Rechte vor.

DRAWING BY CAD  
DO NOT MODIFY MANUALLY

02	X7,X1,X6 connection	01.10.21	LAINER	DATE	22.01.2021
01	BCD SIGNAL	30.06.21	KAHN	EXEC.	BECK
				VERIFIED	AP
NO.	MODIFICATION	DATE	NAME	STANDARD	ORIGIN
					REPL
					REPL BY



TAPCON® 230 AVT

LANGUAGE:  
EN

PROJECT:  
7870284\_02

=	
+	
	SHEET 2
	3 SH.

CUSTOMER

COM

CPU

RJ45

RJ45

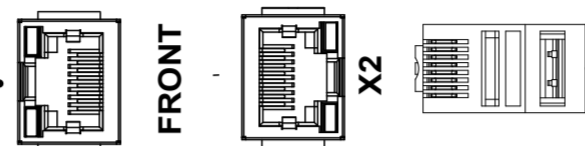

VISU / SERVICE

x3 RJ45

x3 RJ45

LC 1310nm

RJ45

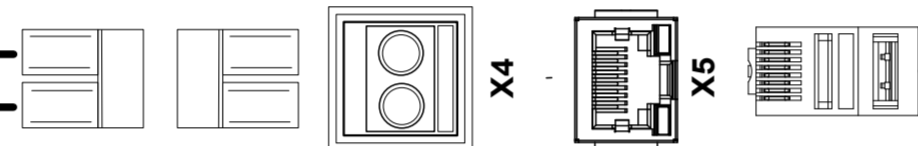

SCADA ETHERNET

x2 RJ45

x2 RJ45

PIN	SIGNAL
2	RxD
3	TxD
5	GND

RS232

PIN	SIGNAL
5	Data -
6	GND
7	Data +

RS485

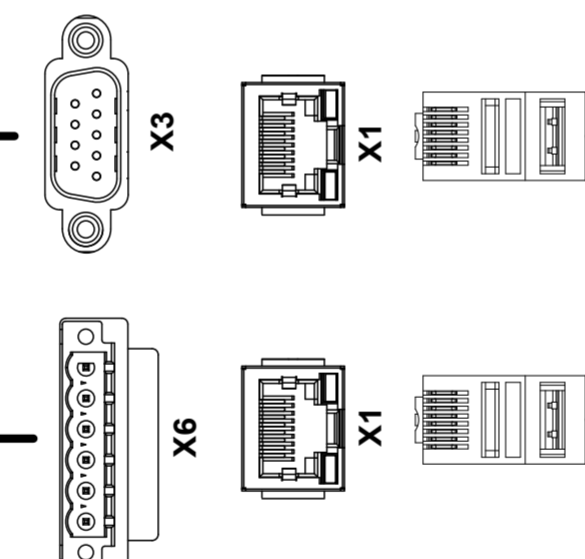

SCADA SERIAL

x5 RJ45

x4 RJ45

Fuer diese technische Unterlage behalten wir uns gemass DIN 34 Abschnitt 2.1 und 2.2 alle Rechte vor.

DRAWING BY CAD DO NOT MODIFY MANUALLY

02	X7,X1,X6 connection	01.10.21	LAINER	DATE	22.01.2021
01	BCD SIGNAL	30.06.21	KAHN	EXEC.	BECK
				VERIFIED	AP
NO.	MODIFICATION	DATE	NAME	STANDARD	



TAPCON® 230 AVT

LANGUAGE: EN

PROJECT: 7870284\_02

=	
+	
SHEET	3
	3 SH.



## Glossary

### **EMC**

Electromagnetic compatibility

### **GPI**

General Purpose Input

### **GPO**

General Purpose Output

### **IP**

Internet Protocol

### **OF**

Abbreviation for fiber-optic cable

### **SCADA**

Technical processes are monitored and controlled using a computer system (Supervisory Control and Data Acquisition)

### **SNTP**

NTP (Network Time Protocol) is a standard for synchronizing clocks in computer systems using packet-based communication networks. SNTP (Simple Network Time Protocol) is the simplified version of NTP.

### **TDSC**

TAPCON® Dynamic Set Point Control





**Maschinenfabrik Reinhausen GmbH**

Falkensteinstrasse 8  
93059 Regensburg

☎ +49 (0)941 4090-0

✉ [sales@reinhausen.com](mailto:sales@reinhausen.com)

[www.reinhausen.com](http://www.reinhausen.com)

7820299/03 EN - TAPCON® 230 AVT -

- 11/21 - Maschinenfabrik Reinhausen GmbH 2021

THE POWER BEHIND POWER.

