



Reyrolle
Protection
Devices

7SR105 Rho

Motor Protection Relay

Energy Management

SIEMENS

7SR105 Rho

Motor Protection Relay



Description

The 7SR105 Rho motor protection relay is developed by using the latest generation of hardware technology. 7SR105 is a member of Siemens Reyrolle® protection devices Rho product family.

The 7SR105 Rho motor protection relay is housed in a 4U high, size 4 non draw-out case and these relays provide protection, monitoring, instrumentation, and metering with integrated input and output logic, data logging and fault reports. Communication access to the relay functionality is via a front USB port for local PC connection or rear electrical RS485 port for remote connection.

Function Overview

Protection

14	Stall Protection
46	Phase Unbalance Protection
49	Thermal Overload Protection
48/66	Start Protection
37	Undercurrent Protection
50	Instantaneous Overcurrent Protection
50N/G	Instantaneous Derived/Measured Earth Fault
51	Time Delayed Overcurrent Protection
51N/G	Time Delayed Derived/Measured Earth Fault Protection

Supervision

74 T/CCS	Trip and Close Circuit Supervision
81B	Anti Backspin
46PhRev	Phase Reversal
50BCL	Breaking Capacity Limit
50BF	Circuit Breaker Fail
TEMP	Temperature Input Monitoring

Control

- 86 Lockout
- Motor Start/Stop Control
- User Programmable Logic

Features

- Two Settings Groups
- Password Protection – 2 levels
- User Programmable Logic
- Self Monitoring
- Circuit Breaker Trip and Maintenance Counter
- Trip Timers

User Interface

- 20 Character x 4 Line Backlit LCD
- Menu Navigation Keys
- 9 User Programmable Tri-colour LEDs
- Dedicated motor start and stop push buttons

Monitoring Functions

- Primary/Secondary Current Phases and Earth
- Positive Phase Sequence (PPS) Current
- Negative Phase Sequence (NPS) Current
- Zero Phase Sequence (ZPS) Current
- Thermal equivalent and unbalanced currents
- Binary Input/Output status
- Time and date
- Starters
- Fault records
- Event records
- Circuit breaker trip counters and Time to trip
- I²t summation for contact wear
- Temperature input values

Hardware

- 4 CT 6 Binary Inputs/6 Binary Outputs 10 LEDs
- 4 CT 6 Binary Inputs/6 Binary Outputs 10 LEDs 6 RTD

Data Storage and Communication

- Front USB port + Rear RS485 port
- Protocols - IEC60870-5-103, DNP3.0 or Modbus RTU
- Event Records - User Configurable
- Fault Records
- Waveform Records
- Measurands
- Commands
- Time Synchronism
- Viewing and Changing Settings
- Maximum Temperature recorded input

Application

7SR105 Rho motor protection relay is a numerical protection relay intended for use in the motor protection applications. It provides a highly comprehensive functional software package with a range of integral application functions aimed at reducing installation, wiring, and engineering time.

A wide range of measured values can be viewed on the front LCD or remotely via the communication channel.

The integrated control feature allows the safe operation of a motor and monitoring its start and stop operations.

7SR105 Functional Diagram

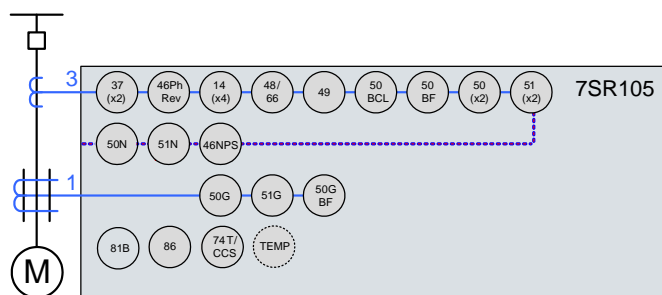

Fig 1. 7SR105 Rho Motor Protection Relay

Description of Functionality

14 Stall Protection

Each element has a single definite time overcurrent characteristic with settings for pickup level and Definite Time Lag (DTL) delays.

Operation can be controlled from motor stopped or running conditions.

37 Undercurrent Protection

Each element has settings for the pickup level and the definite time lag (DTL) delay. The element operates when current falls below setting for the duration of the delay.

46 Phase Unbalance Protection

Unbalance current has a significant heating effect on the motor.

Two phase unbalance measurement modes are available. Either NPS current or the difference between maximum and minimum phase currents can be used as a measurement of the unbalance level.

Inverse or definite time operation can be selected.

48/66 Start Protection

The feature provides settings to control both the number of times a motor can be started within a specified time period and the minimum time between starts. Motor starting can be inhibited when this limit is reached. Motor start time can also be monitored.

49 Thermal Protection – Rotating Plant

The operating curves take into account the effects of present loading, prior loading and unbalanced currents on the motor operating temperature.

A user definable thermal curve is selectable to allow matching of the relay thermal characteristic to all motor and cooling system types.

'Starting' and 'cooling' constants modify the thermal characteristic during motor run-up and stopped conditions. The enhanced thermal algorithm provides compliance with IEC60255-8 (Thermal Electrical relays).

50/51 G/N Earth Fault Protection

Two earth fault measurement modes are available.

Measured earth fault mode (G) directly measures the earth current from an independent CT, or the residual connection of the 3 line CT's.

Derived earth fault mode (N) derives the earth current internally from the line CT inputs.

Independent settings are available for pickup current and time-delays.

IDMT curves are available.

50/51 Overcurrent Protection

Definite time elements provide short circuit overcurrent protection with independent settings for pickup current and time-delays.

IDMT curves can also be selected.

50BF Circuit Breaker Fail

The circuit breaker fail function may be triggered from an internal trip signal or from a binary input. Where a CB closed is detected following a trip signal an output is issued after a specified time interval. This can be used to re-trip the CB or to back-trip an upstream CB. A second time delay is available to enable another stage to be utilized if required.

81B Anti Backspin

To inhibit attempted restarting of the motor until after the rotor has completely stopped backspin protection is applied. Starting is inhibited until the 81B time delay has elapsed.

TEMP Temperature Inputs

Motor resistance temperature detectors (RTDs) can be connected via temperature inputs. Up to six RTD sensors can be monitored. Provision to configure seven types of RTD inputs (for 3 wire configuration). Temperature inputs can be configurable for RTD Alarm and Trip application.

NOTE:

Any one of the RTD type can be configured for all six temperature inputs.

74TCS Trip Circuit Supervision

The trip circuits can be monitored via binary inputs connected in H5/H6 or H7 schemes. Trip circuit failure raises an HMI alarm and output(s).

Programmable User Logic

The user can map Binary Inputs and Protection operated outputs to Function Inhibits, Logic Inputs, LEDs and/or Binary Outputs.

The user can also enter up to 4 equations defining scheme logic using standard functions e.g. Timers, AND/OR gates, Inverters and Counters.

Each Protection element output can be used for Alarm/Indication and/or tripping.

Function LED's

Ten user programmable tri-colour LED's are provided eliminating the need for separate panel mounted indicators and associated wiring. Each LED can be user set to red, green or yellow allowing for indication of the associated function's status. A slip-in pocket adjacent to the LEDs enables the user to insert customised labels. A printer compatible template is available.

Virtual Inputs/Outputs

There are 8 virtual inputs/outputs to provide internal logical states to assist in the application of the functions. Each virtual I/O can be assigned in the same way as a physical I/O.

Circuit Breaker Maintenance

Two circuit breaker operations counters are provided to assist with maintenance scheduling. The maintenance counter records the overall number of operations and the delta counter records the number of operations since the last reset.

An I²t summation counter provides a measure of the contact wear indicating the total energy interrupted by the circuit breaker contacts.

Each counter has a user set target operations count which, when reached, can be mapped to raise alarms/binary outputs. A CB Trip Time meter is also available, which measures the time between the trip or open command being issued and the auxiliary contacts changing state.

Control Mode

The relay has a control menu with access to commonly used command operations. Access to the control commands is restricted by a 4 character control function password. Each command requires a select then execute operation, if the execute operation is not performed within a time window the command is aborted.

Motor Start/Stop

The motor control function is used to manually start and stop the motor when it is connected to the power network. Two dedicated push buttons are provided on the HMI to execute the motor manual start and stop operations.

Data Acquisition - Via Communication Interface

Sequence of Event Records

Up to 1000 events are stored and time tagged to 1 ms resolution.

Fault Records

The last 15 fault records are displayed on the relay fascia and are also available through the communication interface with time and date of trip, measured quantities and type of fault.

Waveform Recorder

The waveform recorder stores analogue data for all poles and the states of protection functions, binary inputs, LEDs, and binary outputs with user settable pre and post trigger data. A record can be triggered from protection function, binary input or via data communications. 15 records of 1 second duration are stored.

Demand Metering

A rolling record of demand over the last 24 h is stored. The demand is averaged over a user selectable period of time. A rolling record of such demand averages is stored and provides the demand history. A typical application is to record 15 min averages for the last 7 days.

Real Time Clock

The time and date can be set and are maintained while the relay is de-energised by a back up storage capacitor. The time can be synchronized from a binary input pulse or the data communication channel.

Language Editor

The Language editor software gives the user the ability to customize the text displayed in the relays, Menu structure and instrumentation views. The tool allows a language file to be created and transferred to the relay also containing Western European characters.

The data acquisition via communication interface can be done by Reydisp Evolution.

Serial Communications

The relay offers a USB serial port as standard on the front of all units. All of the relays functions can be set on a PC using Reydisp Evolution via the USB port. The connection is made with a USB cable and operates with a 'plug and play' connection, so no pre-setting of the relay is required.

The front port can be switched off or set to use either the DNP3.0, MODBUS-RTU, IEC60870-5-103 and ASCII protocols for testing purposes.

A rear RS485 electrical connection is optionally available on the relay for system interface connections. An internal terminating resistor is provided, which can be connected into the circuit by adding a wire loop between the relevant terminals.

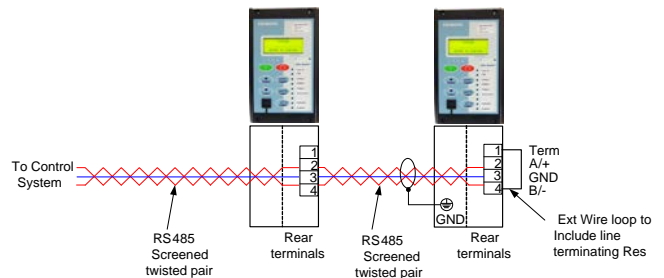

Fig 2. Typical RS485 connection

The rear RS485 can be user selected to be OFF, IEC60870-5-103, MODBUS RTU or DNP3.0 protocol.

Construction

The relay is housed in a non draw-out case 4U high, size 4 case.

The rear connection comprises of user friendly pluggable type terminals for wire connections for BI, BO, Communication, Temperature inputs, and Power Supply.

The CT terminals are suitable for ring type lug connection to provide a secure and reliable termination.

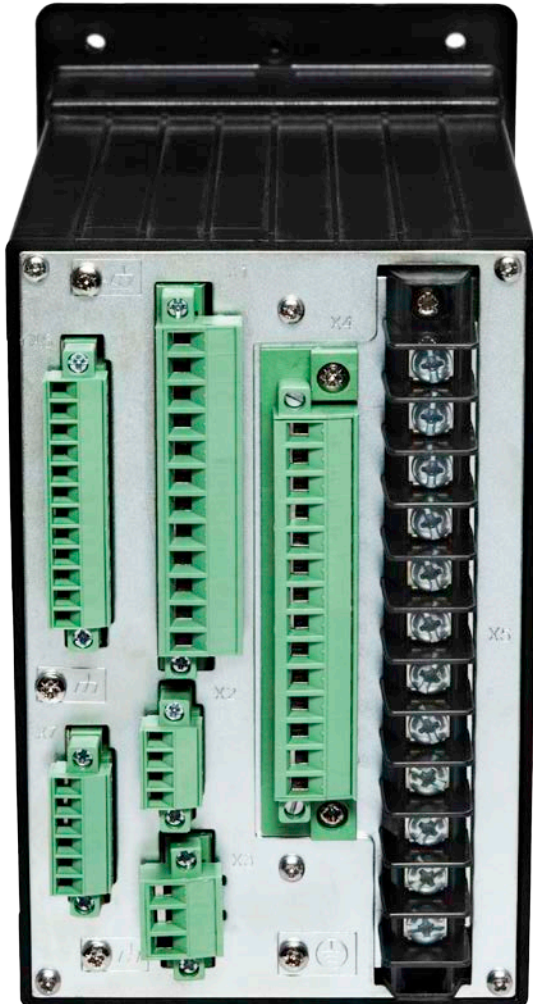

User Interface

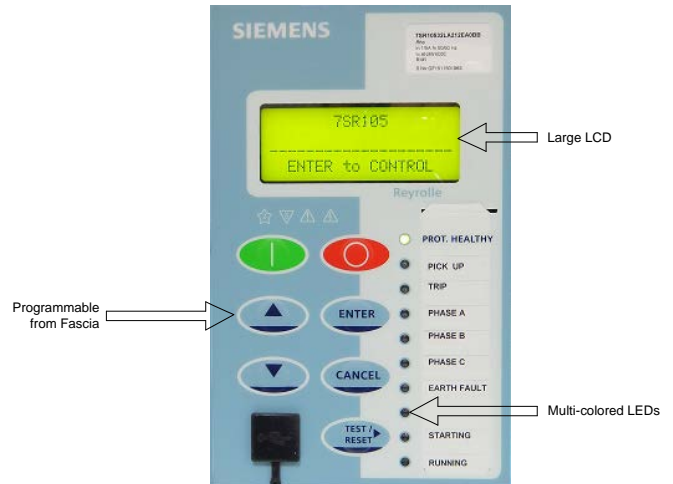

Fig 3. User Interface

The operator interface is designed to provide a user friendly method of controlling, viewing menus, entering settings, and retrieving data from the relay. Five buttons are provided for navigation around the menu structure.

Two dedicated push buttons are provided on the HMI to execute the motor manual start and stop operations.

LCD

A 4 line by 20 character liquid crystal display with power save operation indicates the relay identifier, settings, instrumentation, fault data and control commands. Up to 6 user programmable general alarms can be configured to display your own indications on the LCD.

LEDs

A green steadily illuminated LED indicates the 'Protection Healthy' condition. 9 users programmable LEDs are available eliminating the need for expensive panel mounted pilot lights and associated wiring. Each LED is tri-color (red, green, yellow) allowing for clear indication of the associated function's state and has a label for identification.

Relay Information

The device is identified by the rating label on the front fascia. The user can also give the device its own identity by editing the 'Relay Identifier' displayed on the LCD.

Indication of Conformity



This product complies with the directive of the Council of the European Communities on harmonization of the laws of the Member States relating to electromagnetic compatibility (EMC Council Directive 2014/30/EU) and concerning electrical equipment for use within specified voltage limits (Low Voltage Directive 2014/35/EU).

This conformity has been proved by tests performed according to the Council Directive in accordance with the generic standard IEC/EN 60255-26 (for EMC directive) and with the standards IEC/EN 60255-27 (for Low Voltage Directive) by Siemens AG.

Technical Data

For full technical data, refer to the Technical Specification Section of the User Manual.

Technical Data Overview

Product Family (Auxiliary powered)	Motor Protection Relay
Case and LEDs	Non Draw-out Polycarbonate case (Size 4 standard, Non Draw-out design), 10 LEDs
Measuring Inputs (Current)	1 A/5 A, 50 Hz/60 Hz
Auxiliary Voltage	60 V - 240 V AC/DC 24 V - 60 V DC
Communication	Default front communication port (IEC 60870-5-103 or MODBUS RTU) Rear port: RS485 (optional - IEC 60870-5-103 or Modbus RTU or DNP 3.0)
Protection Functions	14, 37, 48/66, 50, 50G/N, 51, 51G/N, 49, 46
Supervision and control functions	74 T/CCS, 86, 50 BCL, 81 B, 46 Ph Rev, 50BF, TEMP
Binary Input and Binary Output	6 BI and 6 BO (2 changeover contact) Threshold voltage - 44 V AC/DC with 60 V - 240 V AC/DC power supply version - 19 V DC with 24 V - 60 V DC power supply version
Overvoltage	Category III
Pollution Degree	2

Mechanical Specifications

Design	Flush mounting, Non Draw-out Polycarbonate moulded case
Enclosure	IP 54 (front panel) IP 20 Protection for terminals (rear side) Depth is 199 mm
Weight	1.6 kgs (appx)

Terminal Blocks

Current Inputs	12 position, M4 Screw-type Barrier Terminal block suitable for 2.5 mm ² /4 mm ² cable
Auxiliary Supply	3 position, M3 screw-type plug-in terminals suitable for 2.5 mm ² cable
Rear Communication Port	4 position, M2 screw-type plug-in terminals suitable for 1.5 mm ² cable
Front Communication Port	USB, Type B
Binary Input	12 position, M3 screw-type plug-in terminals suitable for 2.5 mm ² cable
Binary Output	14 position, M3 screw-type plug-in terminals suitable for 2.5 mm ² cable

Temperature Inputs	18 position (Terminal X6, X7), M2 screw-type plug-in terminals suitable for 1.5 mm ² shielded cable
--------------------	----------------------------------------------------------------------------------------------------------------

Inputs and Outputs

Current Inputs

Quantity	3 x Phase & 1 x Earth
Rated Current In	1 A/5 A
Measuring Range	80*In 8*In (Measure E/F)
Instrumentation	±1 % (Typical) (≥ 0.1xIn to 3xIn) ± 3 % (> 3xIn to 80xIn)
Frequency	50 Hz (Range: 47.5 Hz to 52.5 Hz) 60 Hz (Range: 57 Hz to 63 Hz)
Thermal Withstand:	
Continuous	4 x In
10 seconds	30 x In
1 Second	100 A (1 A) 350 A (5 A)
Burden @ In	≤ 0.3 VA per phase and earth for both 1 A and 5 A

Auxiliary Supply

Rated Voltage	60 V - 240 V AC/DC, Tolerance -20% to +10%
Allowable super imposed AC component	15% of DC voltage
Typical power consumption (DC)	< 7 W
Typical power consumption (AC)	<7 VA 0.5 PF
Max Interruption time (Collapse to Zero)	≤100 ms (110 V DC) ≤ 1000 ms (230 V AC)

Auxiliary Supply

Rated Voltage	24 V - 60 V DC Tolerance -20% to +10%
Allowable super imposed AC component	15% of DC voltage
Typical Power consumption (DC)	< 7 W
Max Interruption time (Collapse to Zero)	20 ms (24 V DC)

Binary Inputs

Number	6	
Operating Voltage*	19 V DC	Range 24 V - 66 V DC
	44 V AC/DC	Range 44 V - 265 V
	Range	DC 44 V - 265 V DC AC 36 V - 265 V AC
Maximum AC/DC current for operation	3.5 mA	
Pick Up Delay	User selectable 0 to 14,400,000 ms (up to 4 hours)	
Drop Off Delay	User selectable 0 to 14,400,000 ms (up to 4 hours)	

Reset/Operate voltage ratio	≥ 90%
Response time	< 9 ms

*Refer to ordering information for more details.
For more details about binary inputs, refer to Technical Manual.

Binary Outputs

Number	6 4 NO contacts and 2 change over contacts
Operating Voltage	Voltage Free
Operating Mode	User selectable - Self or Hand/Electrical Reset or pulsed
Operating Time from energizing Binary Input	< 20 ms
Making Capacity: Carry continuously Make and carry (L/R ≤ 40 ms and V ≤ 300 V)	5 A AC or DC 20 A AC or DC for 0.5 s 30 A AC or DC for 0.5 s
Breaking Capacity (≤ 5 A and ≤ 300 V): AC Resistive AC Inductive DC Resistive DC Inductive	1250 VA 250 VA at p.f. ≤ 0.4 75 W 30 W at L/R ≤ 40 ms 50 W at L/R ≤ 10 ms
Disengaging time	< 20 ms

Temperature Inputs

Number	6
Measuring Range	-50 °C to +250°C
Response time	< 3 s
Sensing current	< 0.5 mA

Rear Communication Port

Quantity	1 No.
Electrical connection	RS485, 2 wire electrical
Protocol Support	MODBUS RTU, IEC 60870-5-103, DNP 3.0
Rate	Data Transfer rate: 2400 - 38400 bps

Front Communication Port

Quantity	1 No.
Electrical connection	USB, Type B

Data Storage

Fault Record	15
Waveform Record	15 Rec x 1 Sec 7 Rec x 2 Sec 3 Rec x 5 Sec 1 Rec x 15 Sec Pre trigger 10...90 %
Events	1000 events (1 ms Resolution)

Mechanical Tests

Test	Standard
Vibration	IEC 60255-21-1 Response and Endurance, Class I
Shock and Bump	IEC 60255-21-2 Shock response and withstand Class I Bump, Class I
Degree of Protection	IEC 60529 IP 54 front IP 20 back
Seismic	IEC 60255-21-3, Class I
Contact	IEC 60255-1 (Ref: Std IEC 61810-1)
Electrical Endurance Test	IEC 60255-1 (Ref: Std IEC 61810-1) (10000 operations at 250 V, 5 A)

Electrical Tests

Test	Standard
Insulation Resistance	IEC 60255-27# 500 V DC, >100M Ohms
Impulse Voltage Withstand	IEC 60255-27# 5 kV, 5 +ve, -ve pulses
Hi Voltage (Dielectric) Voltage	IEC 60255-27# 2 kV@1 min (Between any terminal and earth, independent circuits) 1 kV AC RMS for 1 min (across normally open contacts)
High Frequency Disturbance	IEC 60255-26 2.5 kV (CM), 1.0 kV (DM) 1 MHz
Electrostatic Discharge	IEC 60255-26 8 kV air discharge 6 kV contact discharge
Electrical Fast Transient or Burst *	IEC 60255-26, Zone A 4 kV, 5 kHz
Surge Immunity *	IEC 60255-26, Zone A 4 kV (CM), 2 kV (DM) 1.2/50 μs
Radiated Immunity	IEC 60255-26 80 MHz to 1.0 GHz and 1.4 GHz to 2.7 GHz Both frequency at 10 V/m
Conducted Radio Frequency Interference	IEC 60255-26 150 kHz to 80 MHz
Power Frequency Magnetic Field	IEC 60255-26 30 A/m applied 1 min, 300 A/m applied for 3 s
Conducted Emissions	IEC 60255-26 CISPR 22, Class A
Radiated Emissions	IEC 60255-26 CISPR 11, Class A

Thermal Withstand Continuous 1 s Burden	IEC 60255-27 4 x In 100 A (1 A) 350 A (5 A) IEC 60255-1 ≤ 0.3 VA per phase and earth for both 1 A and 5 A
Functional	IEC 60255-8
Temperature Input (Pt100)	IEC 60751
Maximum Allowable Temperature	IEC 60255-6 Max. temperature limit +100 °C
Limiting Dynamic Value	10 ms 700 A (1 A) 2500 A (5 A)
Gradual shutdown/ Start-up test	IEC 60255-26 Shut down/start up ramp 60 s Power off 5 min

* **NOTE:** 45 ms DTL pick-up delay applied to binary inputs

NOTE: All aspect of IEC 60255-5 have been covered under IEC 60255-27

Climatic Environmental Tests

Temperature

IEC 60255-1/IEC 60068-2-1/IEC 60068-2-2

Operating Temperature	-10 °C to + 60 °C
Storage Range	- 25 °C to + 70 °C

Humidity

IEC 60255-1/IEC 60068-2-30/IEC 60068-2-78

Damp heat test, Cyclic	6 days at 40 °C and 93 % relative humidity
Damp heat test, Steady State	10 days at 95 % RH, +40 °C
Maximum Altitude of Operation	Upto 2000 m

Product Safety Test

IEC/EN 60255-27

Type Test	Parameters	Values
Clearances and Creepage Distances	Clearances and creepage distances between external circuits mutual and to the enclosure	≥ 4 mm
Protective Bonding Resistance	Test voltage: < 12V AC/DC	< 0.1 Ohm
	Test duration: 1 min	
	Bonding resistance	
Protective Bonding Continuity	Accessible conductive parts should be bonded with the protective conductor terminal	Low current continuity test
Flammability of Insulating Materials, Components and Fire enclosures	Structure Part	Standard for insulating material of flammability class
	Terminals	Class UL 94 V-0

Type Test	Parameters	Values
	Terminal mounting	Class UL 94 V-0
	Wiring (CT)	(N)2GFAF(VDE)
	Components mounting	Class UL 94 V-0
	Enclosure	Class UL 94 V-0
	PCB	Class UL 94 V-0
	LCD	Class UL 94 V-0
Single Fault Condition	Assessment of: - Insulation between circuits and parts - Compliance with requirements for protection against the spread of fire - Overloads - Intermittently rated resistors - Compliance with requirements for mechanical protection	The equipment shall not present a risk of electric shock or fire after a single-fault test.

Performance

14 Stall Protection

Number of Elements	4
Setting Range Is: -	0.05 to 10 x In
Time Delay	0.00 to 14400 s
Operate Level	100 % Is ± 5 % or ± 1 % x In
Operate time 2 x Is 5 x Is	35 ms ± 10 ms, 25 ms ± 10 ms
Operate time following delay	t _{basic} + t _d , ± 1 % or ± 10 ms
Controlled by	Stopped, No acceleration, Running, None
Disengaging time	< 50 ms

37 Undercurrent

Number of Elements	2
U/C Guard	0.05 to 5.0 x In
Setting Range Is	0.05 to 5.0 x In
Operate Level	100 % Is ± 5 % or ± 1 % x In
Delay Setting t _d	0 to 14400 s
Basic Operate Time: - 0.5 x Is	35 ms ± 20 ms
Operate time following delay.	t _{basic} + t _d , ± 1 % or ± 10 ms
Overshoot Time	< 40 ms
Inhibited by	Binary or Virtual Input
Disengaging time	< 60 ms

46 Phase Unbalance Protection

Number of Elements	1 (Magnitude difference or NPS)
Setting Range Is	0.1 to 0.4 x Itheta
Operate Level	100 % Is ± 5 % or ± 1 % x In
IT Min. Operate Time	0 to 20 s
DT Delay Setting td	0 to 20 s
DT Basic Operate Time for NPS -	
2 x Is	65 ms ± 10 ms
5 x Is	60 ms ± 10 ms
DT Basic Operate Time for magnitude -	
2 x Is	60 ms ± 10 ms
5 x Is	50 ms ± 10 ms
DT Operate time following delay	td ± 1 % or ± 30 ms
Tm Time Multiplier	0.025 to 2.0
Disengaging time	< 80 ms
Inhibited by	Binary or Virtual Input

48/66 Start Protection

Max. No. of Starts	OFF, 1 to 20
Max. Starts Period	1 to 60 minutes
Start Inhibit Delay	1 to 60 minutes
Time Between Starts	OFF, 1 to 60 minutes

49 Thermal Protection

Setting Range Itheta	0.1 to 3.0 x In
NPS Weighting Factor (K)	0.1 to 10.0 Δ 0.1
TauH Heating Constant	0.5 to 1000 mins, Δ 0.5 mins
TauS Starting Constant	0.005 to 1.0 x TauH, Δ 0.005
TauC Cooling Constant	1 to 100 x TauH, Δ 1
Hot/cold ratio	OFF, 1 to 100 %, Δ 1 %
Operate Level	100 % Is, ± 5 % or ± 1 % x In
Operate time	$\tau = \tau \times In \left\{ \frac{I_{EQ}^2 - \left(1 - \frac{H}{C}\right) I_p^2}{I_{EQ}^2 - I_\theta^2} \right\}$ ± 5 % or ± 100 ms (Itheta = 0.3 to 3 x In) (1.2 to 20 x Itheta) User defined
Capacity Alarm Level	Disabled, 50, 51... 100 %
Load Alarm Level	OFF, 0.5 to 1.0 x Itheta, Δ 0.05
Thermal restart inhibit	20 to 100 %, Δ 1 %
Inhibited by	Binary or Virtual Input

50 Instantaneous & DTL OC&EF

Operation	Non directional
Elements	Phase, Derived Earth, Measured Earth
Setting Range Is (50/50N)	0.05, 0.06... 50 x In
Setting Range Is (50G)	0.01, 0.011, ..., 5 x In
Time Delay	0.00... 14400 s
Operate Level Iop	100 % Is, ± 5 % or ± 1 % x In
Reset level	≥ 95 % Iop
Reset level (50G)	≥ 95 % Iop or Iop - 0.1 % In
Operate time:	
50, 50G	0 to 2x Is - 35 ms, ± 10 ms, 0 to 5x Is - 25 ms, ± 10 ms
50N	0 to 2x Is - 40 ms, ± 10 ms, 0 to 5x Is - 30 ms, ± 10 ms

Operate time following delay	tbasic + td, ± 1 % or ± 10 ms
Inhibited by	Binary or Virtual Input Inrush detector
Disengaging time (50G)	< 50 ms

51 Time Delayed OC&EF

Operation	Non directional
Elements	Phase, Derived Earth, Measured Earth
Characteristic	IEC-NI, -VI, -EI, -LTI; ANSI-MI, -VI, -EI; DTL
Setting Range Is (51/51N)	0.05, 0.06... 4 x In
Setting Range Is (51G)	0.01, 0.011, ..., 0.5 x In
Time Multiplier	0.01, 0.015... 1.6, 1.7, ..., 5, 6... 100
Time Delay	0, 0.01... 20 s
Operate Level	105 % Is, ± 4 % or ± 1 % x In
Minimum Operate time IEC	$t_{op} = \frac{K}{\left[\frac{I}{I_s}\right]^\alpha - 1} \times Tm$
ANSI	$t_{op} = \left[\frac{A}{\left[\frac{I}{I_s}\right]^p - 1} + B \right] \times Tm$ ± 5 % absolute or ± 40 ms for TMS setting (0.01 to 0.245) ± 5 % absolute or ± 30 ms for TMS setting (0.25 to 100)
Follower Delay	0 s - 20 s
Reset	ANSI decaying, 0 s - 60 s
Inhibited by	Binary or Virtual Input Inrush detector

50 BF Circuit Breaker Fail

Operation	Current check - Phase and Measured Earth with independent settings Mechanical Trip CB Faulty Monitor
Setting Range Is	0.05, 0.055... 2.0 x In
Setting Range Is	0.01, 0.015, ..., 2.0 x In
2 Stage Time Delays	Timer 1 20... 60000 ms Timer 2 20... 60000 ms
Operate Level	100 % Is, ± 5 % or ± 1 % x In
Disengaging time	< 20 ms
Operate time following delay	Tcbf ± 1 % or ± 20 ms
Triggered by	Any function mapped as trip contact
Inhibited by	Binary/Virtual Input
Timer By pass	Yes, 50BF CB Faulty Input

74 T/CCS Trip/Close Circuit Supervision

Number of supervisable circuits	3 x Trip and 3 x Close
Number of BI's Required	1 or 2 per function

50BCL Break Capacity Limit

Setting	1.0, 1.5... 50 x In
Operate level	100 % Is, ± 5 % or ± 1 % In
Reset level	≥ 95 % Iop
Element basic operate time	0 to 2 x Is: 20 ms or ± 10 ms 0 to 5 x Is: 15 ms or ± 10 ms

46PH REV Phase Reversal

NPS to PPS ratio	20...100 %
Delay setting	0...14400 s
Operate level	100 % I _s ± 5 %
Reset level	>85 % I _{op} ,
Basic operate time	1x I _n to 0 A 60 ms
Operate time	t _f + t _{basic} , ±1 % or ± 20 ms

Temperature Inputs (RTD)

Temperature input type (Temperature Coefficient Resistance based on DIN/IEC 60751 standard)	Cu10 (0.00427), Ni100 (0.00618), Pt100 (0.00385), Ni120 (0.00672), Pt250 (0.00385), Ni250 (0.00618), and Pt1000 (0.00385)
Temperature input Alarm	0,1,2...250°C
Temperature input Trip	0,1,2...250°C
Operate value	100 % T _{set} , ± 2% or ±2°C, For Cu10: ± 2 % or ± 5°C
Response time	< 3 s
Sensing current	≤ 0.5 mA
Maximum lead resistance	25 Ω/lead For Cu10: 2.5 Ω/lead

Control Functions

Motor	Start/Stop
EF	IN/OUT
Relay Mode	Local/Remote/Local or Remote
Reset	LED's & O/P's (Test/Reset key)

CB Maintenance

Trip Counter	Total & Delta 0...10000
I ² t Alarm	10...100000

Case Dimensions

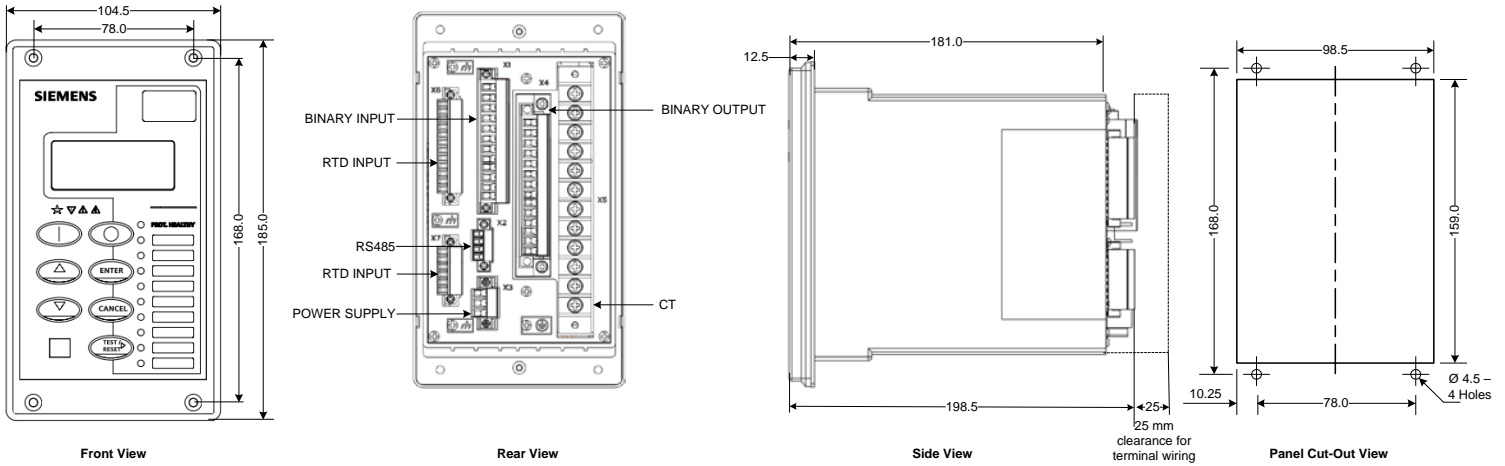

7SR105 Terminal/Wiring Diagram

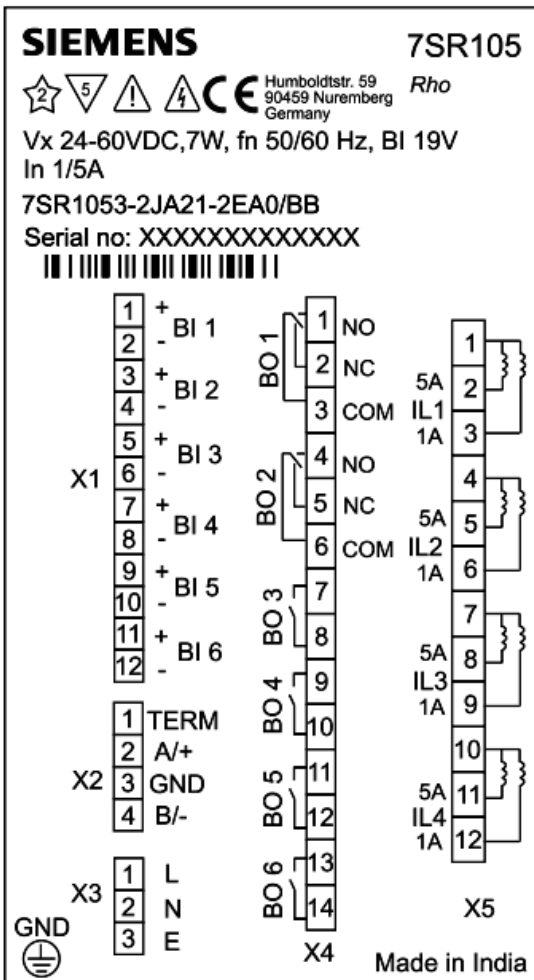

Fig 8. Terminal/Wiring Diagram View (Non RTD)

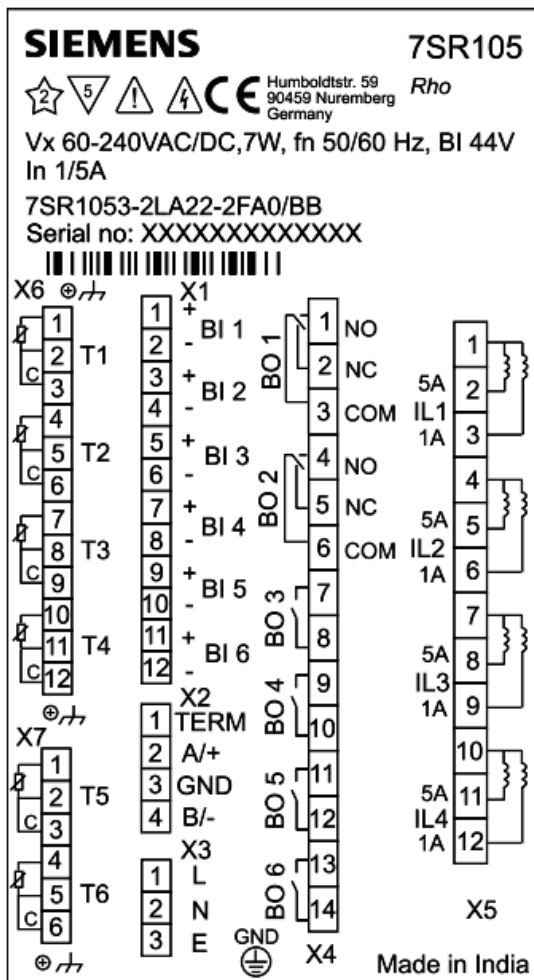

Fig 9. Terminal/Wiring Diagram View (RTD)

Siemens Protection Devices Limited
P.O. Box 8
North Farm Road
Hebburn
Tyne & Wear
NE31 1TZ
United Kingdom
Phone: +44 (0)191 401 7901
Fax: +44 (0)191 401 5575
E-mail: marketing.spdl.qb@siemens.com

EMDG-C10036-00-76GB

For enquiries, please contact our Customer Support Centre

Phone: +49 180/524 8437 (24hrs)
Fax: +49 180/524 24 71
E-mail: support.energy@siemens.com

www.siemens.com/reyrolle